

# FCL Components Touch Panels

## *The Technology*

### *4-Wire Panels - How They Work*

#### Construction Details

A resistive touch panel is made by sandwiching together ITO (Indium Tin Oxide) coated glass and PET (Poly Ethylene Terephthalate). The process is illustrated by pictures 1 through 5, opposite. The glass is for mechanical stability and the PET provides the flexible medium through which the two parts connect.

Microdot spacers separate the layers to avoid accidental input. The microdot spacers are printed onto the glass by a proprietary process, which allows precise control over dot size, height and density. Dot density determines the operation method from low density finger to higher density pen-operation panels.

A slight positive air pressure in between the layers and a sealed construction prevents dirt and dust from entering the panel. Basic operation is shown in the exaggerated cross section below.

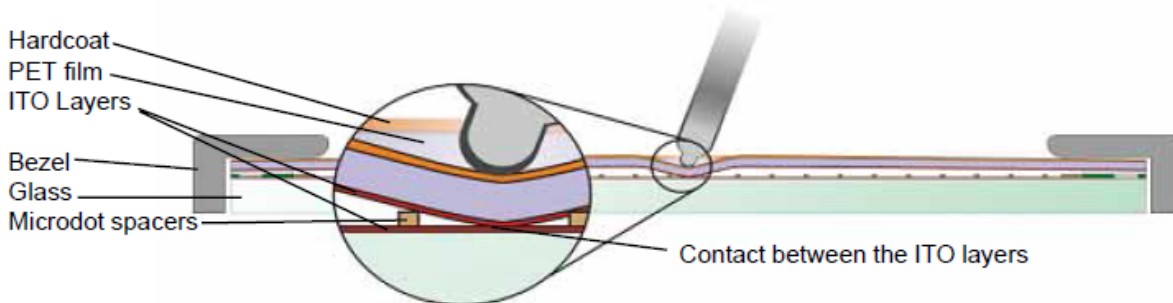
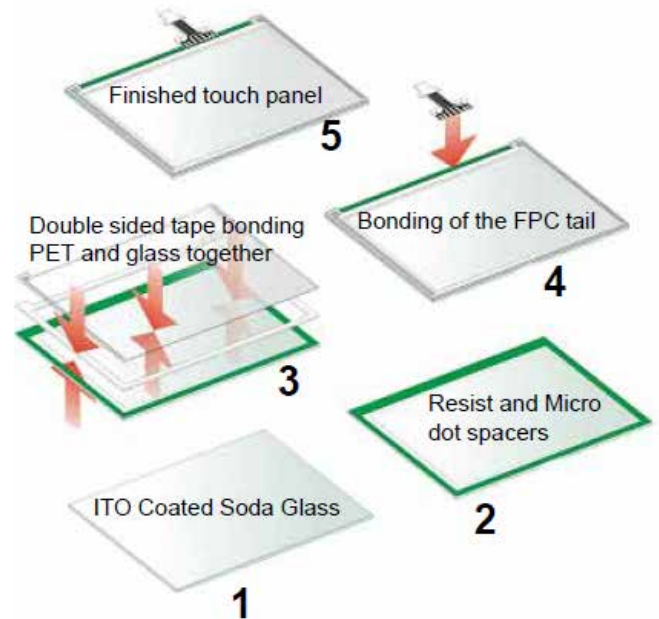

At the same time as the microdot spacers are created, an edge-life enhancement pattern is placed along the sides. This allows the panel to withstand more edge slide operations as the PET layer is cushioned when under stress from operation by a pen.

Point (B) prevents the angle of the film at point (A) from being too sharp against the sealing tape. Flexing of this point weakens the PET ITO and causes premature reliability issues on alternative lower quality designs.

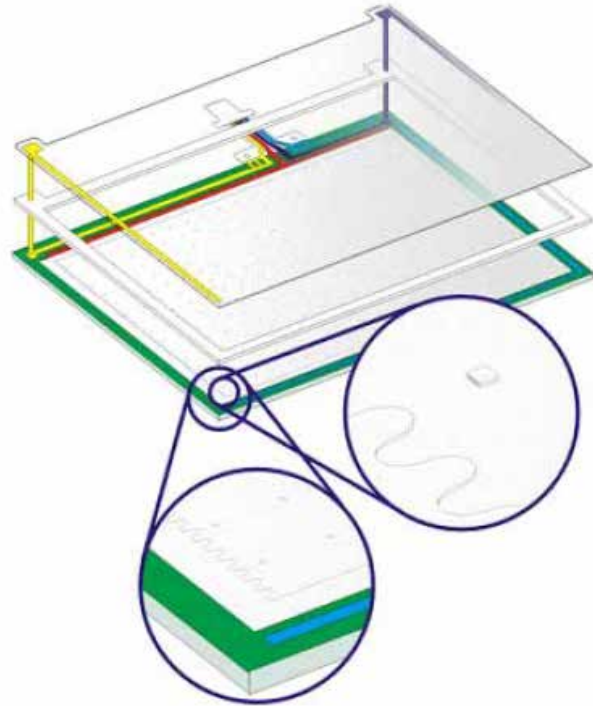
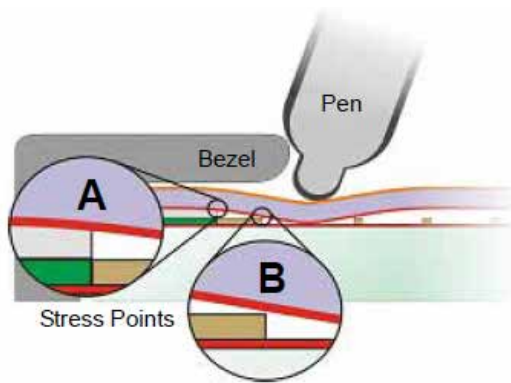

### How 4-wire panels work – in simple terms

The above diagrams show how one ITO plane on the glass can be used to measure the voltage and find the point of touch in one direction. The ITO plane on the PET is used to measure the voltage and find the point of touch in a perpendicular direction. The Serial or USB decoder chip will then tell the system where the panel has been touched by measuring the voltages in each plane.

FCL Components uses the best materials possible for optimal panel quality, but, regardless of this, the PET will eventually weaken over time and ITO degradation will occur, changing the resistance slightly. To counteract both these issues, FCL Components developed the 7-wire panel, which provides 10x the reliability of the 4-wire while retaining all the design features of the 4-wire mentioned here.

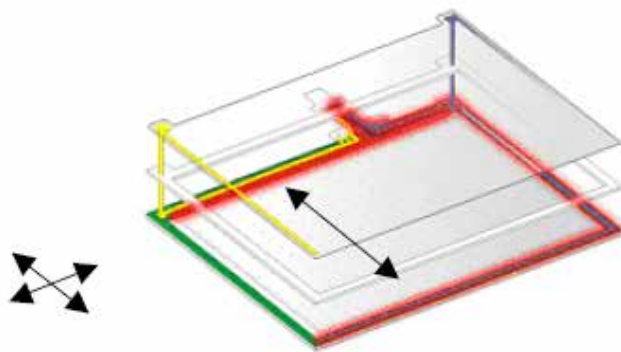

**Y measurements – Glass-based ITO circuit**

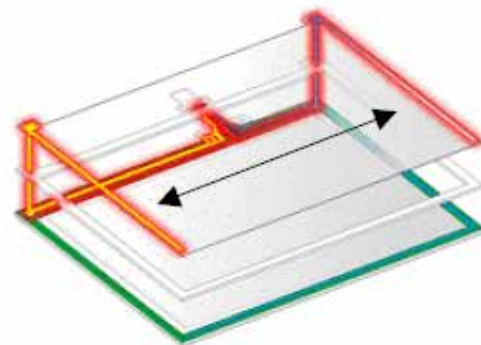

**X measurements – PET-based ITO circuit**

## Transparent Film with Conductive Polymer

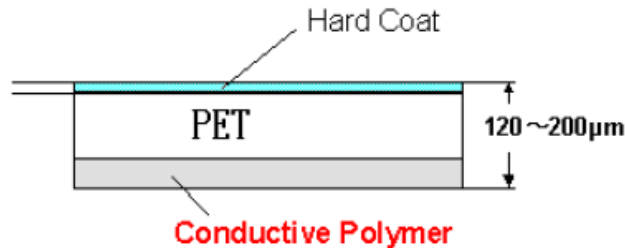

Able to withstand 200,000 pen inputs with no significant degradation or resistance changes, the new touch panels are more durable than those using ITO film. They are also less costly and more ecologically friendly to produce than ITO-film touch panels. Applications include cell phones, PDAs, tablet PCs, and other pen-based devices where longer life and higher reliability are required.

To produce the conductive polymer touch panels in sizes ranging from 2.9 to 17 inches, FCL Components is developing a film coating process that is cost efficient and ecologically friendly. Using a roll coater, the liquid conductive polymer is combined with a water-based solvent and is applied to the PET film with very uniform thickness. This coating process eliminates the need for sputtered film and reduces production costs in high volume compared to ITO-film touch panels.

The new touch panels have similar conductivity and transparency properties as ITO-film touch panels. Using a patented, molecular-orientation technology, FCL Components is able to produce the conductive polymer material with 93 percent transparency over the 400-700 nanometer spectrum.

---

### Contact

#### Japan

FCL COMPONENTS LIMITED  
Shinagawa Seaside Park Tower  
12-4, Higashi-shinagawa 4-chome,  
Tokyo 140 0002, Japan  
Tel: +81 3 3450 1682  
Email: fcl-contact@cs.fcl-components.com

#### Europe

FCL COMPONENTS EUROPE B.V.  
Diamantlaan 25  
2132 WV Hoofddorp  
Netherlands  
Tel: +31 23 5560910  
Email: info@fcl-components.eu

#### China

FCL COMPONENTS (SHANGHAI) CO., LTD.  
Unit 1105, Central Park –Jing An, No.329 Heng  
Feng Road, Shanghai 200070, China  
Tel: +86 021 3253 0998  
Email: fcsh@fcl-components.com

#### North and South America

FCL COMPONENTS AMERICA, INC.  
2055 Gateway Place, Suite 480  
San Jose, CA 95110 U.S.A.  
Tel: +1 408 745 4900  
Email: fcai.components@fcl-components.com

#### Asia Pacific

FCL COMPONENTS ASIA, LTD.  
No. 20 Harbour Drive, #07-01B  
Singapore 117612  
Tel: +65 6375 8560  
Email: fcal@fcl-components.com

#### Hong Kong

FCL COMPONENTS HONG KONG CO., LIMITED  
Room 13, 23/F, Seapower Tower, Concordia Plaza,  
No.1 Science Museum Road,  
Tsim Sha Tsui East, Kowloon, Hong Kong  
Tel: +852 2881 8495  
Email: fcsh@fcl-components.com

**Web:** [www.fcl-components.com/en/](http://www.fcl-components.com/en/)

---

### Copyright

All trademarks or registered trademarks are the property of their respective owners. FCL Components America or its affiliates do not warrant that the content of datasheet is error free. In a continuing effort to improve our products FCL Components America, Inc. or its affiliates reserve the right to change specifications/datasheets without prior notice.

Copyright ©2024 FCL Components America, Inc. All rights reserved. Revised February 1, 2024.