

Discontinued in September 2025

FCL Components Touch Panels

Standard and Light Touch 4-Wire series

FCL Components Resistive Touch Panel Specification

Features

- Superior quality 4-wire resistive touch panel
- Available in standard or light input force types (min. 0.02N)
- Light input type panels with dual input gesture support are comparable to PCAP panels
 - Pinch, Zoom, Rotate, Swipe or Flick action detection by the controller
- Excellent specification and high quality
 - Anti Newton ring technology
 - High reliability materials
- Pen/finger input type
- Transparency 80~90%
- Flush surface, logo and custom colored rim area
- Optional AS, AG coating, antibacterial finish, enhanced writing friction finish available
- RoHS compliant



■ Standard 4-Wire Resistive Touch Panel Part Numbers

Size	Aspect Ratio	Part number	Transparent area (mm)	Glass thickness (mm)	Tail (Flex) length mm	Transparency %
15.0	4x3	N010-0554-T902A	309.2 x 234.23	1.1	61	80
12.1	4x3	N010-0554-T805A	250.9 x 190.8	1.1	75	82
12.1	4x3	N010-0554-T814A <i>(Discontinued 2024)</i>	250.9 x 190.8	1.1	120	82
10.4	4x3	N010-0554-T303A	216.2 x 164.6	1.1	75	80
10.4	4x3	N010-0554-T347A	216.2 x 164.6	1.1	75	82.5
10.4	4x3	N010-0554-T352A	216.2 x 164.6	1.1	120	82.5
8.4	4x3	N010-0554-T504A	173.8 x 131.8	0.7	75	80
6.5	4x3	N010-0554-T043A (AG)	133.6 x 102.7	1.1	61	82
6.5	4x3	N010-0554-T048A	133.6 x 102.7	1.1	120	86
5.7	4x3	N010-0554-T009A	122.0 x 93.9	1.1	46.2	80
3.8	4x3	N010-0554-T703A (AG)	61.6 x 82.5	0.7	21	80

■ Light Touch 4-Wire Resistive Touch Panel Part Numbers

Size	Aspect Ratio	Part number	Transparent area (mm)	Glass thickness (mm)	Tail (Flex) length mm	Transparency %
22	wide	FID-1111-501-A22	479.76 x 303.1	1.8	120	80
19	4x3	FID-1111-381-A19	382.9 x 307.7	1.8	120	80
17.1	4x3	NC01111-T281	342.3 x 274.1	1.8	61	80
15.3	wide	NC01152-T021	338.08 x 204.44	1.1	61	80
15	4x3	NC01111-T261	309.2 x 234.23	1.1	61	80
12.1	wide	NC01111-T081	264.12 x 167.2	1.1	120	80
12.1	4x3	NC01111-T241 (AS) <i>(Discontinued 2024)</i>	250.9 x 190.8	1.1	61	80
12.1	4x3	NC01111-T242	250.9 x 190.8	1.1	75	80
10.4	4x3	NC01111-T221 <i>(Discontinued 2024)</i>	216.2 x 164.6	1.1	61	80
10.4	4x3	NC01111-T222	216.2 x 164.6	1.1	75	80
10.1	wide	FID-1154-401-A10	223.4 x 141.5	1.1	50	80
8.4	4x3	NC01111-T202	173.8 x 131.8	1.1	75	80
8	wide	NC01101-T081	180.8 x 103.8	1.1	50	82
7	wide	NC01152-T101	157.4 x 95.0	1.1	50	82
4.3	4x3	NC01111-T181	99.1 x 57.5	1.1	50	80
3.8	4x3	NC01111-T161	61.6 x 82.5	0.7	21	80

■ Notes

- AS = Anti-Smudge
- Full specifications are available - please contact your local Sales Representative or use the Contact Form to request

■ Controller Boards

Part Number	Type
NC01850-B070RS	4-wire, RS232
NC01850-B010RS	4-wire, USB
FID-1850-120	4-wire, USB, dual touch*

*: Dual touch does not work with Windows[™] 10 version 1809 or later.

■ Interface Controller Chips

Part Number	Type
NC41120-0036	4-wire, RS232
NC41120-0051	4-wire, USB
FID-1860-002	4-wire, RS232, dual touch
FID-1860-005	4-wire, USB, dual touch*

*: Dual touch does not work with Windows[™] 10 version 1809 or later.

■ Dimension example (10.4" shown)

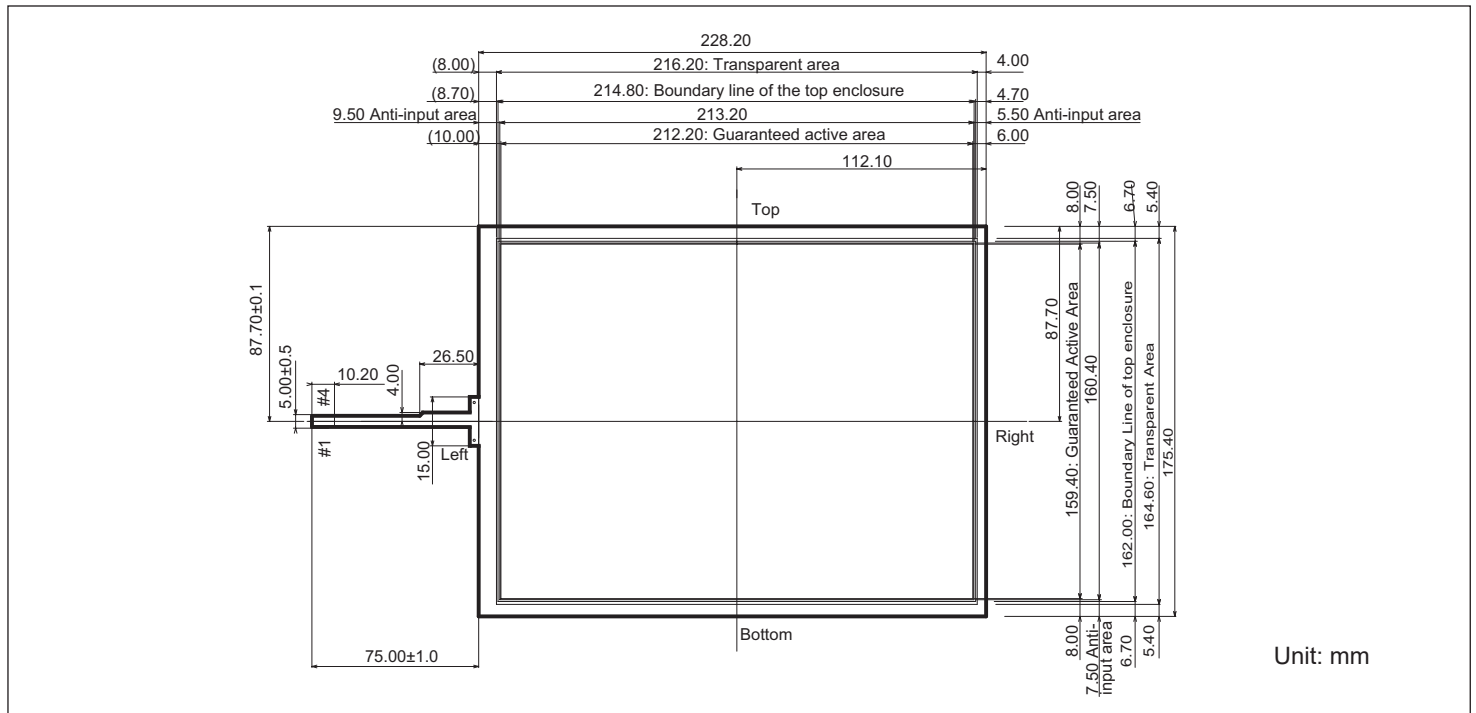

■ System description and block diagram

This panel in combination with a control IC chip or control board is used to transfer the co-ordinate data to the host system. Please see block diagram.

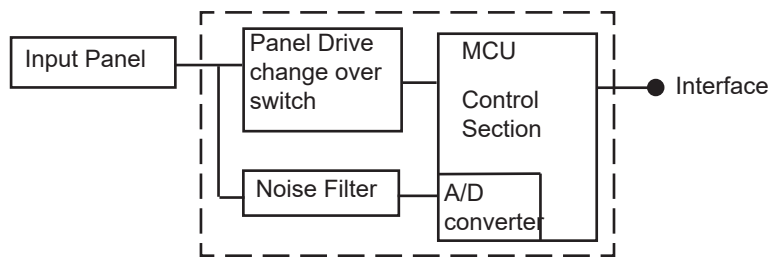

■ General notes

Touch panels are made of glass, so care must be taken in handling them. Do not stress, pile, bend, lift by the cable or put any stress on the film, for example moving by film face vacuum. In order to clean wring dry a cloth which has been emersed in a natural detergent. DO NOT use any organic solvent, acid or alkali solution. Watch the edge of the panel when cleaning, again for safety reasons.

■ Detailed specifications

This specification applies to the standard series Resistive Touch Panel (Pen/Finger type)
Complete specification document is available upon request.

■ Electrical

	Standard 4-wire	Light Touch 4-wire
Rated voltage	DC 5V (DC 7V maximum)	DC 5V (DC 7V maximum)
Switch bounce (chattering)	20ms maximum	20ms maximum
Insulation resistance	10MΩ minimum	10MΩ minimum

■ Environmental

	Standard 4-wire	Light Touch 4-wire
Operating temperature	-5°C to 60°C	-5°C to 60°C
Storage temperature	-30°C to 70°C	-30°C to 70°C
Operating humidity *1	20% to 85%	20% to 90%
Storage humidity *1	10% to 90% RH	10% to 90% RH

*1: Maximum wet bulb temperature of 38°C

Contact

<p>Japan FCL COMPONENTS LIMITED Shinagawa Seaside Park Tower 12-4, Higashi-shinagawa 4-chome, Tokyo 140 0002, Japan Tel: +81 3 3450 1682 Email: fcl-contact@cs.fcl-components.com</p>	<p>Europe FCL COMPONENTS EUROPE B.V. Diamantlaan 25 2132 WV Hoofddorp Netherlands Tel: +31 23 5560910 Email: info@fcl-components.eu</p>	<p>China FCL CCOMPONENTS (SHANGHAI) CO., LTD. Unit 1105, Central Park –Jing An, No.329 Heng Feng Road, Shanghai 200070, China Tel: +86 021 3253 0998 Email: fcsh@fcl-components.com</p>
<p>North and South America FCL COMPONENTS AMERICA, INC. 2055 Gateway Place, Suite 480 San Jose, CA 95110 U.S.A. Tel: +1 408 745 4900 Email: contact@fcl-components.us</p>	<p>Asia Pacific FCL COMPONENTS ASIA, LTD. 51 Changi Business Park Central, #06-07 Singapore 486066 Tel: +65 6375 8560 Email: fcal@fcl-components.com</p>	<p>Hong Kong FCL CCOMPONENTS HONG KONG Co., LIMITED Room 13, 23/F, Seapower Tower, Concordia Plaza, No.1 Science Museum Road, Tsim Sha Tsui East, Kowloon, Hong Kong Tel: +852 2881 8495 Email: fcsh@fcl-components.com</p>

Web: www.fcl-components.com/en/

Copyright

All trademarks or registered trademarks are the property of their respective owners. FCL Components America or its affiliates do not warrant that the content of datasheet is error free. In a continuing effort to improve our products FCL Components America, Inc. or its affiliates reserve the right to change specifications/datasheets without prior notice.

Copyright ©2025 FCL Components America, Inc. All rights reserved. Revised September 25, 2025.