

FCL Components Thermal Printer FTP-63GMCL463#10-R

FCL Components 3" high speed (up to 250mm/s) thermal printer mechanism with cutter

Overview

The FTP-63GMCL series thermal printer driven by 24VDC provides high speed printing (up to 250mm/s) for 3-inch wide paper.

The series is suitable for a variety of applications, such as POS/ECR, kiosk terminals, ticket machines, label printers, banking machines, measuring devices, medical equipment, etc.

Features

- High-speed printing
It can print up to 250mm/s (2,000 dotlines/s) maximum by using FCL Components' unique head drive control
- Rear paper insertion mechanism with lock type
FCL Components' unique platen release mechanism allows for a straight paper path and easy head maintenance
- Auto Cutter
Ultra-low profile auto cutter (full/partial cut) mounted at the factory
- Multi-featuring diecast frame
The rugged die-cast frame provides excellent ESD performance, is shock/vibration resistant and the heat-sink allows for continuous printing
- Compact size
Width: 100.5mm, depth: 32.6mm, height: 45.6mm
- High resolution
8 dots/mm head provides clear print
- Paper width
80mm
- RoHS compliant
- UL recognized. File number E171434

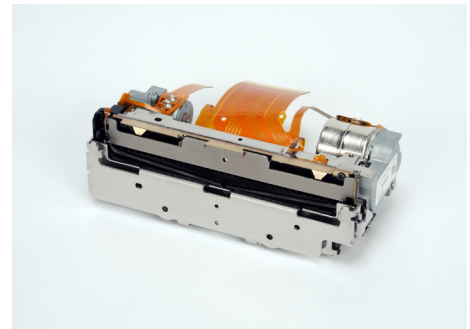

FTP-63GMCL463#10-R

■ Part numbers

Item		Part Numbers
Mechanism	With cutter, rear insertion	FTP-63GMCL463 #10-R
LSI for driving		FTP-62GCU211-R
Interface board	USB/RS232C	FTP-62GDSL211-R
Interface cable	Serial	FTP-62GY302-R
	USB	FTP-62GY311#01-R
Power supply cable	Logic, head, motor	FTP-629Y603-R

■ Specifications

Item	Specifications	
Part number	FTP-63GMCL463#10-R	
Printing method	Thermal sensitive line dot method	
Dot structure	576 dots/lines	
Dot pitch (horizontal)	0.125mm (8 dots/mm) - Dot density	
Dot pitch (vertical)	0.125mm (8 dots/mm) - Line feed pitch	
Effective printing area	72mm	
Number of columns	ANK 48 columns/line (12 x 24 x dot font), OCD 24 columns (24 x 40)	
Paper width	80mm +0/-1	
Paper thickness	60-100 μ m*1	
Cutting type	Full or partial	
Printing speed	250mm/s (2,000 dot lines/s)	
Character types	Alphanumeric KANA	159 types
	International and special	195 types
	OCR I	103 types
	OCR III	23 types
	OCR IV	103 types
	Extended numeric	12 types
	JIS KANJI level 1, 2, non-Kanji	JIS KANJI: approx. 6800 (FTP-62GDSL111#01) 13, 503 (FTP-62GDSL111#02)
	Traditional Chinese	
Character dimensions (W x H), number of characters	8 x 16 dots, 72 columns, ANK	24 x 40 dots, 24 columns, OCR I
	12 x 24 dots, 48 columns, ANK	24 x 48 dots, 24 columns, OCR II
	16 x 16 dots, 36 columns, ANK	36 x 60 dots, 16 columns, OCR IV
	24 x 24 dots, 24 columns, ANK	24 x 48 dots, 24 columns, extended numeric

*1: There may be exceptions

Item	Specifications	
Part number	FTP-63GMCL463 #10-R	
Power	For head	24VDC \pm 10% 4.1A (24V, 800 Ω , concurrent applied dot number: 144 dots)
	For printer motor	24VDC \pm 10% 1.5A maximum
	For logic	3.3 or 5 VDC \pm 5% 75mA maximum
Dimensions (WxDxH)	Printer mechanism	100.5 x 32.6 x 45.6mm
	Interface board	70 x 37mm
Weight	Printer mechanism	155g
	Interface board	15g
Expected life	Head	Pulse durability: 100 million pulse/dot (using FCL Components' standard driving method) Wear resistance: 100km (at 12.5% print ratio)
	Cutter	1,000,000 cuts min.*2
Environmental conditions	Operating temperature	+5°C to +40°C (guarantee)
	Operating humidity	20 to 85% RH (no condensation)
	Storage temperature	-20°C to +60°C (excluding paper)
	Storage humidity	5 to 95% RH (no condensation)
Detection functions	Head temperature	By thermistor
	Paper out/Mark detect	By photointerrupter
	Head release	By slide switch
Recommended thermal sensitive paper	High sensitive paper	TF50KS-E45 (Nippon paper)
	Standard paper	TP-60KS-E (Nippon paper)
		PD150R (Oji paper)
	Medium term paper	TP-60KS-F1 (Nippon paper)
P220VBB-1 (Mitsubishi paper)		
Long term paper	PD160R (Oji paper)	
	TP50KJ-R (Nippon paper)	

*2: Under conditions of 20 \pm 5°C, 40 to 60% RH, cut cycle min. 3 sec., max. 20 cut per min.

■ Dimensions

- Printer mechanism with cutter 3-inch

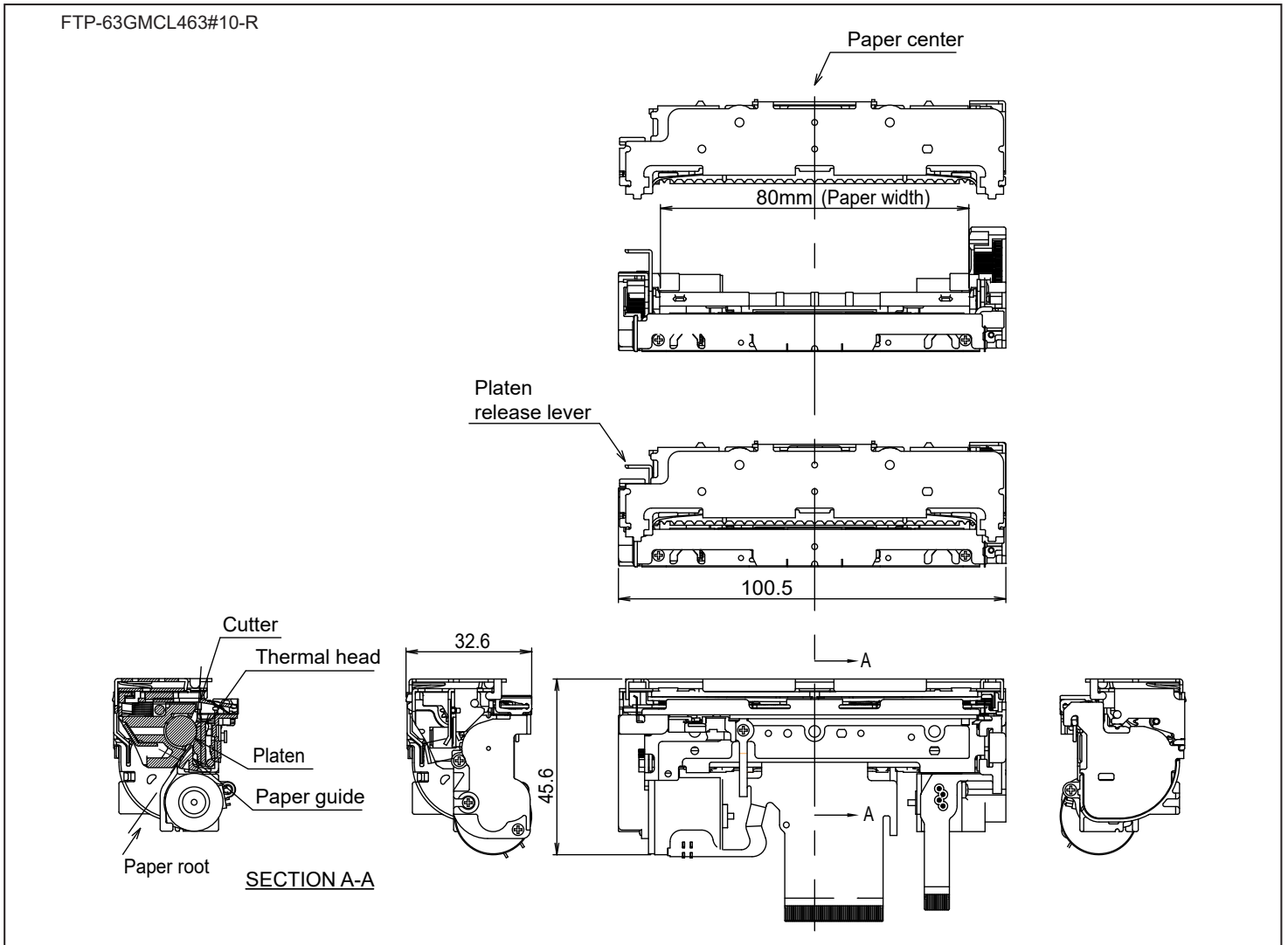

Note: 1. Dimensions are nominal value)tolerance $\pm 0.5\text{mm}$ unless otherwise specified.
2. Dimensions in () is reference value.

■ Connector pin assignments of cutter (FPC) 54104-5031 (Molex or equivalent)

Recommended connector for head FPC: 54104-5031 (Molex) or equivalent

No	Signal	Content	I/O
1	VSEN	Paper sensor power	IN
2	PHK	Cathode for photo interrupter	OUT
3	PHE	Emitter for photo interrupter	OUT
4	N.C.	Not connected	-
5	VH	Head drive power	IN
6	VH	Head drive power	IN
7	VH	Head drive power	IN
8	VH	Head drive power	IN
9	VH	Head drive power	IN
10	VH	Head drive power	IN
11	DI	Data in	IN
12	/STB3	/Strobe3	IN
13	N.C.	Not connected	-
14	VDD	Logic power	IN
15	GND	Head ground	-
16	GND	Head ground	-
17	GND	Head ground	-
18	GND	Head ground	-
19	GND	Head ground	-
20	GND	Head ground	-
21	GND	Head ground	-
22	GND	Head ground	-
23	GND	Head ground	-
24	GND	Head ground	-
25	GND	Head ground	-
26	GND	Head ground	-
27	TM	Thermistor	OUT
28	/STB1	/Strobe1	IN
29	/STB2	/Strobe2	IN
30	/LAT	/Data latch	IN
31	CLK	Clock	IN
32	VH	Head drive power	IN
33	VH	Head drive power	IN
34	VH	Head drive power	IN
35	VH	Head drive power	IN
36	VH	Head drive power	IN
37	VH	Head drive power	IN
38	N.C.	Not connected	-
39	SW	Platen switch release	OUT
40	SW	Platen switch release	OUT
41	MTM	Motor thermistor	OUT
42	MTM	Motor thermistor	OUT

No	Signal	Content	I/O
43	MT_/A	Excitation signal /A	SINK/SOURCE
44	MT_/A	Excitation signal /A	SINK/SOURCE
45	MT_A	Excitation signal A	SINK/SOURCE
46	MT_A	Excitation signal A	SINK/SOURCE
47	MT_/B	Excitation signal /B	SINK/SOURCE
48	MT_/B	Excitation signal /B	SINK/SOURCE
49	MT_B	Excitation signal B	SINK/SOURCE
50	MT_B	Excitation signal B	SINK/SOURCE

- Connector pin assignments of printer mechanism (FPC) - for FTP-63GMCL463#10-R only
Recommended connector for cutter FPC : 52745-1297 (Molex) or equivalent

No	Signal	Content	I/O
1	MT_B	Excitation signal B	SINK/SOURCE
2	MT_B	Excitation signal B	SINK/SOURCE
3	MT_/B	Excitation signal /B	SINK/SOURCE
4	MT_/B	Excitation signal /B	SINK/SOURCE
5	MT_A	Excitation signal A	SINK/SOURCE
6	MT_A	Excitation signal A	SINK/SOURCE
7	MT_/A	Excitation signal /A	SINK/SOURCE
8	MT_/A	Excitation signal /A	SINK/SOURCE
9	N.C.	Not connected	-
10	VSEN	Paper sensor power	IN
11	PHE	Emitter for photo interrupter	OUT
12	PHK	Cathode for photo interrupter	OUT

Contact

Japan

FCL COMPONENTS LIMITED
Shinagawa Seaside Park Tower
12-4, Higashi-shinagawa 4-chome,
Tokyo 140 0002, Japan
Tel: +81 3 3450 1682
Email: fcl-contact@cs.fcl-components.com

Europe

FCL COMPONENTS EUROPE B.V.
Diamantlaan 25
2132 WV Hoofddorp
Netherlands
Tel: +31 23 5560910
Email: info@fcl-components.eu

China

FCL COMPONENTS (SHANGHAI) CO., LTD.
Unit 1105, Central Park –Jing An, No.329 Heng Feng
Road, Shanghai 200070, China
Tel: +86 021 3253 0998
Email: fcsh@fcl-components.com

North and South America

FCL COMPONENTS AMERICA, INC.
2055 Gateway Place, Suite 480
San Jose, CA 95110 U.S.A.
Tel: +1 408 745 4900
Email: contact@fcl-components.us

Asia Pacific

FCL COMPONENTS ASIA, LTD.
51 Changi Business Park Central, #06-07
Singapore 486066
Tel: +65 6375 8560
Email: fcal@fcl-components.com

Hong Kong

FCL COMPONENTS HONG KONG Co., LIMITED
Room 13, 23/F, Seapower Tower, Concordia Plaza,
No.1 Science Museum Road,
Tsim Sha Tsui East, Kowloon, Hong Kong
Tel: +852 2881 8495
Email: fcsh@fcl-components.com

Web: www.fcl-components.com/en/

Copyright

All trademarks or registered trademarks are the property of their respective owners. FCL Components America or its affiliates do not warrant that the content of datasheet is error free. In a continuing effort to improve our products FCL Components America, Inc. or its affiliates reserve the right to change specifications/datasheets without prior notice.

Copyright ©2026 FCL Components America, Inc. All rights reserved. Revised February 19, 2026.