

DISCONTINUED March 2023

# FUJITSU Component Thermal Printer FTP-63GMCL153/453 series

Fujitsu 3" high speed (up to 200mm/s) thermal printer mechanism with cutter option

## Overview

The FTP-63GMCL series thermal printer driven by 24VDC provides high speed printing (up to 200mm/s) for 3-inch wide paper.

The series is suitable for a variety of applications, such as POS/ECR, kiosk terminals, ticket machines, label printers, banking machines, measuring devices, medical equipment, etc.

## Features

- **High-speed printing**  
It can print up to 200mm/s (1600 dotlines/s) maximum by using Fujitsu Components' unique head drive control
- **Rear paper insertion mechanism with lock type**  
Fujitsu Components' unique platen release mechanism allows for a straight paper path and easy head maintenance
- **Auto Cutter**  
Optional ultra-low profile auto cutter (full/partial cut) comes mounted from the factory.
- **Multi-feature diecast frame**  
The rugged die-cast frame provides excellent ESD performance, is shock/vibration resistant and the heat-sink allows for continuous printing
- **Compact size**  
Depth: 20.4mm, width: 96.2mm, height: 36.3mm (FTP-63GMCL153)  
Depth: 32.4mm, width: 100.5mm, height: 45.6mm (FTP-63GMCL453)
- **High resolution**  
8 dots/mm head provides clear print
- **Paper width**  
80mm
- **RoHS compliant**
- **UL recognized. File number E171434**



FTP-63GMCL153



FTP-63GMCL453

## ■ Part numbers

Item		Part Numbers
Printer mechanism	Back insertion	FTP-63GMCL153
Mechanism with cutter	Rear insertion	FTP-63GMCL453
LSI for driving		Under development
Interface board	Serial (RS232C/USB)	FTP-62GDSL001#01 (Japanese font)
	Serial (RS232C/USB)	FTP-62GDSL001#02 (Traditional Chinese font)
Interface cable	Serial	FTP-62GY302
	USB	FTP-62GY301
Power supply cable	Logic, head, motor	FTP-62GY601

## ■ Specifications

Item		Specifications	
Part number		FTP-63GMCL153	FTP-63GMCL453
Printing method		Thermal sensitive line dot method	
Dot structure		576 dots/lines	
Dot pitch (horizontal)		0.125mm (8 dots/mm) - Dot density	
Dot pitch (vertical)		0.125mm (8 dots/mm) - Line feed pitch	
Effective printing area		72mm	
Number of columns		ANK 48 columns/line (12 x 24 x dot font), OCD 24 columns (24 x 40)	
Paper width		80mm +0/-1	
Paper thickness		60-150 $\mu$ m*1	60-100 $\mu$ m*1
Cutting type		---	Full or partial
Printing speed		200mm/s (1600 dot lines/s)	
Character types	Alphanumeric KANA	159 types	
	International and special	195 types	
	OCRI	103 types	
	OCRIII	23 types	
	OCRIV	103 types	
	Extended numeric	12 types	
JIS KANJI level 1, 2, non-Kanji	JIS KANJI: approx. 6800		
Traditional Chinese	13, 503		
Character dimensions (W x H), number of characters		8 x 16 dots, 72 columns, ANK	24 x 40 dots, 24 columns, OCRI
		12 x 24 dots, 48 columns, ANK	24 x 48 dots, 24 columns, OCRII
		16 x 16 dots, 36 columns, ANK	36 x 60 dots, 16 columns, OCRIV
		24 x 24 dots, 24 columns, ANK	24 x 48 dots, 24 columns, extended numeric

\*1: there may be exceptions

Item		Specifications	
Part number		FTP-63GMCL153	FTP-63GMCL453
Power	For head	24VDC ±10% 3A (24V, 1500 Ω, +25°C, concurrent applied dot number: 192 dots)	
	For printer motor	24VDC ±10% 0.6A maximum	
	For logic	3.3 or 5 VDC±5% 0.1A maximum	
Dimensions (WxDxH)	Printer mechanism	96.2 x 20.4 x 36.3mm	---
	Printer mechanism w/ cutter	---	100.5 x 32.6 x 45.6mm
	Interface board (DCL/DSL)	70 x 35mm	
Weight	Printer mechanism	79g	---
	Printer mechanism w/ cutter	---	155g
	Interface board (DCL/DSL)	15g	
Expected life	Head	Pulse durability: 100 million pulse/dot (using Fujitsu Components' standard driving method) Wear resistance: 100km (at 12.5% print ratio)	
	Cutter	---	500,000 cuts min.
Environmental conditions	Operating temperature	+5°C to +40°C (guarantee)	
	Operating humidity	20 to 85% RH (no condensation)	
	Storage temperature	-20°C to +60°C (excluding paper)	
	Storage humidity	5 to 95% RH (no condensation)	
Detection functions	Head temperature	By thermistor	
	Paper out/Mark detect	By photointerrupter	
	Head release	By slide switch	
Recommended thermal sensitive paper	High sensitive paper	TF50KS-E45 (Nippon paper)	
	Standard paper	TF-60KS-E (Nippon paper)	
		PD150R (Oji paper)	
	Medium term paper	TF-60KS-F1 (Nippon paper)	
PD170R (Oji paper) P220VBB-1 (Mitsubishi paper)			
Long term paper	PD160R-N (Oji paper)		

■ Dimensions

- Printer mechanism 3-inch

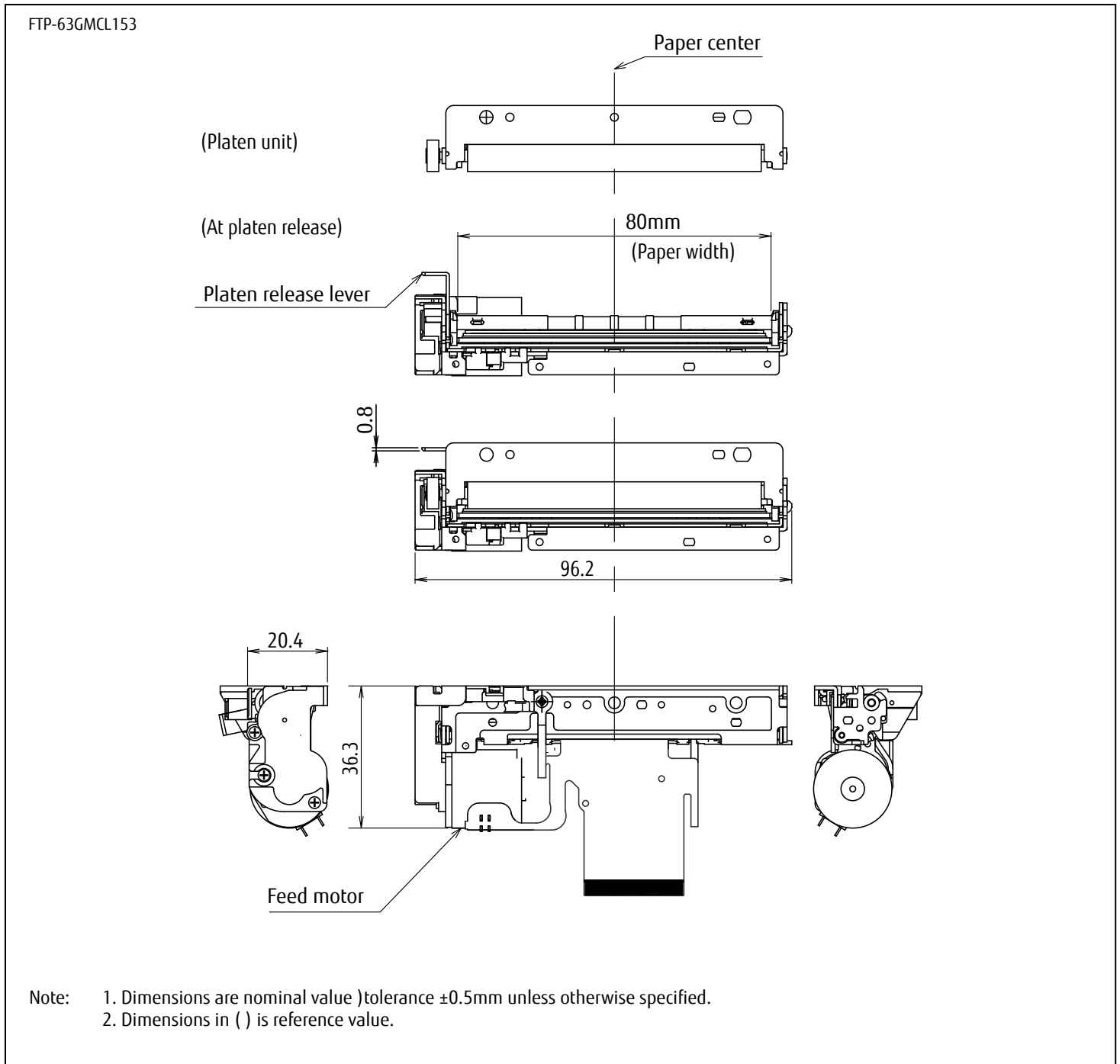

- Printer mechanism / cutter 3-inch

FTP-63GMCL453

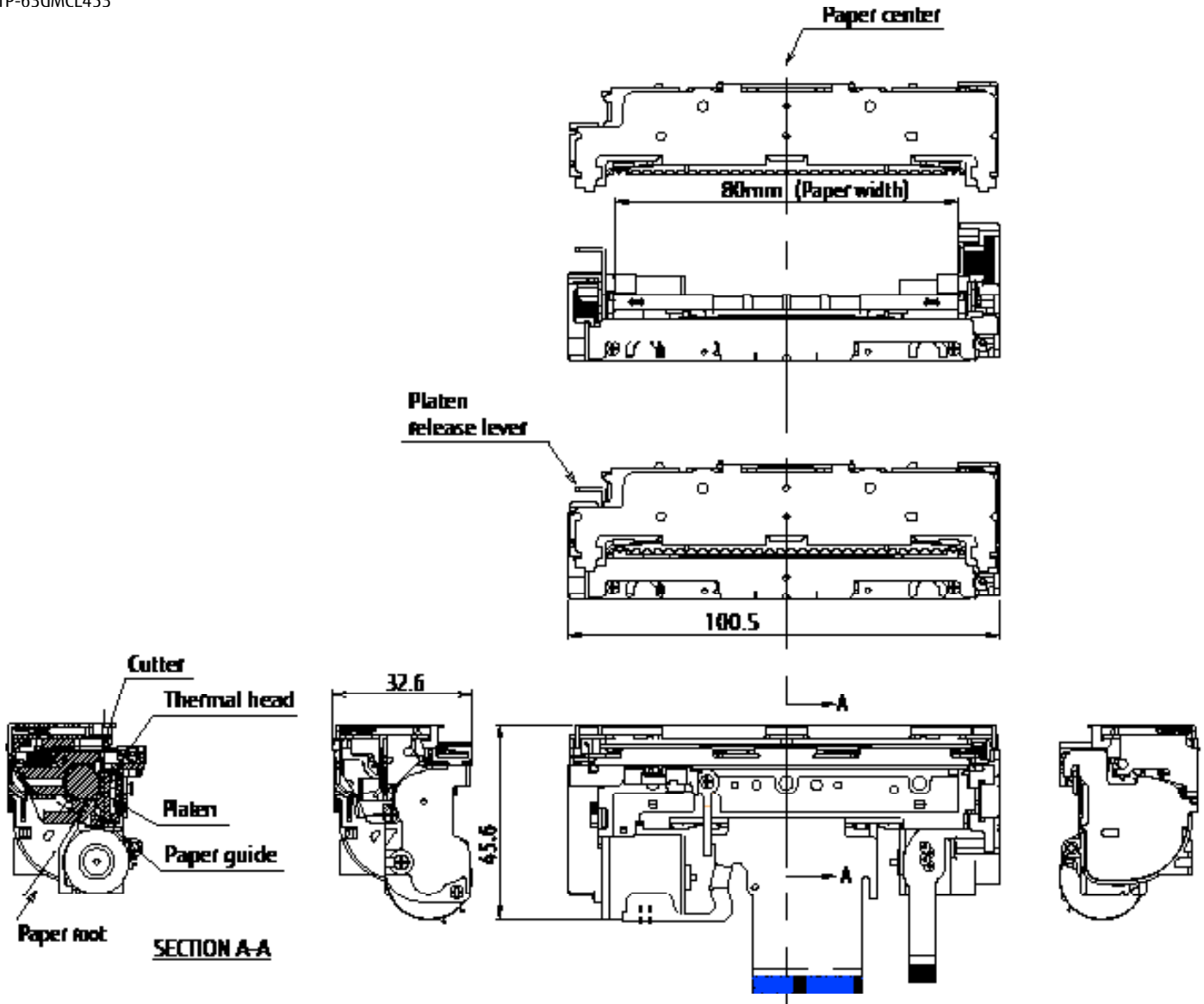

Note: 1. Dimensions are nominal value )tolerance  $\pm 0.5\text{mm}$  unless otherwise specified.  
2. Dimensions in ( ) is reference value.

- Connector pin assignments of printer mechanism (FPC)  
Recommended connector of head FPC: 54104-5031 (Molex ) or equivalent

No	Signal	Content	I/O
1	VSEN	Paper sensor power	IN
2	PHK	Cathode for photo interrupter	OUT
3	PHE	Emitter for photo interrupter	OUT
4	N.C.	Not connected	-
5	VH	Head drive power	IN
6	VH	Head drive power	IN
7	VH	Head drive power	IN
8	VH	Head drive power	IN
9	DI	Data in	IN
10	/STB3	/Strobe3	IN
11	/STB4	/Strobe4	IN
12	VDD	Logic power	IN
13	GND	Head ground	-
14	GND	Head ground	-
15	GND	Head ground	-
16	GND	Head ground	-
17	GND	Head ground	-
18	GND	Head ground	-
19	GND	Head ground	-
20	GND	Head ground	-
21	TM	Thermistor	OUT
22	/STB1	/Strobe1	IN
23	/STB2	/Strobe2	IN
24	/LAT	/Data latch	IN
25	CLK	Clock	IN
26	VH	Head drive power	IN
27	VH	Head drive power	IN
28	VH	Head drive power	IN
29	VH	Head drive power	IN
30	N.C.	Not connected	-
31	SW	Platen switch release	OUT
32	SW	Platen switch release	OUT
33	MT_/A	Excitation signal /A	SINK/SOURCE
34	MT_/A	Excitation signal /A	SINK/SOURCE
35	MT_A	Excitation signal A	SINK/SOURCE
36	MT_A	Excitation signal A	SINK/SOURCE
37	MT_/B	Excitation signal /B	SINK/SOURCE
38	MT_/B	Excitation signal /B	SINK/SOURCE
39	MT_B	Excitation signal B	SINK/SOURCE
40	MT_B	Excitation signal B	SINK/SOURCE

■ Connector pin assignments of cutter (FPC)

Recommended connector of cutter motor FPC: 52745-1297 (Molex) or equivalent

No	Signal	Content	I/O
1	MT_B	Excitation signal B	SINK/SOURCE
2	MT_B	Excitation signal B	SINK/SOURCE
3	MT_/B	Excitation signal /B	SINK/SOURCE
4	MT_/B	Excitation signal /B	SINK/SOURCE
5	MT_A	Excitation signal A	SINK/SOURCE
6	MT_A	Excitation signal A	SINK/SOURCE
7	MT_/A	Excitation signal /A	SINK/SOURCE
8	MT_/A	Excitation signal /A	SINK/SOURCE
9	N.C.	Not connected	-
10	VSEN	Paper sensor power	IN
11	PHE	Emitter for photo interrupter	OUT
12	PHK	Cathode for photo interrupter	OUT

Contact

**Japan**

FUJITSU COMPONENT LIMITED  
Shinagawa Seaside Park Tower  
12-4, Higashi-shinagawa 4-chome,  
Tokyo 140 0002, Japan  
Tel: +81 3 3450 1682  
Email: fcl-contact@cs.fcl-components.com

**Europe**

FUJITSU COMPONENTS EUROPE B.V.  
Diamantlaan 25  
2132 WV Hoofddorp  
Netherlands  
Tel: +31 23 5560910  
Email: info@fcl-components.eu

**China**

FUJITSU ELECTRONIC COMPONENTS  
(SHANGHAI) CO., LTD.  
Room 4306, BM Intercontinental Business Center,  
100 Yutong Rd, Shanghai 200070, China  
Tel: +86 21 3253 0998  
Email: fcsh@fcl-components.com

**North and South America**

FUJITSU COMPONENTS AMERICA, INC.  
350 Cobalt Way, M/s 160  
Sunnyvale, CA 94085 U.S.A.  
Tel: +1 408 745 4900  
Email: fcai.components@fcl-components.com

**Asia Pacific**

FUJITSU COMPONENTS ASIA, Ltd.  
No. 20 Harbour Drive, #07-01B  
Singapore 117612  
Tel: +65 6375 8560  
Email: fcal@fcl-components.com

**Hong Kong**

FUJITSU COMPONENTS HONG KONG Co., Ltd.  
Room 13, 23/F, Seapower Tower, Concordia Plaza,  
No.1 Science Museum Road,  
Tsim Sha Tsui East, Kowloon, Hong Kong  
Tel: +852 2881 8495  
Email: fcsh@fcl-components.com

**Web:** www.fcl.fujitsu.com/en/

Copyright

All trademarks or registered trademarks are the property of their respective owners. Fujitsu Components America or its affiliates do not warrant that the content of datasheet is error free. In a continuing effort to improve our products Fujitsu Components America, Inc. or its affiliates reserve the right to change specifications/datasheets without prior notice.

Copyright ©2023 Fujitsu Components America, Inc. All rights reserved. Revised April 28, 2023.