

FCL Components Thermal Printer

24V DRIVE, FTP-609 SERIES

ULTRA HIGH SPEED (200mm/s)

3" TYPE MECHANISM (with cutter)

FTP-639MCL364#70-R

■ OVERVIEW

The FTP-609MCL Series thermal printer (driven by 24VDC) provides ultra-high speed printing (200mm/s) for 3-inch wide paper.

This series is suitable for a variety of applications, such as POS/ ECR, kiosk terminals, ticket machines, label printers, banking machines, measuring devices, medical equipment, etc.

■ HIGHLIGHTS

- **Ultra high speed printing**
It can print at 200 mm/s (1,600 dotlines/s) maximum by using Fujitsu Components' unique head drive control.
- **ELM (Easy Loading Mechanism) with lock type**
Fujitsu Components' unique platen release mechanism allows easy paper setting and easy head maintenance.
- **Auto Cutter**
Printer with auto cutter (full cut/ partial cut) is available. It can be mounted on top of the mechanism.
- **Multi-featuring diecast frame**
By application of multi-featuring diecast frame, continuous print by function of heat-sink, high ESD stand by function of earth frame and shock/vibration stand by function of solid frame are valid.
- **Compact size**
Depth: 63-70mm, width: 110-113mm, height: 37-38mm.
- **High resolution**
8 dots/mm head provides clear print out.
- **RoHS compliant**



FTP-639MCL364#70-R

■ PART NUMBERS

Name		
Mechanism with cutter	Bottom insertion	FTP-639MCL364#70-R
LSI		FTP-629CU311-R
Interface board	USB, RS232C	FTP-629DSL311-R
Interface cable (board to mechanism)	Serial	FTP-629Y302-R
	USB	FTP-629Y301#01-R
Power supply cable	Logic, head, motor	FTP-629Y603-R

*1: #01 is for full cut, #02 is for partial cut

■ GENERAL SPECIFICATIONS

Item		Specifications
Part number		FTP-639MCL364#70-R
Cutting type		Standard full or partial
Printing method		Thermal sensitive line dot method
Dot structure		640 dots/line
Dot pitch (horizontal)		0.125mm (8dots/mm) - Dot density
Dot pitch (vertical)		0.125mm (8dots/mm) - Line feed pitch
Effective printing area		80 mm
Number of columns		ANK 53 columns/line (12 x 24 dot font) OCR 26 columns (24x40)
Paper width		82.5mm +0/-1
Paper thickness		60 to 100 μ m*1
Printing speed		200mm/sec. (1,600 dot lines/sec.)
Character types	Alphanumeric, Kana: International: JIS Kanji (Kanji CG loaded board): OCRI 103 types OCR II 23 types OCR III 103 types Extended numeric	159 types 195 types about 6,800 types 103 types 23 types 103 types 11 types
Character, dimensions (WxH), number of columns	8x16 dots, 80 columns: ANK 12x24 dots, 53 columns: ANK 16x16 dots, 40 columns: ANK 24x24 dots, 26 columns: ANK	24x40 dots, 26 columns, OCRI 24x48 dots, 26 columns, OCR III 36x60 dots, 17 columns, OCR IV 24x48 dots, 26 columns, extended numeric
Interface standard		RS232C /USB

*1: There may be exceptions

FTP-639MCL364#70

Item	Specifications	
Part number	FTP-639MCL364#70-R	
Power supply	For head	24 VDC \pm 5%, 5.6A (concurrent applied dot: 160 dots)
	For printer motor	24 VDC \pm 5% 1A maximum (2-phase)
	For cutter motor	24 VDC \pm 5% 1A maximum (2-phase)
	For logic	5 VDC \pm 5% 0.1A maximum
Dimension W x D x H	Printer mechanism with cutter	110.4 x 62.5 x 39.4mm
	Interface board	77 x 50 x 21.5mm
Weight	Printer mechanism with cutter	Approximately 320g
	Interface board	Approximately 30g
Life	Head	Pulse durability: 100 million pulse/dot (using Fujitsu's standard driving method) Wear resistance: 100km (at 12.5% print ratio)
	Cutter	500,000 cuts minimum
	Platen	5,000 times (open/close)
Environmental conditions	Operating temperature	+5°C to +40°C (guarantee)
	Operating humidity	20 to 80% RH (no condensation)
	Storage temperature	-20°C to +60°C
	Storage humidity	5 to 90% RH (no condensation)
Detection	Head temperature	By thermistor
	Paper out/Mark detect	By photointerruptor
	Head release	By slide switch
Recommended thermal sensitive paper	High sensitive paper	TF50KS-E4 (Nippon paper)
	Standard paper	TF60KS-E2 (Nippon paper), FTP-030P0104 (80mm) PD150R (Oji paper), FTP-030P0701 (80mm)
	Medium life storage paper	TF60KS-F1 (Nippon paper), FTP-030P0102 (80mm) PD170R (Oji paper) P220VBB-1 (Mitsubishi paper) PD160R-N (Oji paper)
	Long life storage paper	AFP-235 (Mitsubishi paper) TP50KJ-R (Nippon paper) HA220AA (Nippon paper)

■ FUNCTION

ITEM		ITEM	
1.	Test printing	8.	Cutter trouble detection
2.	Paper-out detection	9.	Motor power save
3.	Paper near end detection	10.	Mark detection
4.	Head-up detection	11.	MCU trouble detection
5.	Abnormal temp. of thermal head detection	12.	Power on/off sequence protection
6.	Blown fuse detection	13.	Motor protection
7.	Abnormal voltage detection of head	14.	Hardware timer

■ DIMENSIONS

1. Printer mechanism / cutter

FTP-639MCL364#70-R

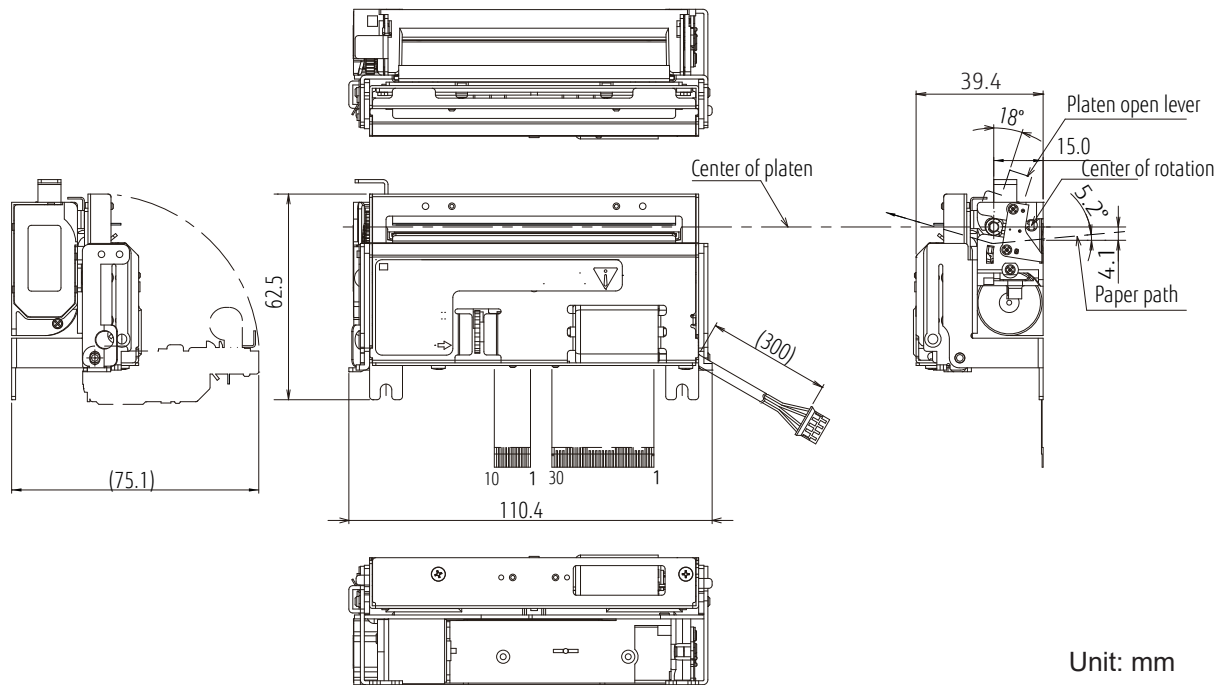

■ CONNECTOR PIN ASSIGNMENT OF PRINTER MECHANISM (FPC)

1. Thermal head control circuit side

Part number : 52610-3071 (Molex) or equivalent

No	Signal	I/O	Contents	No	Signal	I/O	Contents
1	SW	O	Platen open switch	2	SW	-	Platen open switch
3	VH	I	Power for thermal head	4	V-	I	Power for thermal head
5	VH	I	Power for thermal head	6	V-	I	Power for thermal head
7	DI	I	Data in	8	STB2	I	Print enable 2
9	NC	-	Not connected	10	VDD	-	Power for logic
11	TM	-	Head Thermistor	12	GND	-	Head GND
13	GND	-	Head GND	14	GND	-	Head GND
15	GND	-	Head GND	16	GND	-	Head GND
17	GND	-	Head GND	18	GND	-	Head GND
19	GND	-	Head GND	20	GND	-	Head GND
21	TH	O	Thermistor	22	STB1	I	Print enable 1
23	NC	-	Not connected	24	$\overline{\text{LAT}}$	I	Print data latch
25	CLK	I	Clock	26	DO	O	Data out
27	VH	I	Power for thermal head	28	VH	I	Power for thermal head
29	VH	I	Power for thermal head	30	VH	I	Power for thermal head

2. Motor, Sensor (CN4)

Connector on circuit side : 52610-1071 (Molex) or equivalent

No.	Signal	I/O	Contents	No.	Signal	I/O	Contents
1	NC	-	Not connected	2	TM	O	Motor temperature sensor
3	TM	-	Motor temperature sensor	4	$\overline{\text{MT A}}$	I	Motor coil excitation /A
5	MT A	I	Motor coil excitation A	6	$\overline{\text{MT B}}$	I	Motor coil excitation /B
7	MT B	I	Motor coil excitation B	8	PHK	-	Paper out sensor cathode
9	VSEN	-	Power for paper sensor	10	$\overline{\text{PHE}}$	O	Paper out sensor emittor

3. Cutter (CN5)

Connector type: B4B-PH (J.S.T.) or equivalent

No.	Signal	I/O	Contents	No.	Signal	I/O	Contents
1	SW1	O	Cutter home position switch	2	SW2	O	Cutter home position switch
3	M+	I/O	Cutter motor drive	4	M-	I/O	Cutter motor drive

■ INTERFACE COMMAND OPTIONS

Please refer to the FTP-629DSL301 series datasheet

Contact

Japan

FCL COMPONENTS LIMITED
Shinagawa Seaside Park Tower
12-4, Higashi-shinagawa 4-chome,
Tokyo 140 0002, Japan
Tel: +81 3 3450 1682
Email: fcl-contact@cs.fcl-components.com

North and South America

FCL COMPONENTS AMERICA, INC.
2055 Gateway Place, Suite 480
San Jose, CA 95110 U.S.A.
Tel: +1 408 745 4900
Email: contact@fcl-components.us

Web: www.fcl-components.com/en/

Europe

FCL COMPONENTS EUROPE B.V.
Diamantlaan 25
2132 WV Hoofddorp
Netherlands
Tel: +31 23 5560910
Email: info@fcl-components.eu

Asia Pacific

FCL COMPONENTS ASIA, LTD.
51 Changi Business Park Central, #06-07
Singapore 486066
Tel: +65 6375 8560
Email: fcal@fcl-components.com

China

FCL COMPONENTS (SHANGHAI) CO., LTD.
Unit 1105, Central Park –Jing An, No.329 Heng Feng
Road, Shanghai 200070, China
Tel: +86 021 3253 0998
Email: fcsh@fcl-components.com

Hong Kong

FCL COMPONENTS HONG KONG Co., LIMITED
Room 13, 23/F, Seapower Tower, Concordia Plaza,
No.1 Science Museum Road,
Tsim Sha Tsui East, Kowloon, Hong Kong
Tel: +852 2881 8495
Email: fcsh@fcl-components.com

Copyright

All trademarks or registered trademarks are the property of their respective owners. FCL Components America or its affiliates do not warrant that the content of datasheet is error free. In a continuing effort to improve our products FCL Components America, Inc. or its affiliates reserve the right to change specifications/datasheets without prior notice.

Copyright ©2026 FCL Components America, Inc. All rights reserved. Revised March 9, 2026.
