

FUJITSU Component Thermal Printer FTP-62GMCL473 series

Fujitsu 2" high speed thermal printer mechanism with cutter

Overview

The compact, ultra low profile design FTP-62GMCL series thermal printer (driven by 12VDC or 24VDC) provides high speed printing (120mm/s at 12VDC or 200mm/s at 24VDC) for 2-inch wide paper.

The series is suitable for a variety of applications, such as POS/ECR, kiosk terminals, ticket machines, label printers, banking machines, measuring devices, medical equipment, etc.

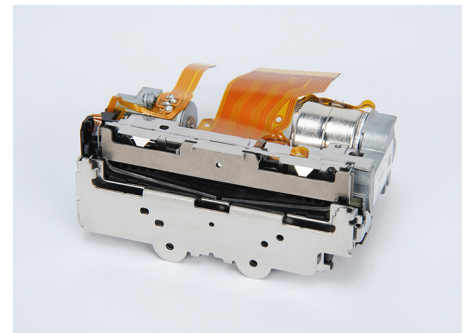

FTP-62GMCL473/473#01

Features

- High-speed printing
It can print at 120mm/s (960 dotlines/s) at 12VDC or 200mm/s (1,600 dotlines/s) at 24VDC maximum by using Fujitsu Components' unique head drive control
- Rear paper insertion mechanism with lock type
Fujitsu Components' unique platen release mechanism allows for a straight paper path and easy head maintenance
- Auto cutter
Ultra-low profile auto cutter (full/partial cut) mounted at the factory
- Multi-featuring diecast frame
The rugged die-cast frame provides excellent ESD performance, is shock/vibration resistant and the heat-sink allows for continuous printing
- Compact size
Depth: 34.8mm, width: 80.5mm, height: 45.6mm
- High resolution
8 dots/mm head provides clear print
- UL recognized, file # E171434
- RoHS compliant

■ Part numbers

Item		Part Number
Printer mechanism	Back insertion	FTP-62GMCL473 (58mm paper width)
		FTP-62GMCL473#01 (60mm paper width)
LSI for driving		Under development
Interface board	12VDC	Serial (RS232C, USB)
		Serial (RS232C, USB)
	24 VDC	Under development
Interface cable	Serial	FTP-62GY302
	USB	FTP-62GY311#01
Power supply cable	Logic, head, motor	FTP-629Y603

■ Specifications

Item	Specifications	
Part number	FTP-62GMCL473	FTP-62GMCL473#01
Printing method	Thermal sensitive line dot method	
Dot structure	432 dots/lines	
Dot pitch (horizontal)	0.125mm (8 dots/mm) - Dot density	
Dot pitch (vertical)	0.125mm (8 dots/mm) - Line feed pitch	
Effective printing area	54mm	
Number of columns	ANK 36 columns/line	
Paper width	58mm +0/-1	60mm +0/-1
Paper thickness	60-100 μ m*1	
Cutting type	Full or partial	
Printing speed	12VDC	120mm/s (960 dot lines/s)
	24VDC	200mm/s (1,600 dot lines/s)
Character types	Alphanumeric KANA	159 types
	International and special	195 types
	OCR I	103 types
	OCR III	23 types
	OCR IV	103 types
	Extended numeric	12 types
JIS KANJI level 1, 2, non-Kanji	JIS KANJI: approx. 6800 (FTP-628GDSL101#01)	
	13, 503 (FTP-62GDSL101#02)	
Character dimensions (W x H), number of characters	8 x 16 dots, 54 columns, ANK	24 x 40 dots, 18 columns, OCR I
	12 x 24 dots, 36 columns, ANK	24 x 48 dots, 18 columns, OCR II
	16 x 16 dots, 27 columns, ANK	36 x 60 dots, 12 columns, OCR IV
	24 x 24 dots, 18 columns, ANK	24 x 48 dots, 18 columns, extended numeric

*1: there may be exceptions

Item	Specifications	
Part number	FTP-62GMCL473	FTP-62GMCL473#01
Power	For head	10.8VDC to 26.4VDC, 2.6A at 12VDC, 5.3A at 24VDC (concurrent applied dot number: 128 dots)
	For printer motor	10.8VDC to 26.4VDC, 1.5A maximum
	For logic	3.3 or 5VDC \pm 5% 75mA maximum
Dimensions (WxDxH)	Printer mechanism	80.5 x 45.6 x 34.8mm
	Interface board (DSL)	70 x 37mm
Weight	Printer mechanism	135g
	Interface board (DSL)	15g
Expected life	Head	Pulse durability: 100 million pulse/dot (using Fujitsu Components' standard driving method) Wear resistance: 100km (at 12.5% print ratio)
Cutter		1,000,000 cuts min.*2
Environmental conditions	Operating temperature	+5°C to +40°C (guarantee)
	Operating humidity	20 to 85% RH (no condensation)
	Storage temperature	-40°C to +70°C (excluding paper)
	Storage humidity	5 to 95% RH (no condensation)
Detection functions	Head temperature	By thermistor
	Paper out/Mark detect	By photointerrupter
	Head release	By slide switch
Recommended thermal sensitive paper	High sensitive paper	TF50KS-E45 (Nippon paper)
	Standard paper	TF-60KS-E (Nippon paper)
		PD150R (Oji paper)
	Medium term paper	TF-60KS-F1 (Nippon paper) P220VBB-1 (Mitsubishi paper)
Long term paper	PD160R (Oji paper) TP50KJ-R (Nippon paper) HA220AA (Mitsubishi paper)	

*2: Under conditions of 25 \pm 5°C, 40 to 60% RH, cut cycle: min. 3 sec., max. 20 cuts per min.

■ Dimensions

- Printer mechanism: 2-inch, with cutter

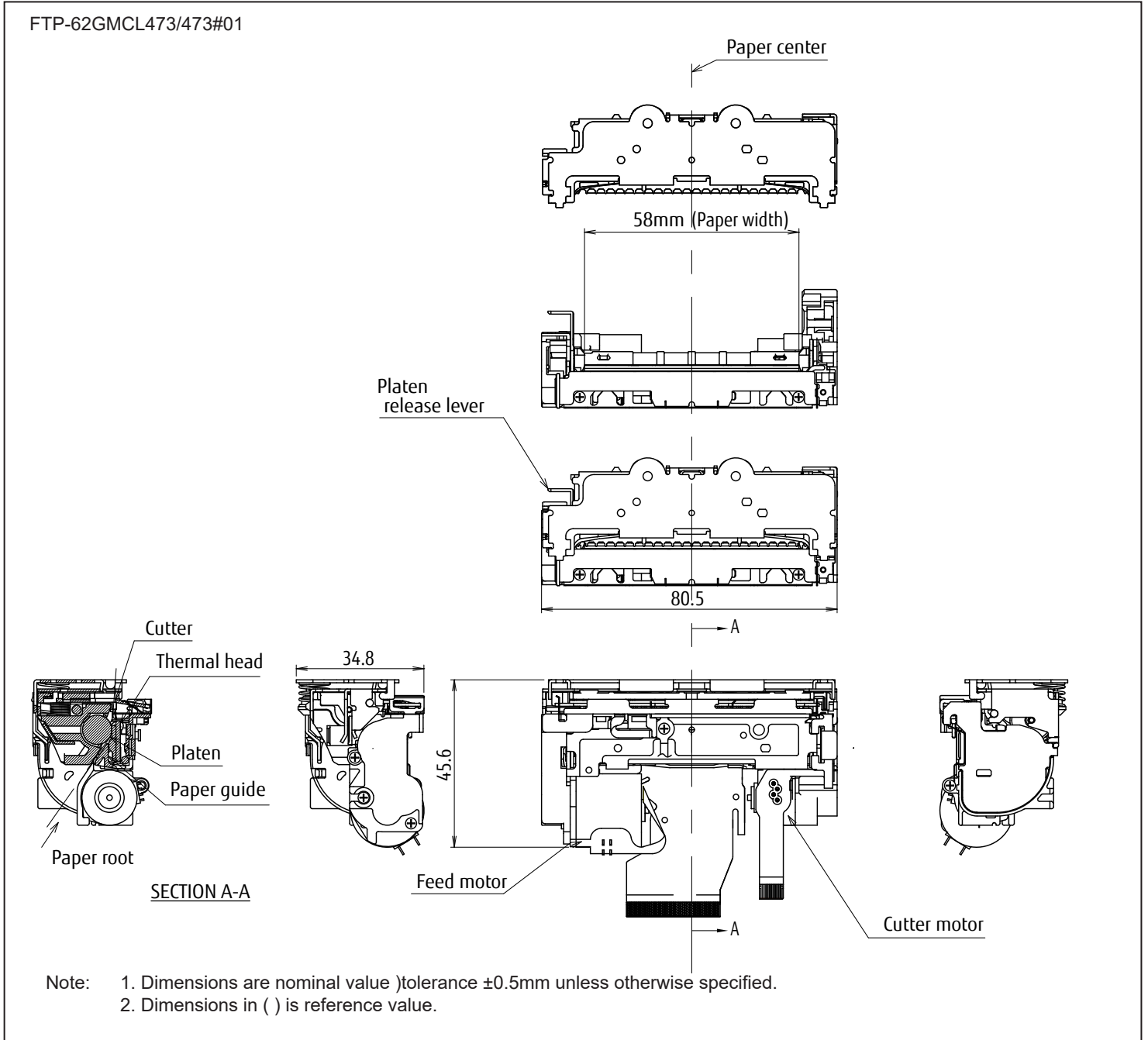

■ Connector pin assignments of printer mechanism (FPC)

Recommended connector of head FPC: 54104-5031 (Molex) or equivalent

No	Signal	Content	I/O
1	VSEN	Paper sensor power	IN
2	PHK	Cathode for photo interrupter	OUT
3	PHE	Emitter for photo interrupter	OUT
4	N.C.	Not connected	-
5	VH	Head drive power	IN
6	VH	Head drive power	IN
7	VH	Head drive power	IN
8	VH	Head drive power	IN
9	VH	Head drive power	IN
10	VH	Head drive power	IN
11	DI	Data in	IN
12	/STB2	/Strobe2	IN
13	/STB3	/Strobe3	IN
14	VDD	Logic power	IN
15	GND	Head ground	-
16	GND	Head ground	-
17	GND	Head ground	-
18	GND	Head ground	-
19	GND	Head ground	-
20	GND	Head ground	-
21	GND	Head ground	-
22	GND	Head ground	-
23	GND	Head ground	-
24	GND	Head ground	-
25	GND	Head ground	-
26	GND	Head ground	-
27	TM	Thermistor	OUT
28	N.C.	Not connected	-
29	/STB1	/Strobe1	IN
30	/LAT	/Data latch	IN
31	CLK	Clock	IN
32	VH	Head drive power	IN
33	VH	Head drive power	IN
34	VH	Head drive power	IN
35	VH	Head drive power	IN
36	VH	Head drive power	IN
37	VH	Head drive power	IN
38	N.C.	Not connected	-
39	SW	Platen switch release	OUT
40	SW	Platen switch release	OUT
41	MTM	Motor thermistor	OUT

No	Signal	Content	I/O
42	MTM	Motor thermistor	OUT
43	MT_/A	Excitation signal /A	SINK/SOURCE
44	MT_/A	Excitation signal /A	SINK/SOURCE
45	MT_A	Excitation signal A	SINK/SOURCE
46	MT_A	Excitation signal A	SINK/SOURCE
47	MT_/B	Excitation signal /B	SINK/SOURCE
48	MT_/B	Excitation signal /B	SINK/SOURCE
49	MT_B	Excitation signal B	SINK/SOURCE
50	MT_B	Excitation signal B	SINK/SOURCE

- Connector pin assignments of cutter (FPC)
Recommended connector of cutter motor FPC: 52745-1297 (Molex) or equivalent

No	Signal	Content	I/O
1	MT_B	Excitation signal B	SINK/SOURCE
2	MT_B	Excitation signal B	SINK/SOURCE
3	MT_/B	Excitation signal /B	SINK/SOURCE
4	MT_/B	Excitation signal /B	SINK/SOURCE
5	MT_A	Excitation signal A	SINK/SOURCE
6	MT_A	Excitation signal A	SINK/SOURCE
7	MT_/A	Excitation signal /A	SINK/SOURCE
8	MT_/A	Excitation signal /A	SINK/SOURCE
9	N.C.	Not connected	-
10	VSEN	Paper sensor power	IN
11	PHE	Emitter for photo interrupter	OUT
12	PHK	Cathode for photo interrupter	OUT

Contact

Japan
FUJITSU COMPONENT LIMITED
Shinagawa Seaside Park Tower
12-4, Higashi-shinagawa 4-chome,
Tokyo 140 0002, Japan
Tel: (81-3) 3450-1682
Email: fcl-contact@cs.fcl-components.com

Europe
FUJITSU COMPONENTS EUROPE B.V.
Diamantlaan 25
2132 WV Hoofddorp
Netherlands
Tel: (31-23) 5560910
Email: info.fceu@cs.fcl-components.com

China
FUJITSU ELECTRONIC COMPONENTS
(SHANGHAI) CO., LTD.
Room 4306, BM Intercontinental Business Center,
100 Yutong Rd, Shanghai 200070, China
Tel: (86 21) 3253 0998
Email: fcsh@fcl-components.com

North and South America
FUJITSU COMPONENTS AMERICA, INC.
350 Cobalt Way, M/s 160
Sunnyvale, CA 94085 U.S.A.
Tel: (1-408) 745-4900
Email: fcai.components@fcl-components.com

Asia Pacific
FUJITSU COMPONENTS ASIA, Ltd.
No. 20 Harbour Drive, #07-01B
Singapore 117612
Tel: (65) 6375-8560
Email: fcal@fcl-components.com

Hong Kong
FUJITSU COMPONENTS HONG KONG Co., Ltd.
Room 13, 23/F, Seapower Tower, Concordia Plaza,
No.1 Science Museum Road,
Tsim Sha Tsui East, Kowloon, Hong Kong
Tel: (852) 2881 8495
Email: fcsh@fcl-components.com

Web: www.fcl.fujitsu.com/en/

Copyright

All trademarks or registered trademarks are the property of their respective owners. Fujitsu Components America or its affiliates do not warrant that the content of datasheet is error free. In a continuing effort to improve our products Fujitsu Components America, Inc. or its affiliates reserve the right to change specifications/datasheets without prior notice.
Copyright ©2023 Fujitsu Components America, Inc. All rights reserved. Revised January 10, 2023.