

FCL COMPONENTS

BATTERY DRIVEN, FTP-608 Series 2" HIGH SPEED THERMAL PRINTER

FTP-628MCL401#01/451#01

■ OVERVIEW

The FTP-628 MCL Series are battery driven high-speed printers with a 2-inch paper width equivalent.

The FTP-628 MCL Series can be used for a variety of applications, such as portable terminals, POS, banking terminals, and measurement and medical equipment.

■ HIGHLIGHTS

- **Ultra low profile**
Height 21.8 mm, width 81.2 mm, depth 42.2 mm
- **High speed printing**
It can print at 80 mm/s (640 dotlines/s) at 9.5V head voltage maximum
- **Auto Cutter**
Full cut type and partial cut type printers are available by user selection.
- **Easy paper loading**
Our unique platen release mechanism allows a wide paper route even if the printer is ultra-compact, so paper can be easily inserted.
- **Multifunctional die-cast form**
Wide operating temperature range, long continuous printing, high ESD absorption and discharge of static electricity vibration and shock resistant.
- **RoHS compliant**



FTP-628MCL401#01



FTP-628DSL491R

FTP-628MCL401#01 / 451#01

■ PART NUMBERS

Name		Part Number
Printer mechanism with cutter		FTP-628MCL401#01 (Easy Load Model)
Printer mechanism without cutter		FTP-628MCL451#01 (Easy Load Model with platen bracket + lock lever)
LSI for driving		FTP-629CU451R
Interface board for Mechanism/Cutter	Cutter supported	FTP-628DSL491R Parallel (Centronics) / Serial (RS-232C)
Interface cable	Parallel (Centronics)	FTP-628Y202
	Serial (RS-232C)	FTP-628Y302
Power cables	Head, motor, logic	FTP-628Y402

■ SPECIFICATIONS

Item	Specifications
Part number	FTP-628MCL401#01/451#01
Printing method	Thermal-line dot method
Dot structure	384 dots/line
Dot pitch (Horizontal)	0.125 mm (8 dots/mm)—Dot density
Dot pitch (Vertical)	0.125 mm (8 dots/mm)—Line feed pitch
Effective printing area	48 mm
Number of columns	ANK 32 columns/line (maximum 12 x 24 dot font)
Paper width	58 mm
Paper thickness	60 to 85 μ m (some paper in this range may not be used because of paper characteristics)
Printing Speed	Maximum 80mm/sec. (640dotline/sec.) at 9.5V *1 Maximum 60mm/sec.(480 dotline/sec.) at 8.5V *2
Character types	Alphanumeric, kana: 159 types International characters: 195 types JIS Kanji (Kanji CG loaded board): about 6800 types
Character, dimensions (W×H), number of columns	12 × 24 dots, (1.5 × 3.0 mm), 32 columns: ANK 24 × 24 dots, (3.0 × 3.0 mm), 16 columns: ANK 8 × 16 dots, (1.0 × 2.0 mm), 48 columns: ANK 16 × 16 dots, (2.0 × 2.0 mm), 24 columns: ANK

Notes:

*1: Head voltage 9.5V, use standard papper, ambient temperature 25°C, concurrent applied dots 64 dots maximum, printing energy S.L.T.(Scan Line Time)=1.56ms/line, EOMax=0.27mJ/dot maximum.

*2: Head voltage 8.5V, use standard papper, ambient temperature 25°C, concurrent applied dots 64 dots maximum, printing energy S.L.T.(Scan Line Time)=2.08ms/line, EOMax=0.32mJ/dot maximum.

FTP-628MCL401#01 / 451#01

■ SPECIFICATIONS

Item		Specification
Interface		Conforms to RS232C / Centronics
Power supply	For print head	4.2 to 9.5VDC, 2.4A (Head voltage 7.2VDC, resistance 176Ω, 25°C, concurrent applied dots 64 dots)
	For motor	4.75 to 9.5VDC, 0.75A maximum
	For cutter motor	4.75 to 9.5VDC, 1.0A maximum
	For logic	3.3 or 5VDC +/-10%, 0.1A maximum
Dimensions	Mechanism with cutter	81.2 x 42.2 x 21.8 mm (WxDxH)
	Interface board	70 x 60 x12 mm
Weight	Mechanism with cutter	Approximately 100g
	Interface board	Approximately 25g
Life	Head	Pulse resistance: 100 million pulses/dot (under our standard conditions); Abrasion resistance: paper traveling distance 50km (print ratio: 25% or less)
	Cutter	500,000 cuts
	Platen	5,000 times (open/close)
Operating environment	Operating temperature*	+5° to +40°C (guarantee)
	Operating humidity	20 to 85% RH (no condensation)
	Storage temperature	-20° C to +60° C (paper not included)
	Storage humidity	5 to 90% RH (no condensation)
Detection function	Head temperature detection	Detected by thermistor
	Paper out/mark detection	Detected by photo-interrupter
	Platen release	Detected by sliding switch
	Movable blade	Detected by photo-interrupter
Recommended thermal sensitive paper	High Sensitive Paper	TF50KS-E4 (Nippon Paper)
	Standard paper:	TF60KS-E(Nippon Paper), PD105R (Oji Paper)
	Medium Life Paper	TF60KS-F1, PD170R (Oji Paper), P220VBB-1 (Mitsubishi Paper)
	Long Life Paper	PD160R-N (Oji Paper), AFP-235 (Mitsubishi Paper), TP50KJ-R (Nippon Paper), HA220AA (Nippon Paper)

■ FUNCTION OF INTERFACE BOARD

Item	Item
1. Test print function	8. Cutter trouble detect
2. Paper out detection	9. Motor power saving function
3. Paper near end detection	10. Mark detection function
4. Platen open detection	11. MCU operation abnormality detection
5. Thermal head temperature abnormality detection	12. Power ON/OFF sequence protection
6. Blow-out fuse detection	13. Motor over-current protection
7. Head voltage abnormality detection	14. Hardware timer

■ DIMENSIONS

1. Printer mechanism

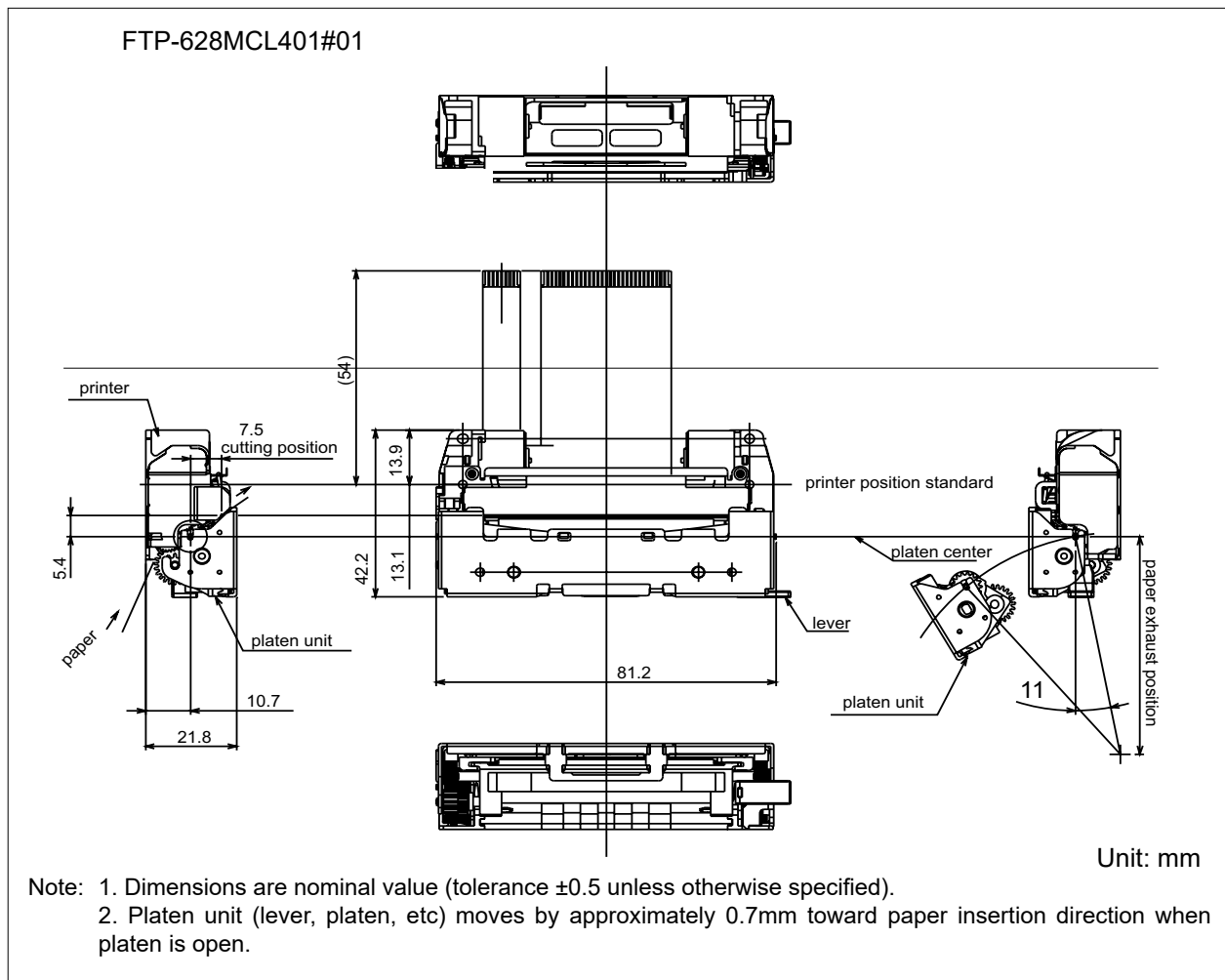

FTP-628MCL401#01 / 451#01

1. Printer mechanism

FTP-628MCL451#01

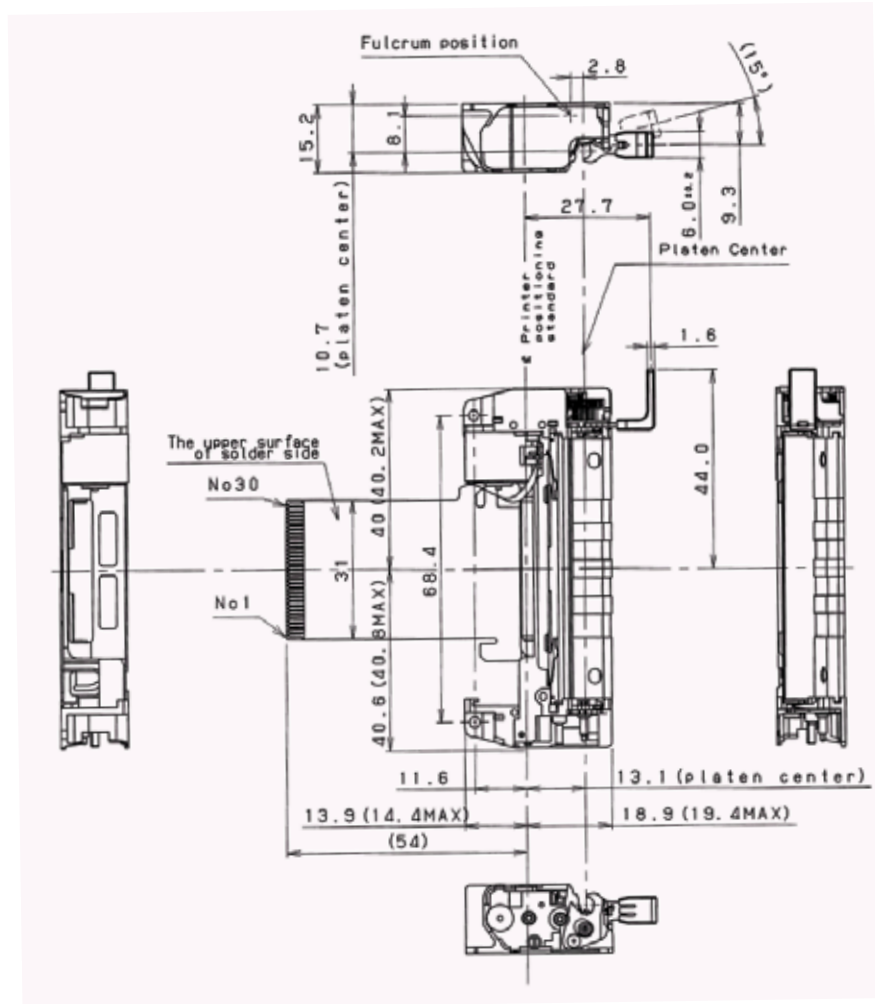

FTP-628MCL401#01 mechanism/cutter FPC PIN Assignment

(1) For thermal head, motor and sensor

Connector on control circuit: 52610-3071 (Molex or equivalent)

No	Signal	I/O	Contents
1	PHK	-	Cathode for photo interruptor
2	VSEN		Paper sensor power
3	PHE	O	Emitter for photo interruptor
4	VH		Head drive power
5	VH		
6	DI		Data in
7	CLK		Clock
8	GND	-	Head ground
9	GND	-	
10	STB6		Strobe 6
11	STB5		Strobe 5
12	STB4		Strobe 4
13	Vdd		Logic power
14	TM	O	Thermistor
15	TM	O	
16	STB3		Strobe 3
17	STB2		Strobe 2
18	STB1		Strobe 1
19	GND	-	Head ground
20	GND	-	
21	$\overline{\text{LAT}}$		Data latch
22	DO	O	Data out
23	VH		Head drive power
24	VH		
25	$\overline{\text{SW}}$		Platen release switch
26	SW	O	
27	$\overline{\text{MT A}}$		Excitation signal $\overline{\text{A}}$
28	MT A		Excitation signal A
29	$\overline{\text{MT B}}$		Excitation signal $\overline{\text{B}}$
30	MT B		Excitation signal B

FTP-628MCL451#01 mechanism/platen bracket FPC PIN Assignment

(1) For thermal head, motor and sensor

Connector on control circuit: 52610-3071 (Molex or equivalent)

No	Signal	I/O	Contents
1	PHK	-	Cathode for photo interruptor
2	VSEN		Paper sensor power
3	PHE	O	Emitter for photo interruptor
4	VH		Head drive power
5	VH		
6	DI		Data in
7	CLK		Clock
8	GND	-	Head ground
9	GND	-	
10	STB6		Strobe 6
11	STB5		Strobe 5
12	STB4		Strobe 4
13	Vdd		Logic power
14	TM	O	Thermistor
15	TM	O	
16	STB3		Strobe 3
17	STB2		Strobe 2
18	STB1		Strobe 1
19	GND	-	Head ground
20	GND	-	
21	<u>LAT</u>		Data latch
22	DO	O	Data out
23	VH		Head drive power
24	VH		
25	SW		Platen release switch
26	SW	O	
27	MT <u>A</u>		Excitation signal <u>A</u>
28	MT A		Excitation signal A
29	MT <u>B</u>		Excitation signal <u>B</u>
30	MT B		Excitation signal B

FTP-628MCL401#01 cutter FPC PIN Assignment

(2) For cutter

Connector on control circuit: 52610-0871 (Molex or equivalent)

No	Signal	I/O	Contents
1	VSEN		Home position sensor power
2	PHE	O	Emitter for photo interruptor
3	PHK	-	Cathode for photo interruptor
4	MT A		Excitation signal A
5	MT <u>A</u>		Excitation signal <u>A</u>
6	MT B		Excitation signal B
7	MT <u>B</u>		Excitation signal <u>B</u>
8	NC	-	Not connected

