

LOW VOLTAGE FTP-608 Series 2" HIGH SPEED THERMAL PRINTER

FTP-628MCL113#01 Easy Loading Method

■ OVERVIEW

The FTP-608MCL series is an ultra compact, high speed, low voltage printer mechanism that supports 2" paper width (58mm). The removable platen design simplifies both paper loading and maintenance.

This series can be used for a variety of applications such as portable terminals, POS systems, kiosks, ATM's as well as test and measurement equipment.

■ HIGHLIGHTS

- **Easy loading type**
Platen removal design simplifies paper loading and maintenance.
- **Easy mounting platen**
Platen bracket allows for easy attachment to cover. Also includes a unique platen release lever.
- **Ultra compact**
Height 15.5 mm, width 75 mm, depth 33.4 mm for the 2 inch model, excluding platen unit.
- **High speed printing**
It can print at 100 mm/sec. (800 dotlines/sec.) maximum at 9.5V by using FCL Components' unique head drive control.
- **High resolution printing**
8 dots/mm of resolution printing is possible.
- **RoHS compliant**

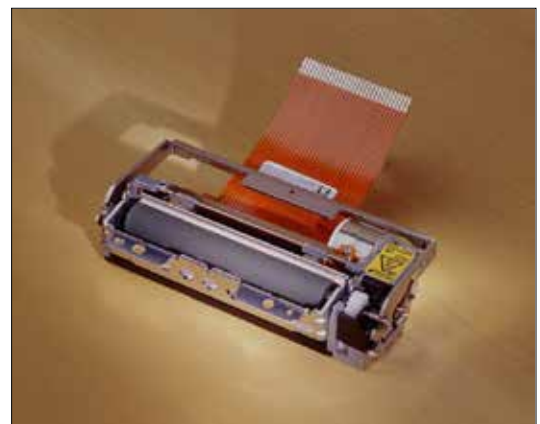

FTP-628MCL113#01

■ PART NUMBERS

Item		Part number
Printer mechanism		FTP-628MCL113#01 (with platen bracket and platen detect switch)
LSI for driving		FTP-628CU311-R
Interface board	USB/RS-232C	FTP-628DSL311-R, FTP-628DSL312-R*
Interface cables	Serial	FTP-628Y302
	USB	FTP-629Y301#01-R
Power cable	Head, motor, logic	FTP-628Y403

*: This interface board accepts a 21.6V - 26.4V input

■ SPECIFICATIONS

Item	Specifications
Part number	FTP-628MCL113#01
Printing method	Thermal-line dot method
Dot structure	384 dots/line
Dot pitch (Horizontal)	0.125 mm (8 dots/mm)—Dot density
Dot pitch (Vertical)	0.125 mm (8 dots/mm)—Line feed pitch
Effective printing area	48 mm
Number of columns	ANK 32 columns/line (maximum 12x 24 dot font)
Paper width	58 mm +0/-1
Paper thickness	60 to 100 μ m (some paper in this range may not be used because of paper characteristics)
Printing Speed*	Maximum 100mm/sec. (800 dotline/sec.) at 9.5V Maximum 80mm/sec. (640 dotline/sec.) at 8.5V
Character types	Alphanumeric, katakana: 159 types International and special characters: 195 types JIS Kanji level 1, level 2, non-Kanji (supported only when Kanji CG is mounted): about 6800 types
Character, dimensions (H×W), number of columns	12 × 24 dots, (1.5 × 3.0mm), 32 columns: ANK 24 × 24 dots, (3.0 × 3.0mm), 16 columns: ANK, Kanji 8 × 16 dots, (1.0 × 2.0 mm), 48 columns: ANK 16 × 16 dots, (2.0 × 2.0 mm), 24 columns: ANK, Kanji

*: Concurrent applied dots: 64 dots or less at 25°C, batch image print, using standard paper

■ SPECIFICATIONS

Item		Specification	
		FTP-628MCL113#01	
Interface		Conforms to RS232C / USB	
Operating Voltage	For print head	4.2 VDC to 9.5 V, 2.4A, at 25°C Rav=176Ω, concurrent applied dots: 64 dots	
	For motor	4.2 VDC to 9.5 V, 0.75A maximum (average 0.56A)	
	For logic	3.3V ±10% or 5.0V±10%, 0.1A maximum	
Dimensions (WxDxH)	Printer mechanism	75.0 x 33.4 x 15.5 mm (W x D x H) (excluding FPC)	
	Interface board	67.2 x 32 x 11.2mm (W x D x H)	
Weight	Printer mechanism	Approximately 50.5g	
	Interface board	Approximately 15g	
Head life		Pulse resistance: 100 million pulses (under our standard conditions). Abrasion resistance: paper traveling distance 50km (print ratio: 25% or less)	
Operating environment	Operating temperature*	0° C to +50° C	
	Operating humidity	20 to 95% RH (no condensation)	
	Storage temperature	-20° C to +60° C (paper not included)	
	Storage humidity	5 to 95% RH (no condensation)	
Detection function	Head temperature detection	Detected by thermistor	
	Paper out/mark detection	Detected by photo-interrupter	
	Platen open/close	Slide switch	
Recommended thermal sensitive paper		High sensitive paper:	TF50KS-E4 (Nippon Paper)
		Standard paper:	TK60KS-E (Nippon Paper) PD150R (Oji Paper)
		Medium life storage paper:	TK60KS-F1 (Nippon Paper) PD170R (Oji Paper) P220VBB-1 (Mitsubishi Paper)
		Long life storage paper:	PD160R-N (Oji Paper) AFP-235 (Mitsubishi Paper) TP50KJ-R (Nippon Paper) HA220AA (Nippon Paper)

*+5°C to +40°C printing density assurance range (-25°C to 70°C capability)

■ INTERFACE BOARD FUNCTION

Item	Item
1. Test print function	6. Motor power saving function
2. Paper out detection	7. Mark detection function
3. Paper near end detection	8. MCU operation abnormality detection
4. Thermal head temperature abnormality detection	9. Platen detect open
5. Head voltage abnormality detection	

■ DIMENSIONS

1. Printer mechanism

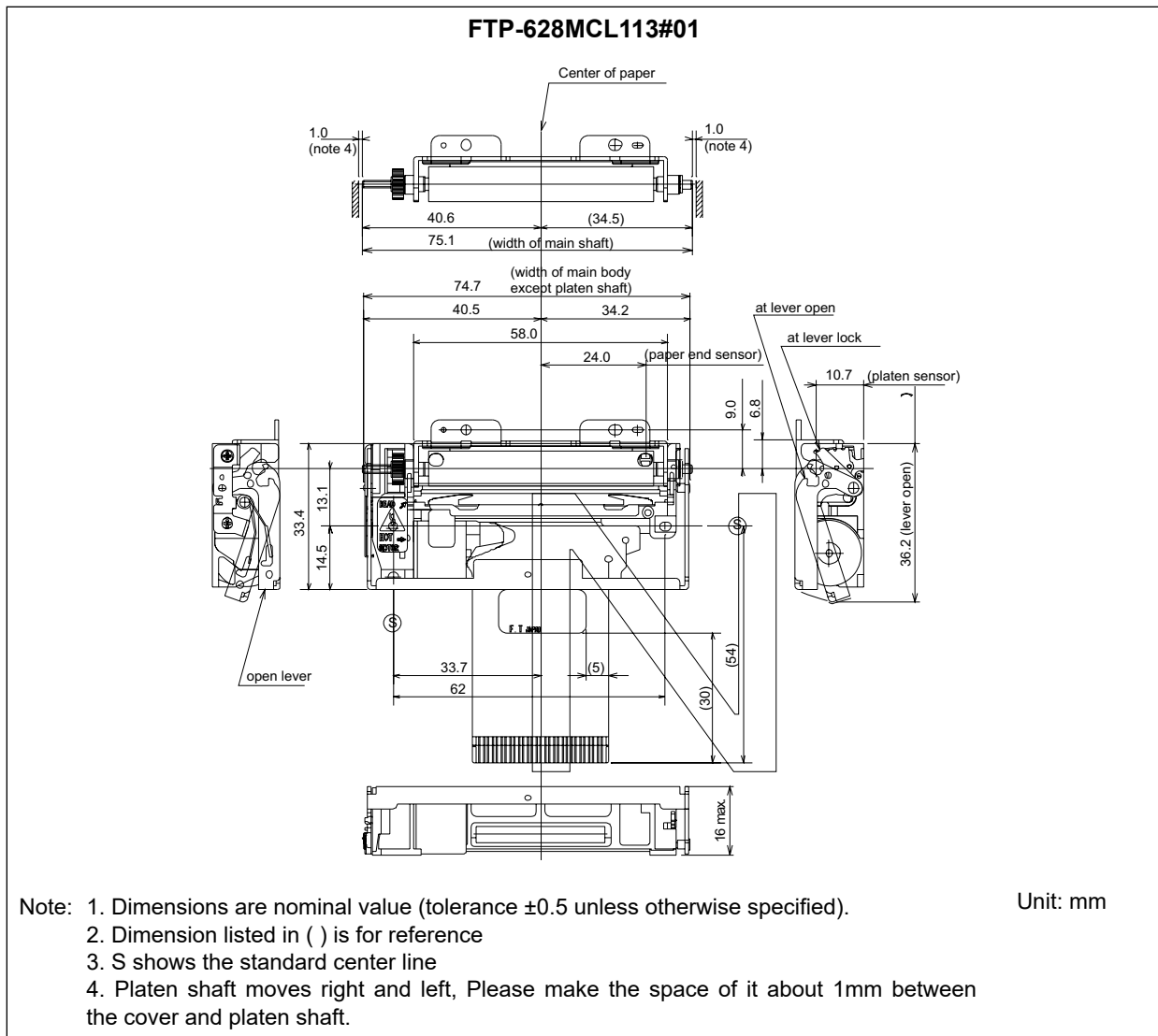

■ PRINTER CONNECTOR (FLEXIBLE PT BOARD) PIN ARRAYS FTP-628 MCL113#01

Thermal head, control circuit side connector: 52610-3071 Molex or equivalent product

No	Signal	I/O	Contents
1	PHK	O	Cathode for photo interruptor
2	VSEN	I	paper sensor power
3	PHE	O	Emittor for photo interruptor
4	SW1	-/	Platen release switch
5	SW2	-/	Platen release switc
6	COM		Head drive power
7	COM		
8	SI		Data in
9	CLK		Synchronous clock for communication
10	GND	—	Ground power supply for thermal head
11	GND	—	
12	STB6	I	Thermal head energizing control signal
13	STB5	I	
14	STB4	I	
15	VDD	I	Logic power
16	TH	O	Thermally sensitive resistor input termnial 1
17	TH	O	Thermally sensitive resistor input termnial 2
18	STB3	I	Thermal head energizing control signal
19	STB2	I	
20	STB1	I	
21	GND	—	Ground power supply for thermal head
22	GND	—	
23	$\overline{\text{LAT}}$	I	Data latch
24	SO	O	Data out
25	COM		Power supply for thermal head
26	COM		
27	MT A	I	Stepping motor excitation signal
28	$\overline{\text{MT A}}$	I	
29	MT B	I	
30	$\overline{\text{MT B}}$	I	

Do not plug or unplug the FPC when power is on.

Contact

Japan

FCL COMPONENTS LIMITED
Shinagawa Seaside Park Tower
12-4, Higashi-shinagawa 4-chome,
Tokyo 140 0002, Japan
Tel: +81 3 3450 1682
Email: fcl-contact@cs.fcl-components.com

Europe

FCL COMPONENTS EUROPE B.V.
Diamantlaan 25
2132 WV Hoofddorp
Netherlands
Tel: +31 23 5560910
Email: info@fcl-components.eu

China

FCL COMPONENTS (SHANGHAI) CO., LTD.
Unit 1105, Central Park –Jing An, No.329 Heng
Feng Road, Shanghai 200070, China
Tel: +86 021 3253 0998
Email: fcsh@fcl-components.com

North and South America

FCL COMPONENTS AMERICA, INC.
2055 Gateway Place, Suite 480
San Jose, CA 95110 U.S.A.
Tel: +1 408 745 4900
Email: fcmai.components@fcl-components.com

Asia Pacific

FCL COMPONENTS ASIA, LTD.
No. 20 Harbour Drive, #07-01B
Singapore 117612
Tel: +65 6375 8560
Email: fcal@fcl-components.com

Hong Kong

FCL COMPONENTS HONG KONG CO., LIMITED
Room 13, 23/F, Seapower Tower, Concordia Plaza,
No.1 Science Museum Road,
Tsim Sha Tsui East, Kowloon, Hong Kong
Tel: +852 2881 8495
Email: fcsh@fcl-components.com

Web: www.fcl-components.com/en/

Copyright

All trademarks or registered trademarks are the property of their respective owners. FCL Components America or its affiliates do not warrant that the content of datasheet is error free. In a continuing effort to improve our products FCL Components America, Inc. or its affiliates reserve the right to change specifications/datasheets without prior notice.

Copyright ©2024 FCL Components America, Inc. All rights reserved. Revised February 1, 2024.
