

FCL Components Thermal Printer FTP-628DSL311/312 series Interface Boards

FCL Components interface boards for FTP-628MCL05x, FTP-628MCL1xx, FTP-638MCLxxx series

Features

- USB (full speed) and RS-232C serial interface
- Various detection features: Paper out, mark, platen open, thermal head temperature, power supply voltage, near end
- Various alarm and protective functions: Thermal head temperature, power supply voltage, MCU operation, motor over current protection
- Print quality stabilization by the thermal head temperature and power supply voltage monitoring
- Thermal head energization can select fix division or automatic division
- Character set: ANK (Alphabet, number, Kana)
- Supports barcode printing
- Wide range of power supply voltages



FTP-628DSL311

Part numbers

Part number	Supply voltage	Interface type	Mechanism part number
FTP-628DSL311-R	4.2 to 9.5V	USB/RS-232C	FTP-628MCL05x
FTP-628DSL312-R	21.6 to 26.4V*		FTP-628MCL1xx FTP-638MCL1xx

*: The FTP-628DSL312 will convert the input voltage, 21.6V - 26.4V, to 9.5V to drive the FTP-6x8MCL mechanisms

Interface specification at host side

Item	Specifications												
RS-232C	Data speed: 9.6k, 19.2k, 38.4k, 115.2k, 230.4k bps** Synchronous method: Asynchronous Handshake: RTS (DTR) / CTS (DSR) control, XON/XOFF control Parity: Non, even, odd** Input/output level: RS-232C level												
USB V2.0	Data speed: USB ver 2.0 full speed (12Mbps max.) USB interface class: <table style="margin-left: 20px;"> <tr> <td>Device class:</td> <td>Printer device</td> </tr> <tr> <td>Interface class:</td> <td>Printer</td> </tr> <tr> <td>Sub class:</td> <td>Printer</td> </tr> <tr> <td>Protocol:</td> <td>Unidirectional interface</td> </tr> </table> Endpoint: <table style="margin-left: 20px;"> <tr> <td>EPO:</td> <td>Control</td> </tr> <tr> <td>EP1:</td> <td>Bulk OUT</td> </tr> </table>	Device class:	Printer device	Interface class:	Printer	Sub class:	Printer	Protocol:	Unidirectional interface	EPO:	Control	EP1:	Bulk OUT
Device class:	Printer device												
Interface class:	Printer												
Sub class:	Printer												
Protocol:	Unidirectional interface												
EPO:	Control												
EP1:	Bulk OUT												

** : Selectable by RS-232C communication conditions setting command GS (+E(fn=67))

■ Specifications

1.1 Base specifications

Item	Specifications
Dimensions	67.2 x 32.0mm (WxD)
Weight	Approx. 15g

1.2 Print/paper feed specifications

Item	Specifications
Part number	FTP-628MCL (2-inch) FTP-638MCL (3-inch)
Dot pitch	0.125mm (H) x 0.125mm (W)
Number of dots	384 dots/line 576 dots/line
Max. printing width	48mm 72mm
Line space	Approx. 1/8 inch (26 dots line)
Print speed*1	100mm/s 60mm/s
Paper feed speed (/ATF)	Approx. 30mm/s

*1: Conditions:

Paper:	PD150R or equivalent
Voltage:	9.5V
Print ratio:	Up to 12.5%
Operating temperature/humidity:	25°C, 60+/-15% (no condensation)

■ Dimensions

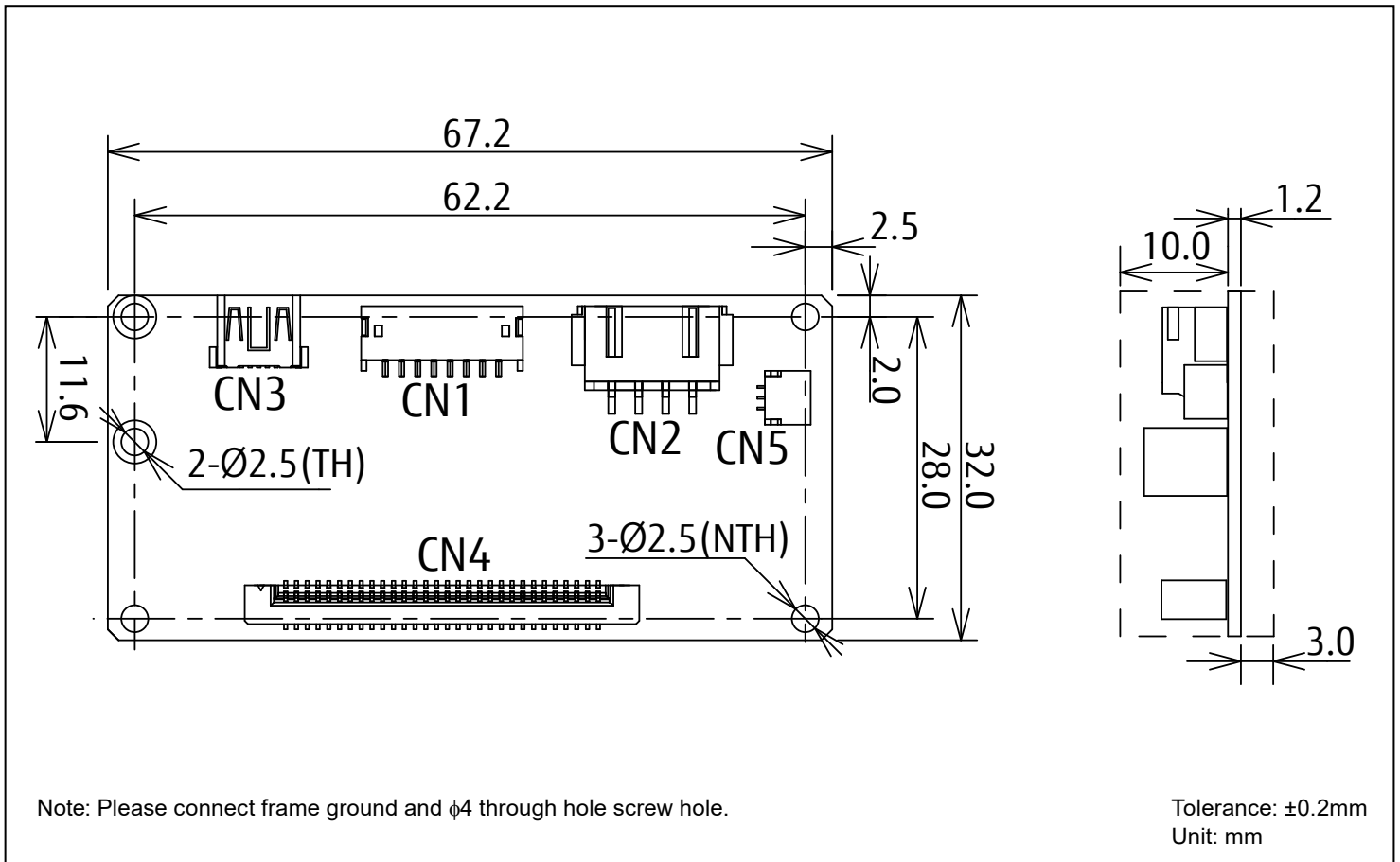

■ Control circuit board and connector types

Symbol	Name	Function	Note
CN1	Serial interface connector	Serial connection	-
CN2	Power connector	Power connection	-
CN3	USB connector	USB connection	-
CN4	Printer mechanism connector	Printer connection	-
CN5	Near end connector	Near end switch connection	-

■ Connector Pin Assignment of interface board

Note: Symbol “-” means a negative logic signal.

“I” or “O” means a signal direction from the interface board side.

• Serial interface connector (CN1)

Mating connector part number: ZHR-8 (J.S.T.) or equivalent

Recommended cable: AWG#26 to 32, cable length max. 500mm

No.	Signal	I/O	Content	No.	Signal	I/O	Content
1	RXD	I	Receive data signal	2	TXD	O	Transmission data signal
3	RTS (DTR)	O	Request to send signal	4	GND	-	Signal ground
5	CTS (DSR)	I	Clear to send signal	6	/SLCTIN	I	Dection function disabled signal
7	/INPRM	I	Initialization signal	8	/ATF	I	Paper feed

• Power connector (CN2)

Mating connector part number: XHP-4 (J.S.T.) or equivalent

Recommended cable: AWG#22 to 30, cable length max. 300mm

No.	Signal	I/O	Content	No.	Signal	I/O	Content
1	Vp	I	Power input	2	Vp	I	Power input
3	GND	-	Ground	4	GND	-	Ground

• USB Connector (CN3)

Mating connector part number: USB mini-B type

Recommended cable: Cable conforming to USB standards (V2.0 full speed)

No.	Signal	I/O	Content	No.	Signal	I/O	Content
1	Vbus	I	Vbus signal	2	D-	I/O	D- signal
3	D+	I/O	D+ signal	4	N.C.	-	Not connected
5	GND	-	Signal ground	6	FG	-	Frame ground

• Printer mechanism connector(CN4)

Please refer to the printer mechanism datasheet

• Near end Connector (CN5)

Mating connector part number: SHR-03V-S (J.S.T.) or equivalent

Recommended cable: AWG#28to 32, cable length max. 300mm

No.	Name	I/O	Description	No.	Name	I/O	Description
1	NVcc	O	Near end sensor power	2	/NES	I	Near end signal
3	GND	-	Signal ground				

■ Connector pin assignments of printer mechanism (2-inch)

Command	Content
HT	Moves print position to the next tab
LF	Line feed
FF	Feeds forms (new page)
DC2	Power down
ESC RS	Black/white reverse printing specification
ESC SP+n	Character space setting
ESC US	Black/white reverse printing cancellation
ESC !+n	Sets print mode
ESC *+m+nL+nH+d1 to dk	Bit image print
ESC -n	Undeline setting
ESC 2	Sets default line spacing
ESC 3+n	Line pitch setting
ESC @	Printer reset
ESC A+n	Line spacing setting
ESC C+n	Sets the page length line mode
ESC D+n1 to nk+NUL	Sets horizontal tab position
ESC J+n	Feeds paper in forward direction and prints
ESC R+n	Selects international character
ESC V+n	Right rotation 90° specification/cancellation
ESC X+m+n	Setting the turning time of the motor excitation
ESC a+n	Positional alignment
ESC c+1+n	Sets internal processing
ESC c+5+n	External input signal valid/invalid setting
ESC d+n	Printing and n-line feeding
ESC s+n	Sets printing speed
ESC t+n	Character code table selection
ESC {+n	Sets/resets upside down printing
FS 9+n	Sets the detection functions
FS E+n	Standard energy setting
FS r+n	Reply parameter setting
GS !+n	Character size setting
GS (+E+pL+pH+fn+d1 to d9 (fn=67)	RS-232C communication setting *1
GS (K+pL+pH+fn	Print control setting
GS(K+pL+pH+fn+n (fn=49)	Print density setting
GS(K+pL+pH+fn+n (fn=50)	Print speed setting
GS(K+pL+pH+fn+n (fn=97)	Number of head division setting
GS <	Line feeds to the next mark
GS A+m+n	Sets the line feed length after mark detection
GS E+n	Sets print quality
GS L+nL+nH	Left margin setting
GS W+nL+nH	Sets print area width
Command	Content

GS a+n	Set auto status transmission
GS e+m+n	Sets bar code width
GS h+n	Barcode height setting
GS k+m+n+d1 to dn	Bar code print
GS w+n	Bar code width magnification setting

*1: Makes write/erase to the nonvolatile memory.

Contact

Japan

FCL COMPONENTS LIMITED
Shinagawa Seaside Park Tower
12-4, Higashi-shinagawa 4-chome,
Tokyo 140 0002, Japan
Tel: +81 3 3450 1682
Email: fcl-contact@cs.fcl-components.com

Europe

FCL COMPONENTS EUROPE B.V.
Diamantlaan 25
2132 WV Hoofddorp
Netherlands
Tel: +31 23 5560910
Email: info@fcl-components.eu

China

FCL COMPONENTS (SHANGHAI) CO., LTD.
Unit 1105, Central Park –Jing An, No.329 Heng
Feng Road, Shanghai 200070, China
Tel: +86 021 3253 0998
Email: fcsh@fcl-components.com

North and South America

FCL COMPONENTS AMERICA, INC.
2055 Gateway Place, Suite 480
San Jose, CA 95110 U.S.A.
Tel: +1 408 745 4900
Email: fcai.components@fcl-components.com

Asia Pacific

FCL COMPONENTS ASIA, LTD.
No. 20 Harbour Drive, #07-01B
Singapore 117612
Tel: +65 6375 8560
Email: fcal@fcl-components.com

Hong Kong

FCL COMPONENTS HONG KONG CO., LIMITED
Room 13, 23/F, Seapower Tower, Concordia Plaza,
No.1 Science Museum Road,
Tsim Sha Tsui East, Kowloon, Hong Kong
Tel: +852 2881 8495
Email: fcsh@fcl-components.com

Web: www.fcl-components.com/en/

Copyright

All trademarks or registered trademarks are the property of their respective owners. FCL Components America or its affiliates do not warrant that the content of datasheet is error free. In a continuing effort to improve our products FCL Components America, Inc. or its affiliates reserve the right to change specifications/datasheets without prior notice.
Copyright ©2024 FCL Components America, Inc. All rights reserved. Revised February 1, 2024.