

# POWER RELAY

## 1 POLE - 3, 5A Medium Load Control (AgNi contacts)

### JY Series

#### ■ FEATURES

- Small and good for high density mounting  
 Mounting space 202mm<sup>2</sup>, height 12.8mm
- UL, CSA recognized
- High sensitivity and low power consumption  
 Operate power consumption 98mW, rated power consumption 200mW
- Wide operating range
- Plastic sealed type
- Socket mounting type and socket available
- Pin compatible with solid state relays type SJ
- Through hole
- Plastic materials: UL flammability 94V-0
- RoHS compliant.



#### ■ Applications

- Sequencer, FA equipment etc.

#### ■ Part Numbers

[Example]      JY   -   12     G   -   K     P   -   UL    
                   (a)        (b)        (c)        (d)        (e)        (f)

(a)	Relay type	JY : JY series
(b)	Coil rated voltage	12 : 4.5...48VDC
(c)	Contact rating / material / construction	W : 3A, gold overlay silver nickel, bifurcated contact G : 3A, gold flash silver nickel, single contact R : 3A, silver nickel, single contact HG : 5A, gold flash silver nickel, single contact HR : 5A, silver nickel, single contact
(d)	Enclosure	K : Plastic sealed type
(e)	Terminal type	Nil : PC board mounting type P : Socket mounting type (without JY-W)
(f)	Safety approval	Nil : Without safety standard UL : UL, CSA recognized type

Note: Actual marking omits the hyphen (-) and suffix P and UL

To be discontinued: Relays: July 2024  
Socket: October 2024

# JY Series

## ■ Specifications

Item			JY - ( ) W	JY - ( ) G	JY - ( ) R	JY - ( ) HG	JY - ( ) HR	Remarks / conditions
				3A type			5A type	
Contact data	Configuration		1a (1 form A (SPST-NO) )					
	Construction		Bifurcated (cross bar)	Single				
	Material		Gold over-lay silver nickel	Gold flash silver nickel	Silver nickel	Gold flash silver nickel	Silver nickel	
	Resistance		Max. 30 mΩ		Max. 100 mΩ	Max. 30 mΩ	Max. 100 mΩ	Initial (at 6 VDC, 1A)
	Contact rating		3A, 250VAC / 30VDC			5A, 250VAC / 30VDC		
	Max. carrying current		5A					
	Max. switching voltage		250VAC / 150 VDC					
	Max. switching power		750VA, 90W			1,250VA, 150W		
	Max. switching current		3A			5A (socket 3A)		
	Min. switching load *		0.01mA 100 mVDC	10mA 5VDC	100mA 5VDC	10mA 5VDC	100mA 5VDC	
Coil	Rated power consumption		200 mW (48V type: 360 mW)					At 20°C
	Operate power consumption		100 mW (48V type: 170 mW)					At 20°C
	Operating temperature range		-40°C ~ +90°C (48V type: +80 °C)					No frost
Timing data	Operate		Max. 6 ms					At nominal voltage (without diode, without bounce)
	Release		Max. 3 ms					At nominal voltage (without diode, without bounce)
Life	Mechanical		Min. 20 x 10 <sup>6</sup> operations					
	Electrical		Min. 100 x 10 <sup>3</sup> operations					Contact rating
Insulation	Insulation resistance		Min. 1,000MΩ at 500VDC					Initial
	Dielectric strength	Open contacts	750VAC, 1 minute					
		Coil contact	2,000VAC, 1 minute					
	Surge strength	Coil to contacts	4,000V (1.2 x 50μs standard wave)					
Other	Vibration resistance	Misoperation	10 to 55 to 10Hz single amplitude 0.75 mm					
		Endurance	10 to 55 to 10Hz single amplitude 0.75 mm					
	Shock resistance	Misoperation	Min. 100m/s <sup>2</sup> (11 ± 1ms)					
		Endurance	Min. 1,000m/s <sup>2</sup> (6 ± 1ms)					
Dimensions / weight		9.8×20.0×12.8 mm / approx. 5g						
Sealing		Plastic sealed, RTIII						

\*: Minimum switching loads mentioned above are reference values. Please perform the confirmation test with actual load before production since reference values may vary according to switching frequencies, environmental conditions and expected reliability levels.

## ■ Coil Data

code	Rated Coil Voltage (VDC)	Coil Resistance +/-10% (Ω)	Must Operate Voltage* (VDC)	Must Release Voltage* (VDC)	Rated Power (mW)
4.5	4.5	100	3.1	0.23	200
5	5	125	3.5	0.25	
6	6	180	4.2	0.3	
9	9	405	6.3	0.45	
12	12	720	8.4	0.6	
18	18	1,620	12.6	0.9	
24	24	2,880	16.8	1.2	
48	48	6,400	32.6	2.4	360

Note: All values in the table are valid for 20°C and zero contact current unless otherwise specified.

Note: Care shall be taken on the heat generated on PC board when maximum carrying current exceeds 10A.

Please perform the confirmation test with actual conditions

\*: Specified operated values are valid for pulse wave voltage.

## ■ Safety Standards

Type	Compliance	Contact Rating		
		JY-( )HG-K, JY-( )HR-K	JY-( )G-K, JY-( )R-K	JY-( )W-K
UL	UL 508 E56140	5A 250VAC / 30VDC resistive 1/8HP, 125VAC / 250VAC Pilot duty C150, C300	3A 250VAC / 30VDC resistive 1/10HP, 125VAC / 250VAC Pilot duty D150	5A 250VAC / 30VDC resistive 1/8HP, 125VAC /250VAC Pilot duty C300
CSA	C22.2 No. 14 LR 35579			

## ■ Dimensions

- Dimensions

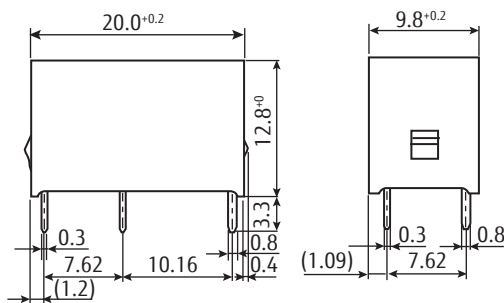

- Schematics (BOTTOM VIEW)

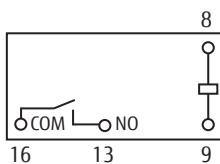

- PC Board Mouting Hole Layout (BOTTOM VIEW)

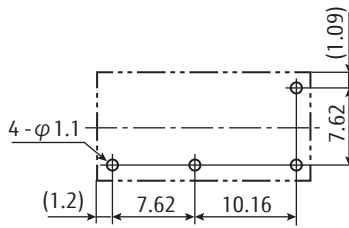

Tolerance of PC board mounting hole layout:  $\pm 0.1$  unless otherwise specified.

( ): Reference value

Unit: mm

## ■ Socket Dimensions

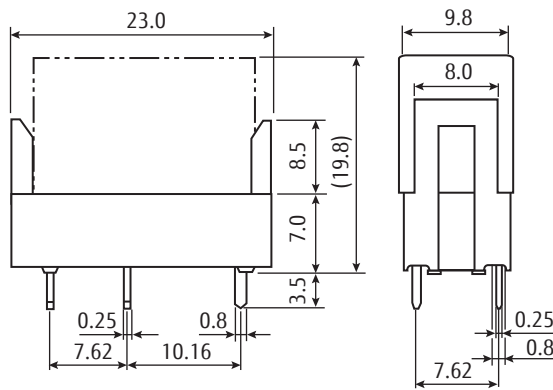

- PC Board Mouting Hole Layout (BOTTOM VIEW)

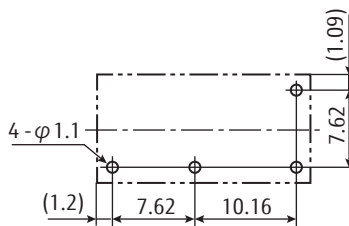

Tolerance of PC board mounting hole layout:  $\pm 0.1$  unless otherwise specified.

( ): Reference value

Unit: mm

Note:

1: Socket ordering code: JK-4N

2: Standard IC socket is not recommended. Please use socket "JK-4N"

## Characteristic Data

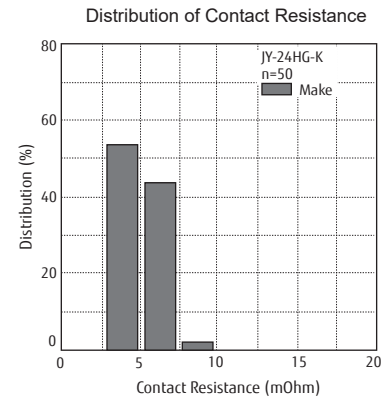
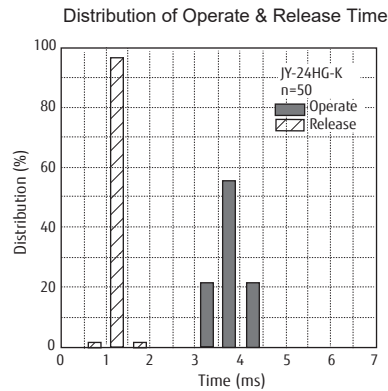
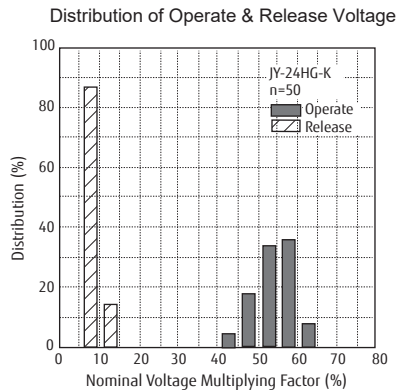
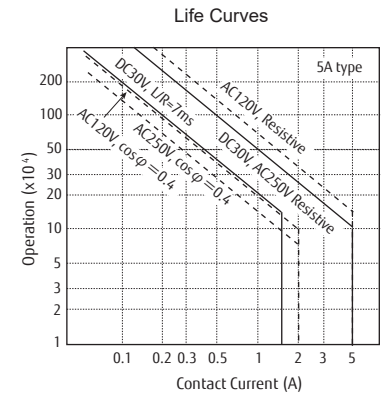
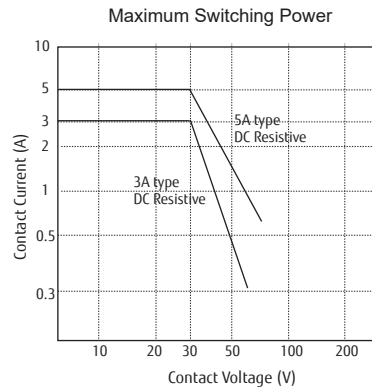
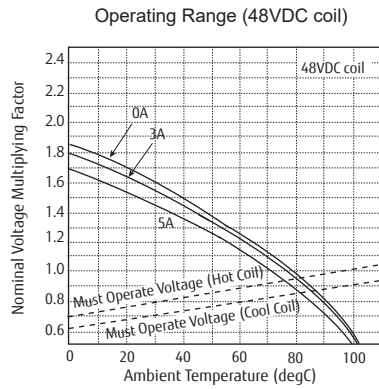
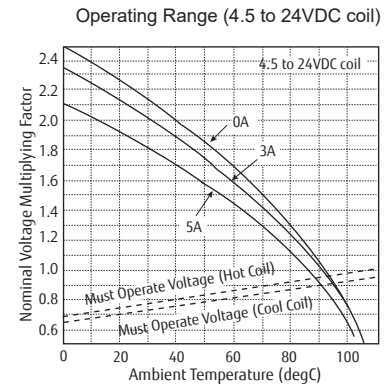
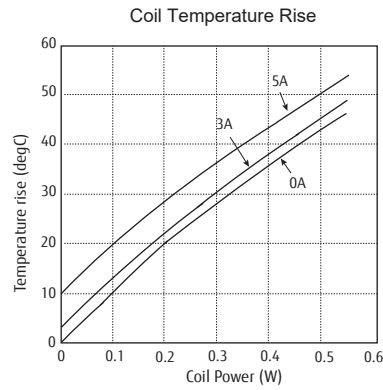
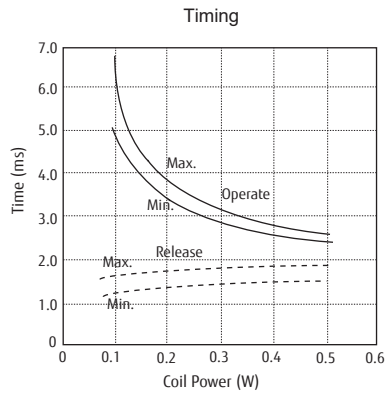

To be discontinued: Relays: July 2024  
 Socket: October 2024

# JY Series

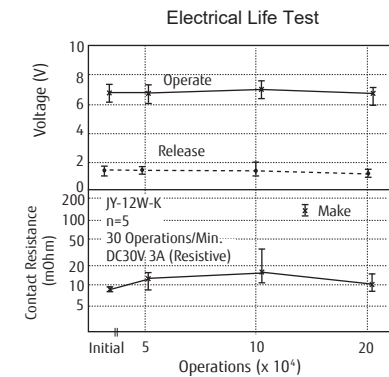
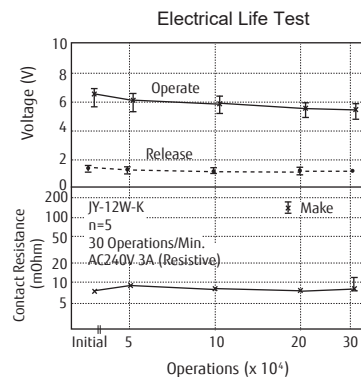
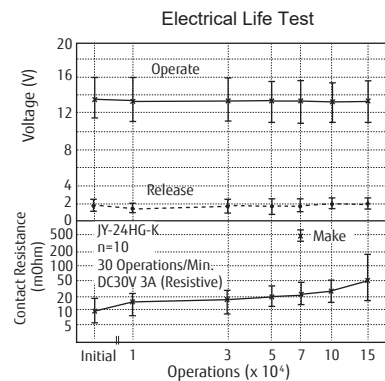
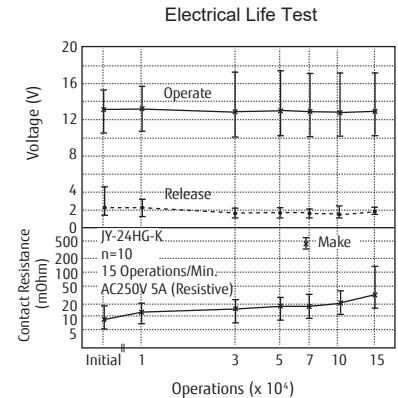
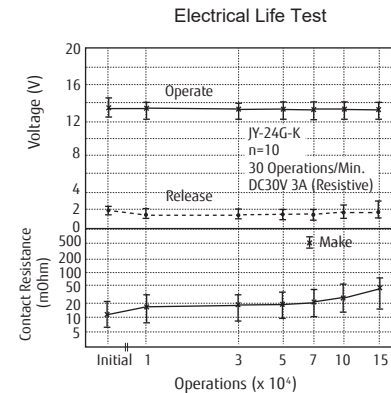
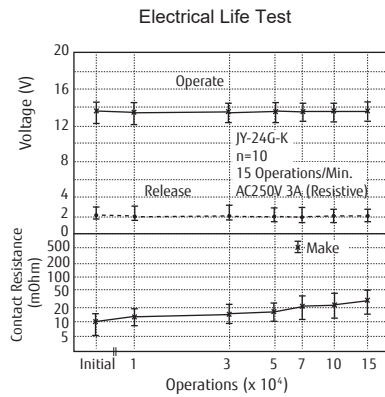
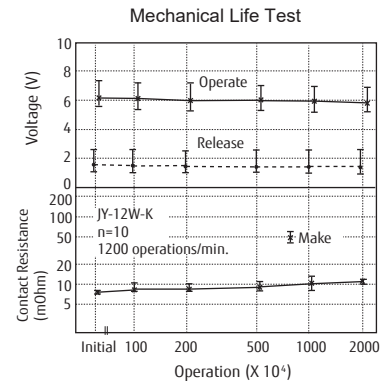
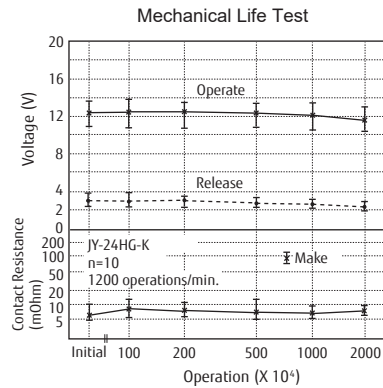
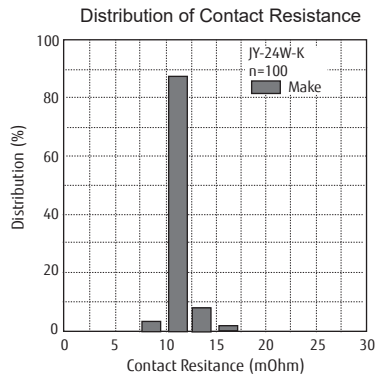

## CAUTIONS

- All values mentioned in this datasheet are provided under ideal conditions. Please perform the confirmation test before actual use.
- Reflow soldering is prohibited.
- Do not use relays in the atmosphere with sulfide gas, chloride gas or nitric oxide. Contact resistance may increase.
- Do not use silicon or silicon-containing product or materials near relays. It may cause contact failure.

## GENERAL INFORMATION

### 1. RoHS Compliance

- All relays produced by FCL Components are compliant with RoHS directive 2011/65/EU, including commission delegated directive 2015/863.

### 2. Recommended lead free solder condition

- Lead free solder plating on relay terminals is Sn-3.0Ag-0.5Cu, unless otherwise specified. This material has been verified to be compatible with PbSn assembly process.
- Recommended solder for assembly: Sn-3.0Ag-0.5Cu.

#### Flow Solder Condition:

Pre-Heating: Maximum 120°C within 90 sec.

Soldering: Dip within 5 sec. at 255°C±5°C solder bath

Relay must be cooled by air immediately after soldering

#### Solder by Soldering Iron:

Soldering Iron: 30-60W

Temperature: Maximum 340-360°C

Duration: Maximum 3 sec.

**We highly recommend that you confirm your actual solder conditions**

### 3. Moisture Sensitivity

- Moisture Sensitivity Level standard is not applicable to electromechanical relays, unless otherwise indicated.

### 4. Tin Whiskers

- Dipped SnAgCu solder is known as presenting a low risk to tin whisker development. No considerable length whisker was found by our in house test.

---

## Contact

### Japan

FCL COMPONENTS LIMITED  
Shinagawa Seaside Park Tower  
12-4, Higashi-shinagawa 4-chome,  
Tokyo 140 0002, Japan  
Tel: +81-3-3450-1682  
Email: fcl-contact@cs.fcl-components.com

### North and South America

FCL COMPONENTS AMERICA, INC.  
2055 Gateway Place Suite 480,  
San Jose, CA 95110 USA  
Tel: +1-408-745-4900  
Email: fcai.components@fcl-components.com

### Europe

FCL COMPONENTS EUROPE B.V.  
Diamantlaan 25  
2132 WV Hoofddorp, Netherlands  
Tel: +31-23-556-0910  
Email: info.fceu@cs.fcl-components.com

### Asia Pacific

FCL COMPONENTS ASIA PTE LTD.  
No. 20 Harbour Drive, #07-01B  
Singapore 117612  
Tel: +65-6375-8560  
Email: fcal@fcl-components.com

### China

FCL COMPONENTS (SHANGHAI) CO., LTD.  
Unit 1105, Central Park - Jing An,  
No.329 Heng Feng Road, Shanghai 200070,  
China  
Tel: +86-21-3253 0998  
Email: fcsh@fcl-components.com

**Web:** [www.fcl-components.com/en/](http://www.fcl-components.com/en/)

---

© 2024 FCL Components Limited. All rights reserved. All trademarks or registered trademarks are the property of their respective owners.

FCL Products are intended for general use, including without limitation, in personal, household and office environments, in buildings and for ordinary use in the industry. FCL Products are not intended to be used in applications where extremely high safety is required ("High Safety Required Applications"), such as, but not limited to, applications in nuclear facilities, in aircraft automatic flight control, in air traffic control, in mass transit system control, in missile launch system, in weapon systems, in medical equipment for life support or any application involving a direct serious risk of physical injury or death.

Please do not use FCL Products without securing the sufficient safety and reliability required for the High Safety Required Applications. In addition, FCL shall not be liable against the customer and/or any third party for any claims or damages arising in connection with the use of FCL Products in the High Safety Required Applications.

FCL warrants that its Products, if properly used and services, will conform to their specification and will be free from defects in material and workmanship for twelve months from delivery.

The implied warranties of merchantability and fitness for a particular purpose and all other warranties, representations and conditions, express or implied by statute, trade usage or otherwise, except as set forth in this warranty, are excluded and shall not apply to the Products delivered.

The contents, data and information in this datasheet are provided by FCL Components Limited as a service only to its user and only for general information purposes. The use of the contents, data and information provided in this datasheet is at the users' own risk. FCL has assembled this datasheet with care and will endeavor to keep the contents, data and information correct, accurate, comprehensive, complete and up to date.

FCL Components Limited and affiliated companies do however not accept any responsibility or liability on their behalf, nor on behalf of its employees, for any loss or damage, direct, indirect or consequential, with respect to this datasheet, its contents, data, and information and related graphics and the correctness, reliability, accuracy, comprehensiveness, usefulness, availability and completeness thereof. Nor do FCL Components Limited and affiliated companies accept on their behalf, nor on behalf of its employees, any responsibility or liability with respect to these datasheets, its contents, data, information and related graphics and the correctness, reliability, accuracy, comprehensiveness, usefulness, availability and completeness thereof. Rev. February 1, 2024.

---