

COMPACT POWER TWIN RELAY

for automotive applications

1 POLE x 2 - 25A (for 12V car battery)

FTR-P4 Series

■ FEATURES

- Compact for high density packaging
- High contact capacity with proven contact material
(100,000 operations, 14 V, 25 A)
- Coil power savings
(600mW nominal achieved with state-of-the-art magnetic analysis/design)
- Ease of PCB layout
(all terminals on perimeter, coil and contact terminals separated)
- Pin compatible with low acoustic noise relay, FTR-P2
- Packaging for auto-insertion
(tube packing, 30 relays/tube)
- Application examples: power window, power seat, tilt steering, door lock, sun roof, retractable antenna
- RoHS compliant
Please see page 7 for more information



■ PARTNUMBER INFORMATION

[Example] FTR-P4 C N 012 W1
 (a) (b) (c) (d) (e)

(a)	Relay type	FTR-P4	: FTR-P4 Series
(b)	Contact configuration	C	: 1 form C X 2 (H-Bridge)
(c)	Contact gap	N	: 0.25mm gap
(d)	Coil rated voltage	012	: 9.....12 VDC Coil rating table at page 3
(e)	Contact material	W1	: Silver-tin oxide indium

Actual marking does not carry the type name: "FTR"

E.g.: Ordering code: FTR-P4CN012W1 Actual marking: P4CN012W1

FTR-P4 SERIES

■ SPECIFICATION

Item	FTR-P4		
Contact Data	Configuration	1 form C x 2 (H-Bridge)	
	Material	Silver-tin oxide indium	
	Contact path voltage drop	Max. 100mV at 1A, 12VDC	
	Contact rating	25A at 14VDC (locked motor load)	
	Max. carrying current	25A/1 hour (25 °C, 100% rated coil voltage at N.O. side, de-energized at N.C. side)	
	Max. switching power	35A 16VDC (reference)	
	Min. switching load *	6 VDC, 1A (reference)	
Life	Mechanical	Min. 10 x 10 ⁶ operations	
	Electrical	Min. 100 x 10 ³ operations, 14VDC, 25A (locked motor load) (1 operation = 1 forward and 1 reverse)	
Coil Data	Operating temperature range	-40 °C to +85 °C (no frost)	
	Storage temperature range	-40 °C to +100 °C (no frost)	
Timing Data	Operate (at nominal voltage)	Max. 10 ms (without bounce)	
	Release (at nominal voltage)	Max. 5 ms (without bounce, no diode) Max. 15 ms (without bounce, with diode)	
Insulation	Resistance (initial)	100M Ω at 500VAC	
	Dielectric withstanding voltage (initial)	500VAC	
Other	Vibration resistance	Misoperation	10 to 200Hz, acceleration 44m/s ² (4.5G), constant acceleration
		Endurance	10 to 200Hz, acceleration 44m/s ² (4.5G), constant acceleration
	Shock	Operational	100 m/s ² minimum (11±1ms)
		Withstand, no damage	1,000m/s ² minimum (6±1ms)
	Weight	Approximately 10 g	

* Minimum switching loads mentioned above are reference values. Please perform the confirmation test with actual load before production since reference values may vary according to switching frequencies, environmental conditions and expected reliability levels.

Note:

Care shall be taken on the heat generated on PC board when maximum carrying current exceeds 10A. Please perform the confirmation test with actual conditions.

FTR-P4 SERIES

■ COIL RATING

P4 Series (0.25mm contact gap)

Coil Code	Rated Coil Voltage (VDC)	Coil Resistance +/- 10% (Ohm)	Must Operate Voltage (VDC) *	Must Release Voltage (VDC) *
009	9	135	5.5 (at 20 °C)	0.7 (at 20 °C)
			6.9 (at 85 °C)	0.9 (at 85 °C)
010	10	167	6.3 (at 20 °C)	0.8 (at 20 °C)
			7.9 (at 85 °C)	1.0 (at 85 °C)
012	12	240	7.3 (at 20 °C)	1.0 (at 20 °C)
			9.2 (at 85 °C)	1.3 (at 85 °C)

■ CHARACTERISTIC DATA

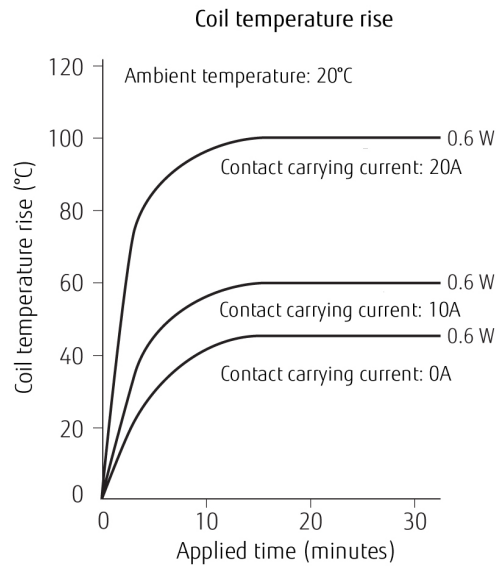
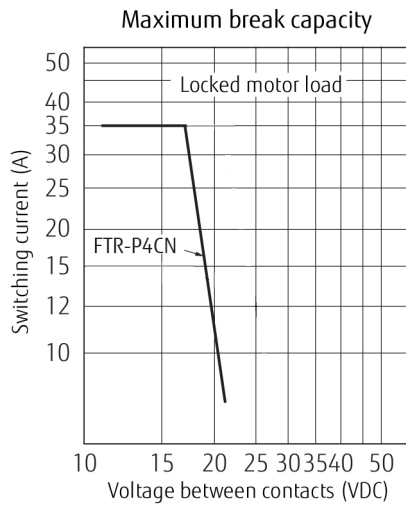

FTR-P4 SERIES

Life test (examples)

Test condition
 25A, 14VDC
 motor lock
 100,000 operations min.
 0.25 seconds ON
 9.75 seconds OFF

Test circuit

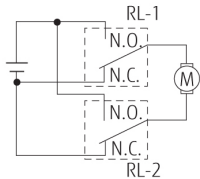

Current wave form

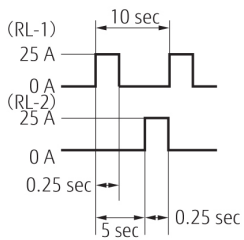

Test condition
 Inrush current 17A, 14VDC
 motor free
 300,000 operations min.
 0.25 seconds ON
 9.75 seconds OFF

Test circuit

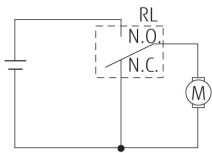

Current wave form

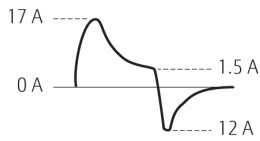

• Shift of pick-up drop-out voltage

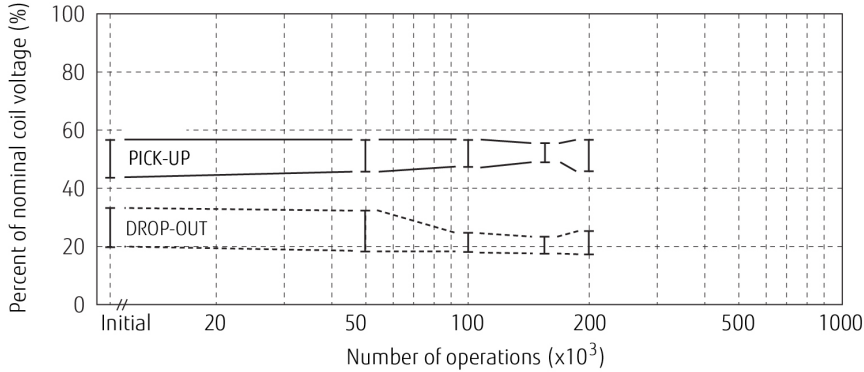

• Change of contact resistance

(Measured at DC6 V, 1A wet)

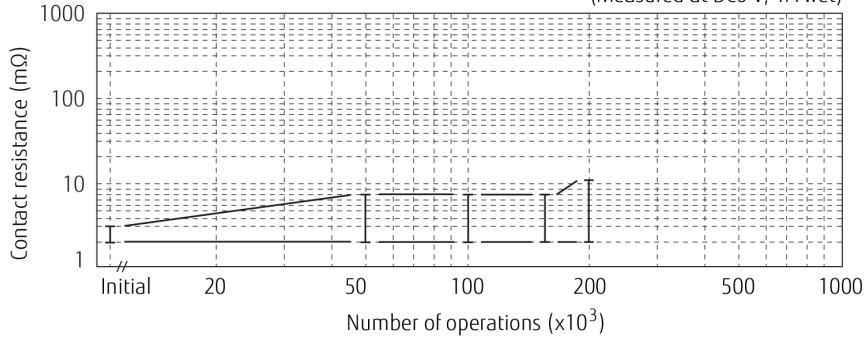

• Shift of pick-up drop-out voltage

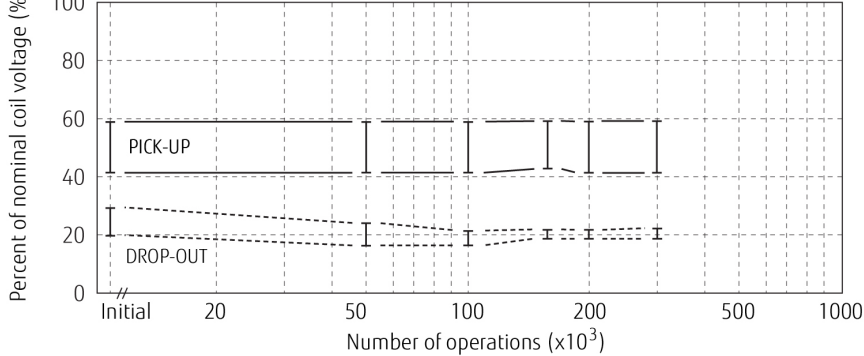

• Change of contact resistance

(Measured at DC6 V, 1A wet)

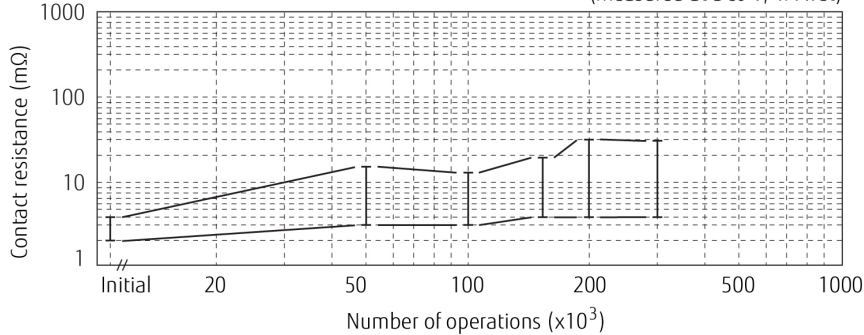

FTR-P4 SERIES

Vibration resistance characteristics

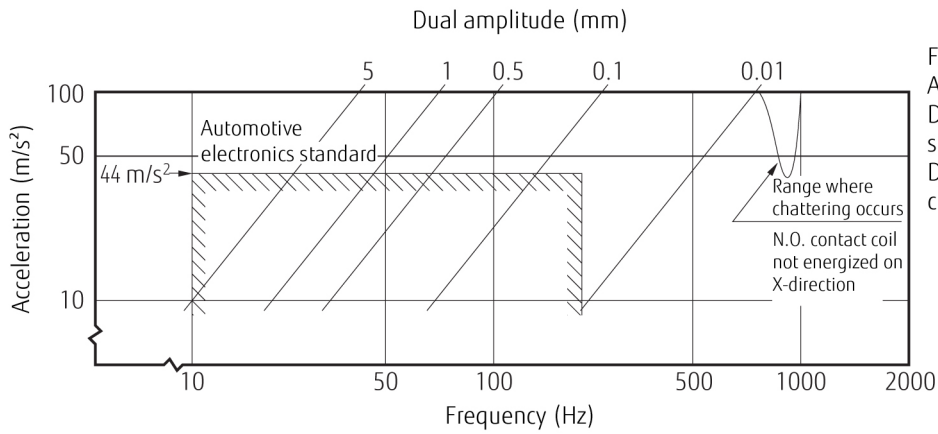

Frequency: 10~2000 Hz
 Acceleration: 100 m/s^2 max.
 Direction of vibration;
 see diagram below
 Detection level:
 chatter > 1ms

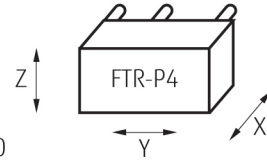

Shock resistance characteristics

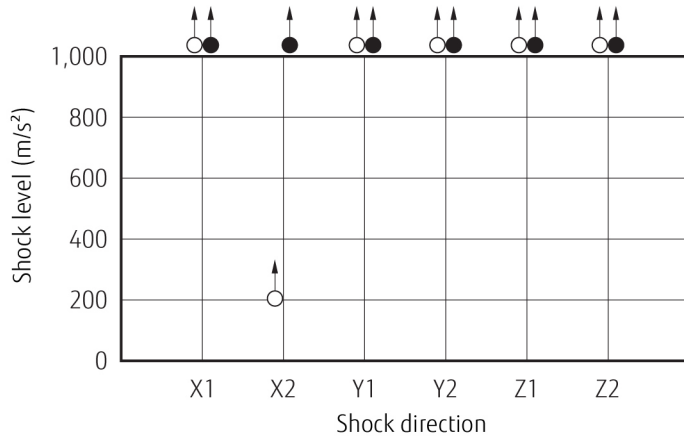

Shock application time: 6 ± 1 ms, half-sine wave
 Test material: coil energized and de-energized
 Shock direction: see diagram below
 Detection level: chatter > 1ms

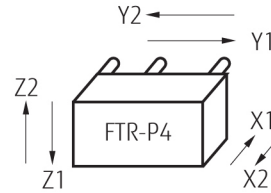

○ : break contact (coil de-energized)
 ● : make contact (coil energized)

Operating coil voltage range

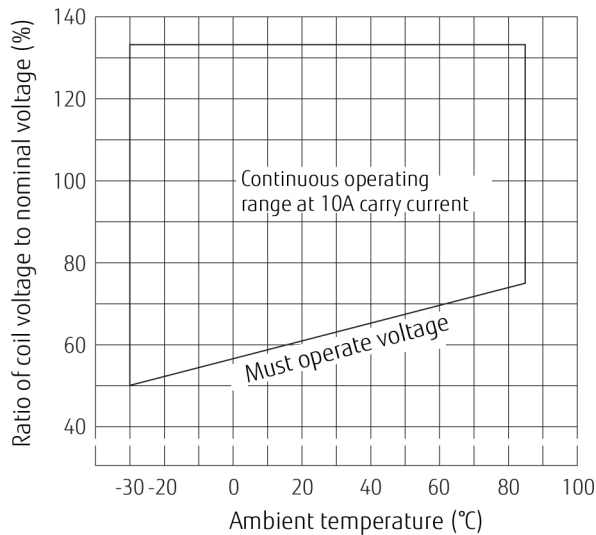

FTR-P4 SERIES

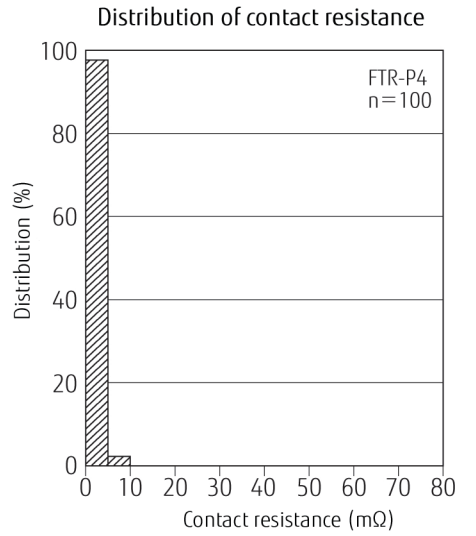
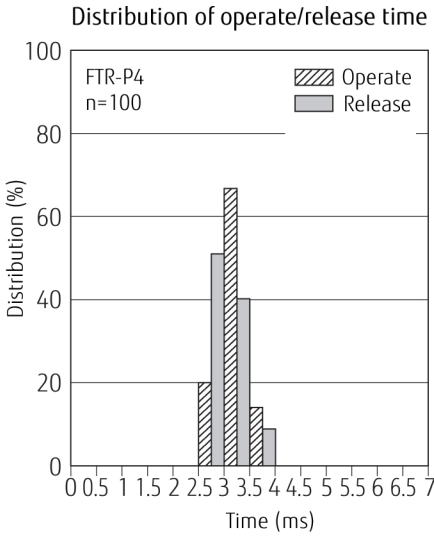
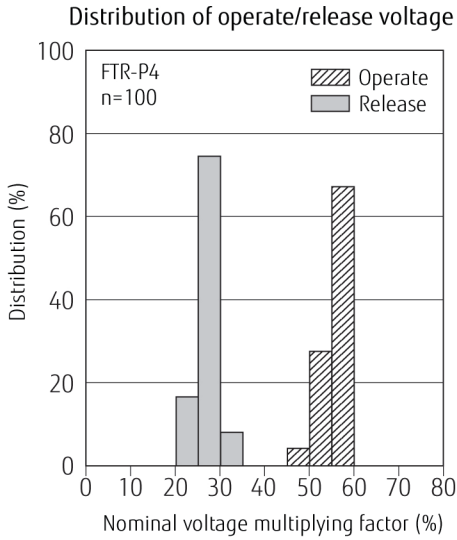

DIMENSIONS

- Dimensions

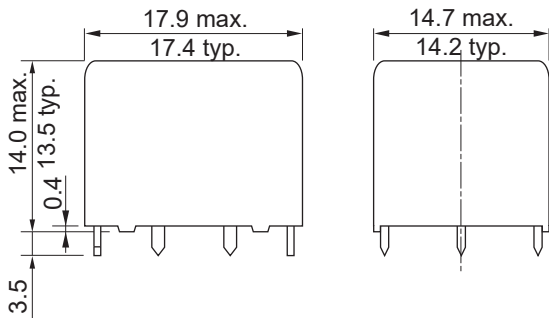

- Schematics (BOTTOM VIEW)

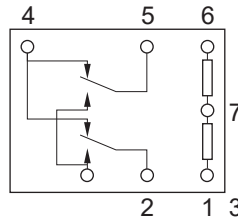

- PC board mounting hole layout (BOTTOM VIEW)

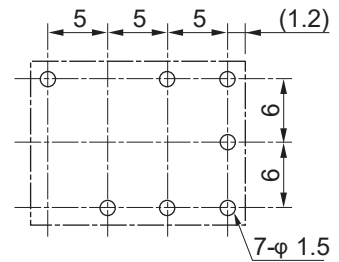

* Dimensions of the terminals do not include thickness of pre solder.
 * This datasheet provide only + tolerance for outer dimensions.
 Please ask for specification in case you need other tolerances.

Tolerance of PC board mounting hole layout : ± 0.1 unless otherwise specified.

(): Reference
 Unit: mm

CAUTIONS

- All values mentioned in this datasheet are provided under ideal conditions. Please perform the confirmation test before actual use.
- Reflow soldering is prohibited.
- Do not use relays in the atmosphere with sulfide gas, chloride gas or nitric oxide. Contact resistance may increase.
- Do not use silicon or silicon-containing product or materials near relays. It may cause contact failure.

GENERAL INFORMATION

1. ROHS Compliance

- All relays produced by FCL Components are compliant with RoHS directive 2011/65/EU, including commission delegated directive 2015/863.

2. Recommended lead free solder condition

- Lead free solder plating on relay terminals is Sn-3.0Ag-0.5Cu, unless otherwise specified. This material has been verified to be compatible with PbSn assembly process.
- Recommended solder for assembly: Sn-3.0Ag-0.5Cu.

Flow Solder Condition:

Pre-Heating: Maximum 120°C within 90 sec.

Soldering: Eip within 5 sec. at 255°C±5°C solder bath

Relay must be cooled by air immediately after soldering

Solder by Soldering Iron:

Soldering Iron: 30-60W

Temperature: Maximum 340-360°C

Duration: Maximum 3 sec.

We highly recommend that you confirm your actual solder conditions

3. Moisture Sensitivity

- Moisture Sensitivity Level standard is not applicable to electromechanical relays, unless otherwise indicated.

4. Tin Whiskers

- Dipped SnAgCu solder is known as presenting a low risk to tin whisker development. No considerable length whisker was found by our in house test.

Contact

Japan

FCL COMPONENTS LIMITED
Shinagawa Seaside Park Tower
12-4, Higashi-shinagawa 4-chome,
Tokyo 140 0002, Japan
Tel: +81-3-3450-1682
Email: fcl-contact@cs.fcl-components.com

North and South America

FCL COMPONENTS AMERICA, INC.
2055 Gateway Place Suite 480,
San Jose, CA 95110 USA
Tel: +1-408-745-4900
Email: fcai.components@fcl-components.com

Europe

FCL COMPONENTS EUROPE B.V.
Diamantlaan 25
2132 WV Hoofddorp, Netherlands
Tel: +31-23-556-0910
Email: info.fceu@cs.fcl-components.com

Asia Pacific

FCL COMPONENTS ASIA PTE LTD.
No. 20 Harbour Drive, #07-01B
Singapore 117612
Tel: +65-6375-8560
Email: fcalfcl-components.com

China

FCL COMPONENTS (SHANGHAI) CO., LTD.
Unit 1105, Central Park - Jing An,
No.329 Heng Feng Road, Shanghai 200070,
China
Tel: +86-21-3253 0998
Email: fcsh@fcl-components.com

Web: www.fcl-components.com/en/

© 2024 FCL Components Limited. All rights reserved. All trademarks or registered trademarks are the property of their respective owners.

FCL Products are intended for general use, including without limitation, in personal, household and office environments, in buildings and for ordinary use in the industry. FCL Products are not intended to be used in applications where extremely high safety is required ("High Safety Required Applications"), such as, but not limited to, applications in nuclear facilities, in aircraft automatic flight control, in air traffic control, in mass transit system control, in missile launch system, in weapon systems, in medical equipment for life support or any application involving a direct serious risk of physical injury or death.

Please do not use FCL Products without securing the sufficient safety and reliability required for the High Safety Required Applications. In addition, FCL shall not be liable against the customer and/or any third party for any claims or damages arising in connection with the use of FCL Products in the High Safety Required Applications.

FCL warrants that its Products, if properly used and services, will conform to their specification and will be free from defects in material and workmanship for twelve months from delivery.

The implied warranties of merchantability and fitness for a particular purpose and all other warranties, representations and conditions, express or implied by statute, trade usage or otherwise, except as set forth in this warranty, are excluded and shall not apply to the Products delivered.

The contents, data and information in this datasheet are provided by FCL Components Limited as a service only to its user and only for general information purposes. The use of the contents, data and information provided in this datasheet is at the users' own risk.

FCL has assembled this datasheet with care and will endeavor to keep the contents, data and information correct, accurate, comprehensive, complete and up to date.

FCL Components Limited and affiliated companies do however not accept any responsibility or liability on their behalf, nor on behalf of its employees, for any loss or damage, direct, indirect or consequential, with respect to this datasheet, its contents, data, and information and related graphics and the correctness, reliability, accuracy, comprehensiveness, usefulness, availability and completeness thereof.

Nor do FCL Components Limited and affiliated companies accept on their behalf, nor on behalf of its employees, any responsibility or liability with respect to these datasheets, its contents, data, information and related graphics and the correctness, reliability, accuracy, comprehensiveness, usefulness, availability and completeness thereof. Rev. February 1, 2024.
