

# HIGH VOLTAGE DC SWITCHING RELAY

## MAX. 1,000VDC BREAK HIGH CAPACITY DC POWER RELAY

### FTR-E1 SERIES

ROHS COMPLIANT



#### ■ FEATURES

- 20/30A 450VDC, 20A 800VDC and 10A 1,000VDC high voltage DC load switching.
- Non polarized contacts. Switchable for charge/discharge circuit.
- Low coil power consumption (0.9W at coil rated voltage)
- High insulation.
  - Between coil and contact: 5,000VAC, 1 minute.
  - Between open contact: 2,500VDC, 1 minute.
- cULus recognized types are available.
- Plastic material: UL flammability 94V-0.
- Plastic sealed.



#### ■ APPLICATIONS

- On board electrical vehicles charger system and plug-in hybrid vehicles
- String disconnecting of photovoltaics systems
- Charge and discharge of power storage system
- High voltage DC load control system
- Electric vehicles pre-charge
- Vehicle to Home

#### ■ PART NUMBERS

[Example] FTR-E1   A   A   012   Y   -   MF  
 (a)   (b)   (c)   (d)   (e)   (f)

(a)	Relay type	FTR-E1 series
(b)	Contact configuration	A : 1a (1 Form X)
(c)	Power consumption	A : Standard (900mW)
(d)	Nominal coil voltage	12 : 12VDC 24 : 24VDC
(e)	Contact material	Y : Silver alloy
(f)	Special type	MF : Standard (20A) GR : cULus recognized (20A) HA : cULus recognized (30A)

Note: The designation name is stamped on the top of the relay case as follows:

Example: Ordering part number: FTR-E1AA012Y-MF Stamped on part number: E1AA012Y-MF

## ■ SPECIFICATIONS

Item		Specifications		Remarks/Conditions
		20A type (-MF, -GR)	30A type (-HA)	
Contact Data	Configuration	1a (1 Form X)		
	Material	Silver alloy		
	Construction	Single contact		
	Contact rating	20A, 450VDC 20A, 800VDC 10A, 1,000VDC	30A, 450VDC 20A, 800VDC 10A, 1,000VDC	Resistive
	Voltage drop	Max. 0.5V		At 20A
	Continuous carrying current	25A (85°C, cable size 5.5mm <sup>2</sup> ) 30A (70°C, cable size 8mm <sup>2</sup> ) 40A (40°C, cable size 8mm <sup>2</sup> )		Please refer to characteristic data
	Max. carrying current	40A / 1 hour (85°C, cable size 8mm <sup>2</sup> )		
	Min. switching load <sup>*1</sup>	1A 6VDC		Reference
Coil	Rated power consumption	900mW		At 20°C
	Operate power consumption	324mW		At 20°C
	Operating temperature range	-40°C to +85°C		No frost
Time	Operate	Max. 30ms (without bounce)		At 20°C, nominal voltage
	Release	Max. 10ms (without diode, without bounce)		At 20°C, nominal voltage
Life	Mechanical	1 x 10 <sup>6</sup> operations		18,000 operations / hour
		75 x 10 <sup>3</sup> operations		10A, 450VDC resistive, with suppression device <sup>*2</sup>
	Electrical (resistive)	10 x 10 <sup>3</sup> operations		20A, 450VDC resistive, with suppression device <sup>*2</sup>
		-	5 x 10 <sup>3</sup> operations	30A, 450VDC resistive, with suppression device <sup>*2</sup>
		10 operations		20A, 800VDC resistive, with suppression device <sup>*2</sup>
		50 operations		10A, 1,000VDC resistive, with suppression devices <sup>*2</sup>
		200 operations		5A, 1,000VDC resistive, with suppression devices <sup>*2</sup>
		100 x 10 <sup>3</sup> operations		20A, 450VDC inrush only (without break)
100 x 10 <sup>3</sup> operations		20A, 800VDC inrush only (without break)		
Insulation	Insulation resistance		1,000MΩ	At 1,000VDC
	Dielectric withstanding voltage	Open contacts	2,500VAC(50/60Hz), 1 minute	
		Coil to contacts	5,000VAC(50/60Hz), 1 minute	
Others	Vibration resistance	Misoperation	5 to 200Hz, 45m/s <sup>2</sup> , constant acceleration	
		Endurance	to 200Hz, 45m/s <sup>2</sup> , constant acceleration	
	Shock resistance	Misoperation	300m/s <sup>2</sup> (11±1ms, contact ON) 200m/s <sup>2</sup> (11±1ms, contact OFF)	
		Endurance	1,000m/s <sup>2</sup> (6±1ms)	
	Dimensions / Weight		28.3×43.6×36.8 mm / approx. 75g	

Note: Electrical characteristics mentioned above are the values at JIS standard condition (temperature 15 to 35degC, relative humidity 25 to 75%, atmospheric pressure 86k to 106kPa) unless otherwise specified.

Note: Care shall be taken on the heat generated on PC board when maximum carrying current exceeds 10A. Please perform the confirmation test with actual conditions.

\*1: Minimum switching loads mentioned above are reference values. Please perform the confirmation test with actual load before production since reference values may vary according to switching frequencies, environmental conditions and expected reliability levels.

\*2: Electrical life at resistive load mentioned above are the values when a varistor or zener diode or zener diode+diode is used as coil suppression device. Using protection device other than these, the contact life expectancy may decrease drastically. When using a varistor as a suppression device, varistor voltage shall be approximately twice the voltage applied to the coil and connect it in parallel with the coil. When using a zener diode or zener diode+diode as a suppression device, please refer to the CIRCUIT DIAGRAM WHEN USING ZENER DIODE.

## ■ COIL DATA

Coil Code	Nominal Coil Voltage (VDC)	Coil Resistance ±10% (Ω)	Must Operate Voltage <sup>1</sup> (VDC)	Must Release Voltage <sup>1</sup> (VDC)
012	12	160	7.2 (at 20°C) 9.0 (at 85°C)	1.0 (at 20°C) 1.3 (at 85°C)
024	24	640	14.4 (at 20°C) 18.0 (at 85°C)	2.0 (at 20°C) 2.6 (at 85°C)

Note: All values in the table are valid at 20°C and zero contact current unless otherwise specified.

Note: Coil polarity must be applied as specified in schematics.

\*1: Specified operate values are valid for pulse wave voltage.

## ■ SAFETY STANDARDS

Type	Compliance	Contact Rating
cULus	UL508 C22.2 No.14-13 (File No. E63615)	<b>[FTR-E1AA***Y-GR]</b> 10A, 450VDC (resistive) 85°C 20A, 450VDC (resistive) 85°C <b>[FTR-E1AA***Y-HA]</b> 10A, 450VDC (resistive) 85°C 20A, 450VDC (resistive) 85°C 30A, 450VDC (resistive) 85°C

## ■ PART NUMBER LIST

Part Number	Nominal Coil Voltage	Contact Rating	Safety Standard
FTR-E1AA012Y-MF	12VDC	20A 450VDC, 20A 800VDC, 10A 1,000VDC	-
FTR-E1AA012Y-GR		20A 450VDC, 20A 800VDC, 10A 1,000VDC	cULus (450VDC only)
FTR-E1AA012Y-HA		30A 450VDC, 20A 800VDC, 10A 1,000VDC	cULus (450VDC only)
FTR-E1AA024Y-MF	24VDC	20A 450VDC, 20A 800VDC, 10A 1,000VDC	-
FTR-E1AA024Y-GR		20A 450VDC, 20A 800VDC, 10A 1,000VDC	cULus (450VDC only)
FTR-E1AA024Y-HA		30A 450VDC, 20A 800VDC, 10A 1,000VDC	cULus (450VDC only)

## ■ DIMENSIONS

### • Dimensions

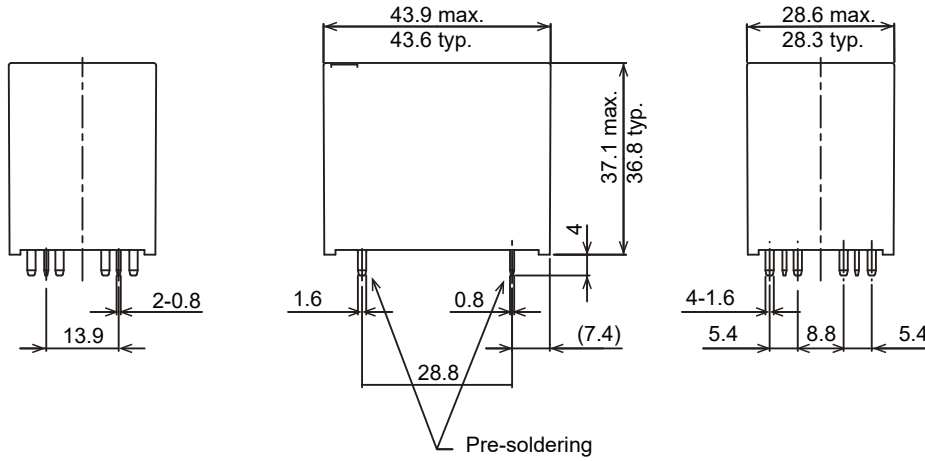

Note: Dimensions of the terminals do not include thickness of pre-soldering.

### • Schematics (BOTTOM VIEW)

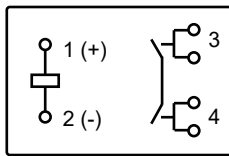

### • PC Board Mounting Hole Layout (BOTTOM VIEW)

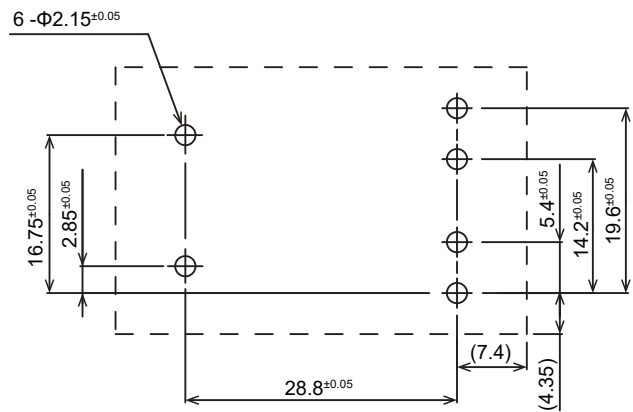

( ): Reference Unit: mm

## CHARACTERISTIC DATA

(Characteristic data is not guaranteed value but measured values of samples from production line.)

Distribution of operate/release voltage

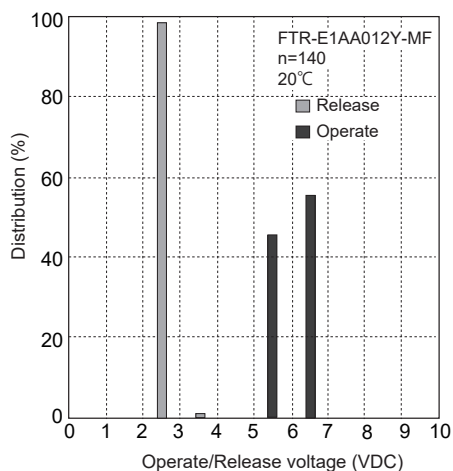

Distribution of voltage drop

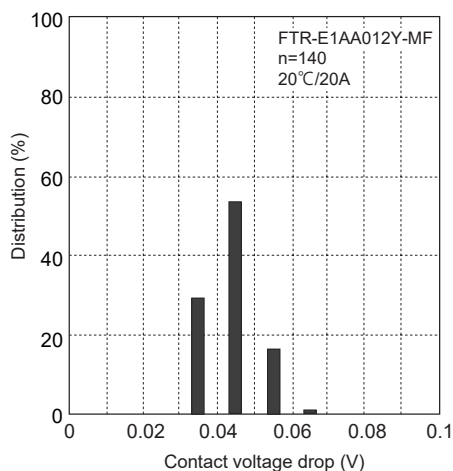

Distribution of operate time

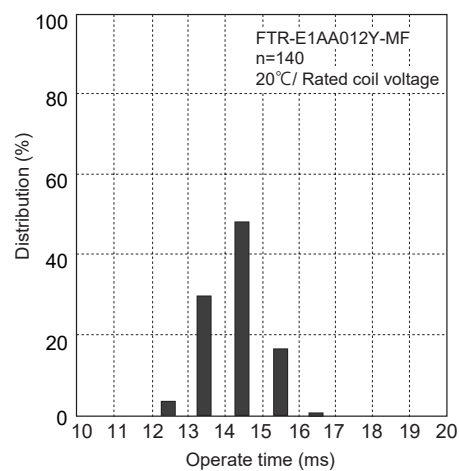

Distribution of release time

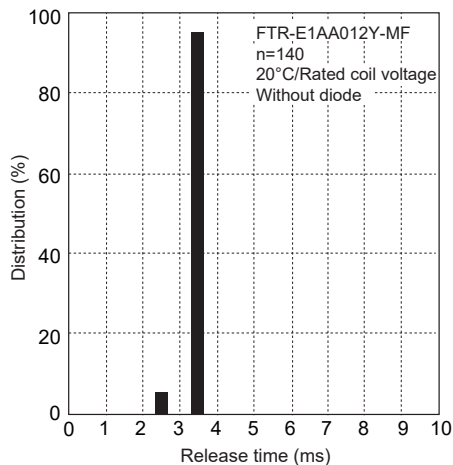

Coil temperature rise

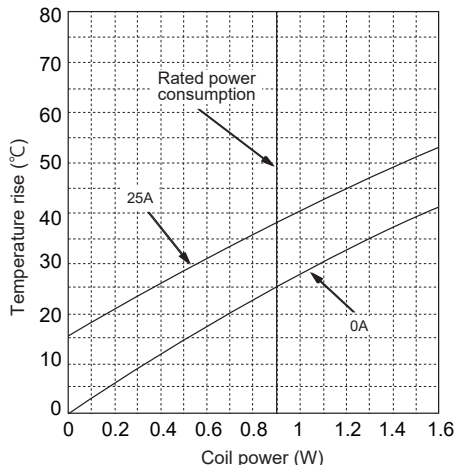

Operating range

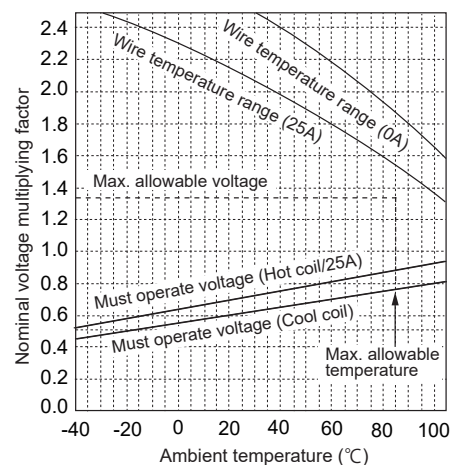

Ambient temperature - contact carrying current

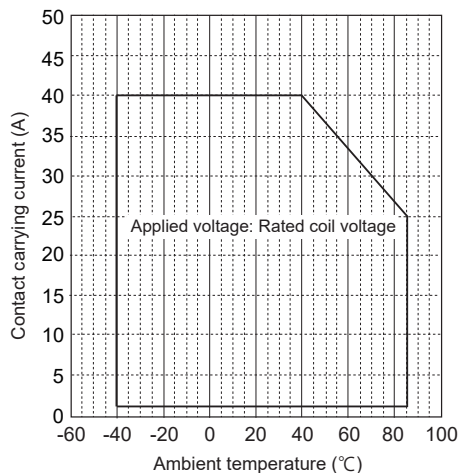

Switching life curve

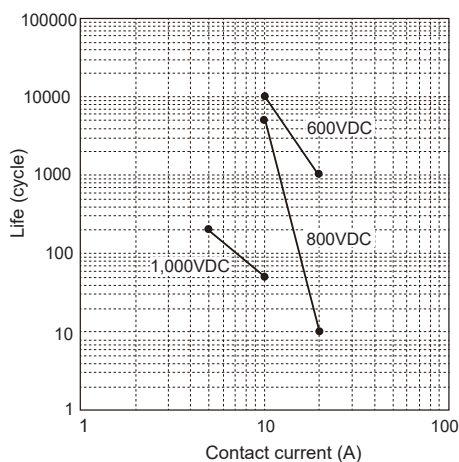

## CHARACTERISTIC DATA

(Characteristic data is not guaranteed value but measured values of samples from production line.)

Vibration resistance characteristics

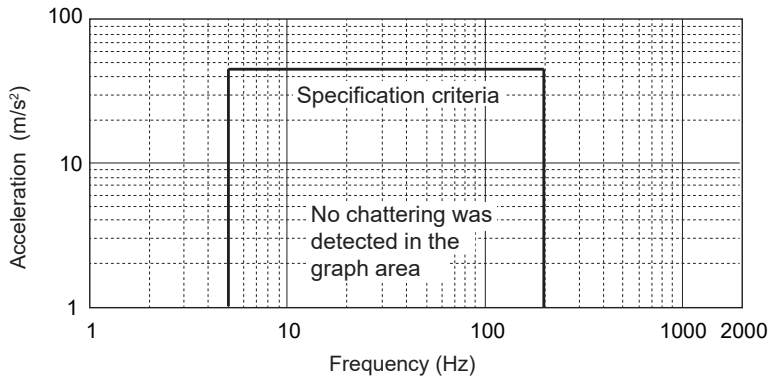

Test material: coil energized and de-energized  
 Direction of vibration: see diagram below  
 Detection level: chatter >1 ms

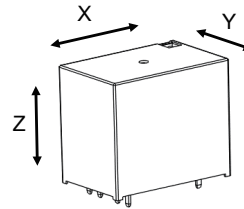

Shock resistance characteristics

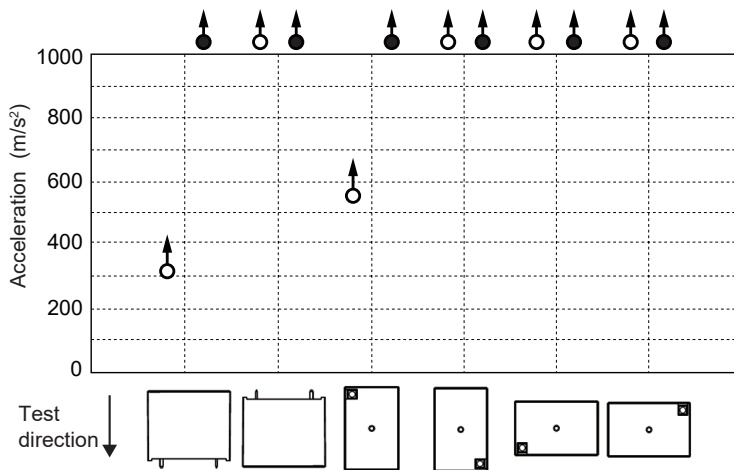

Test material: coil energized and de-energized  
 Shock duration: 11ms (490m/s<sup>2</sup> or less)  
 6ms (more than 490m/s<sup>2</sup>)  
 Test direction: see diagram under the graph  
 Detection level: chatter > 1ms

○ : Coil de-energized  
 ● : Coil energized

## ■ CIRCUIT DIAGRAM WHEN USING ZENER DIODE (Refer to \*2 on page 2)

1. Using zener diode + diode

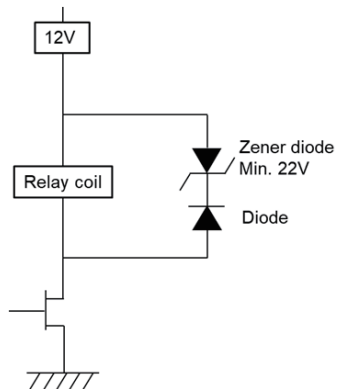

■ Nominal coil voltage: 24V

1. Using zener diode + diode

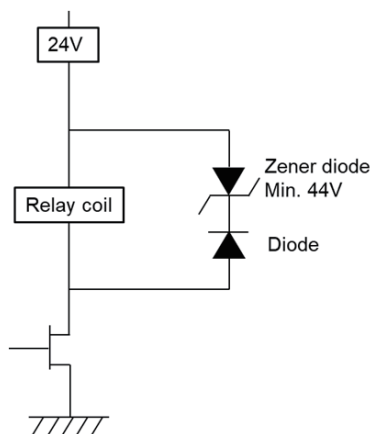

1. Using zener diode

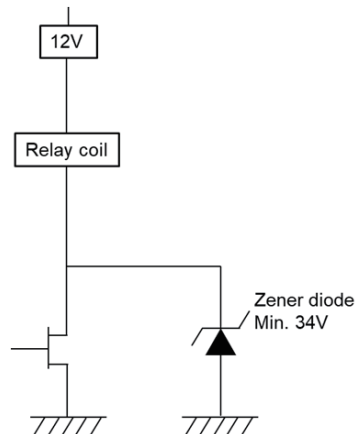

2. Using zener diode

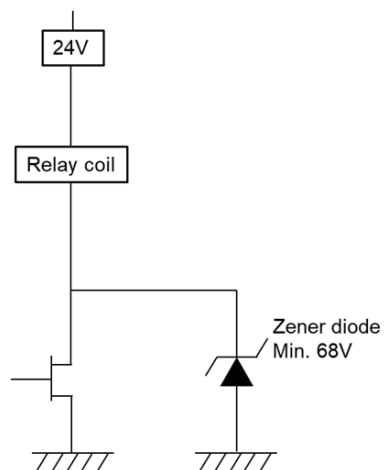

## CAUTIONS

- All values mentioned in this datasheet are provided under ideal conditions. Please perform the confirmation test before actual use.
- Reflow soldering is prohibited.
- Do not use relays in the atmosphere with sulfide gas, chloride gas or nitric oxide. Contact resistance may increase.
- Do not use silicon or silicon-containing product or materials near relays. It may cause contact failure.
- Please connect relay coils according to specified polarity.

### Cautions for high voltage DC switching relays

- There is a possibility that the relay is not able to switch off the load at high voltage DC load. Fail safe circuit must be provided to prevent injury, fire or other harms resulting from failure occurred on relays.
- Relays are periodic maintenance parts. Do not exceed the specified life time and/or switching conditions.

## GENERAL INFORMATION

### 1. ROHS Compliance

- All relays produced by FCL Components are compliant with RoHS directive 2011/65/EU, including commission delegated directive 2015/863.

### 2. Recommended lead free solder condition

- Lead free solder plating on relay terminals is Sn-3.0Ag-0.5Cu, unless otherwise specified. This material has been verified to be compatible with PbSn assembly process.
- Recommended solder for assembly: Sn-3.0Ag-0.5Cu.

#### Flow Solder Condition:

Pre-Heating: Maximum 120°C  
within 90 sec.  
Soldering: Dip within 5 sec. at 255°C±5°C solder bath

Relay must be cooled by air immediately after soldering

#### Solder by Soldering Iron:

Soldering Iron: 30-60W  
Temperature: maximum 340-360°C  
Duration: maximum 3 sec.

**We highly recommend that you confirm your actual solder conditions**

### 3. Moisture Sensitivity

- Moisture Sensitivity Level standard is not applicable to electromechanical relays, unless otherwise indicated.

### 4. Tin Whiskers

- Dipped SnAgCu solder is known as presenting a low risk to tin whisker development. No considerable length whisker was found by our in house test.



## Contact

### Japan

FCL COMPONENTS LIMITED  
Shinagawa Seaside Park Tower  
12-4, Higashi-shinagawa 4-chome,  
Tokyo 140 0002, Japan  
Tel: +81-3-3450-1682  
Email: fcl-contact@cs.fcl-components.com

### North and South America

FCL COMPONENTS AMERICA, INC.  
2055 Gateway Place Suite 480,  
San Jose, CA 95110 USA  
Tel: +1-408-745-4900  
Email: fcmai.components@fcl-components.com

### Europe

FCL COMPONENTS EUROPE B.V.  
Diamantlaan 25  
2132 WV Hoofddorp, Netherlands  
Tel: +31-23-556-0910  
Email: info@fcl-components.eu

### Asia Pacific

FCL COMPONENTS ASIA PTE LTD.  
51 Changi Business Park Central 2, #06-07  
The Signature Singapore 486066  
Tel: +65-6375-8560  
Email: fcal@fcl-components.com

### China

FCL COMPONENTS (SHANGHAI) CO.,LTD.  
Unit 1105, Central Park - Jing An,  
No.329 Heng Feng Road, Shanghai  
200070, China  
Tel: +86-21-3253 0998  
Email: fcsh@fcl-components.com

### Hong Kong

FCL COMPONENTS HONG KONG CO.,  
LIMITED  
Unit 2313, Seapower Tower, Concordia  
Plaza, No.1 Science Museum Road,  
TST, Kowloon, Hong Kong  
Tel: +852-2881-8495  
Email: fcal@fcl-components.com

Web: [www.fcl-components.com/en/](http://www.fcl-components.com/en/)

© 2025 FCL Components Limited. All rights reserved. All trademarks or registered trademarks are the property of their respective owners.

FCL Components Products are intended for general use, including without limitation, in personal, household and office environments, in buildings and for ordinary use in the industry. FCL Components Products are not intended to be used in applications where extremely high safety is required ("High Safety Required Applications"), such as, but not limited to, applications in nuclear facilities, in aircraft automatic flight control, in air traffic control, in mass transit system control, in missile launch system, in weapon systems, in medical equipment for life support or any application involving a direct serious risk of physical injury or death.

Please do not use FCL Components Products without securing the sufficient safety and reliability required for the High Safety Required Applications.

In addition, FCL Components shall not be liable against the customer and/or any third party for any claims or damages arising in connection with the use of FCL Components Products in the High Safety Required Applications.

FCL Components warrants that its Products, if properly used and services, will conform to their specification and will be free from defects in material and workmanship for twelve months from delivery.

The implied warranties of merchantability and fitness for a particular purpose and all other warranties, representations and conditions, express or implied by statute, trade usage or otherwise, except as set forth in this warranty, are excluded and shall not apply to the Products delivered.

The contents, data and information in this datasheet are provided by FCL Components Limited as a service only to its user and only for general information purposes. The use of the contents, data and information provided in this datasheet is at the users' own risk.

FCL Components has assembled this datasheet with care and will endeavor to keep the contents, data and information correct, accurate, comprehensive, complete and up to date.

FCL Components Limited and affiliated companies do however not accept any responsibility or liability on their behalf, nor on behalf of its employees, for any loss or damage, direct, indirect or consequential, with respect to this datasheet, its contents, data, and information and related graphics and the correctness, reliability, accuracy, comprehensiveness, usefulness, availability and completeness thereof. Nor do FCL Components Limited and affiliated companies accept on their behalf, nor on behalf of its employees, any responsibility or liability with respect to these datasheets, its contents, data, information and related graphics and the correctness, reliability, accuracy, comprehensiveness, usefulness, availability and completeness thereof. Rev. April 24, 2025.