

POWER RELAY

1 POLE—3, 5, 10 A (Medium Load Control)

FBR160 SERIES

■ FEATURES

- Compact with high power (3 A to 10 A)
- 6 types of contact materials available for home electronics and automobile applications
- Design conforms to the following safety standards
 - UL114 No. E63615
 - UL508 No. E3614
 - CSA No. LR64026
 - Japan Electric Appliance Control Law (150–300 V)
- For automatic assembly
 - Tube packaging suitable for automatic insertion equipment is available



■ ORDERING INFORMATION

[Example] FBR16 1 S E D 012 JH -CSA -*** -S
 (a) (b) (c) (d) (e) (f) (g) (h) (i) (j)

(a)	Series Name	FBR160, FBR160 Series		
(b)	Contact Arrangement	1 : 1 form C (SPDT) 3 : 1 form A (SPST-NC)		
(c)	Enclosure	S : Flux free N : Plastic sealed		
(d)	Coil Rating	E : 360 mW type C : 500 mW type (refer to the SPECIFICATIONS)		
(e)	Coil	D : DC Coil		
(f)	Nominal Voltage	(Example) 012: 12 VDC coil 024: 24 VDC coil (refer to the COIL DATA CHART)		
(g)	UL Standard and Contact Material	UL 114 recognized	UL508 recognized	Material / Rating
		U UK UH UW UHB UWB	R RK RH RW RHB RWB	Silver (3A) Silver-cadmium oxide (3 A) Silver-cadmium oxide (5 A) Silver tin oxide alloy (5 A) Silver-cadmium oxide (AC 10 A) Silver tin oxide alloy (DC 10 A)

(Continued)

FBR160 SERIES

(h)	CSA Standard	Nil : Non- CSA -CSA: CSA recognized, but only UL 114 or UL 508 types
(i)	Custom Designation	Suffix number for custom design
(j)	Package Style	Nil : Standard tray -S : Tube carrier

Note: The designation name is stamped on the top of the relay case as follows:
 Example: Designation ordered: FBR161NED012-H
 Stamp: 161NED012-H

■ COIL RATINGS

1. E (360 mW Coil type)

MODEL				Nominal voltage	Coil resistance (±10%)	Nominal current (at nominal voltage) approx.	Must operate voltage*	Must release voltage*	Maximum allowable voltage	Nominal power	Coil temperature rise
1 Form C type		1 Form A type									
Flux free	Plastic sealed	Flux free	Plastic sealed								
FBR161SED005 □	FBR161NED005 □	FBR163SED005 □	FBR163SED005 □	5 VDC	70 Ω	71 mA	80% max. of nominal voltage	10% min. of nominal voltage	210% of nominal voltage	Approx. 360 mW (at nominal voltage)	Approx. 30 deg (at nominal voltage)
FBR161SED006 □	FBR161NED006 □	FBR163SED006 □	FBR163SED006 □	6 VDC	100 Ω	60 mA					
FBR161SED009 □	FBR161NED009 □	FBR163SED009 □	FBR163SED009 □	9 VDC	150 Ω	50 mA					
FBR161SED012 □	FBR161NED012 □	FBR163SED012 □	FBR163SED012 □	12 VDC	400 Ω	40 mA					
FBR161SED024 □	FBR161NED024 □	FBR163SED024 □	FBR163SED024 □	24 VDC	1,600 Ω	21 mA					

Note: All values in the table are measured at 20°C.
 *: Specified values are subject to puls wave voltage.

2. C (50 mW Coil type)

MODEL				Nominal voltage	Coil resistance (±10%)	Nominal current (at nominal voltage) approx.	Must operate voltage*	Must release voltage*	Maximum allowable voltage	Nominal power	Coil temperature rise
1 Form C type		1 Form A type									
Flux free	Plastic sealed	Flux free	Plastic sealed								
FBR161SCD005 □	FBR161NCD005 □	FBR163SCD005 □	FBR163SCD005 □	5 VDC	50 Ω	100 mA	75% max. of nominal voltage	10% min. of nominal voltage	210% or nominal voltage	Approx. 50 mW (at nominal voltage)	Approx. 35 deg (at nominal voltage)
FBR161SCD006 □	FBR161NCD006 □	FBR163SCD006 □	FBR163SCD006 □	6 VDC	72 Ω	83 mA					
FBR161SCD009 □	FBR161NCD009 □	FBR163SCD009 □	FBR163SCD009 □	9 VDC	162 Ω	56 mA					
FBR161SCD012 □	FBR161NCD012 □	FBR163SCD012 □	FBR163SCD012 □	12 VDC	288 Ω	42 mA					
FBR161SCD024 □	FBR161NCD024 □	FBR163SCD024 □	FBR163SCD024 □	24 VDC	1,152 Ω	21 mA					
FBR161SCD048 □	FBR161NCD048 □	FBR163SCD048 □	FBR163SCD048 □	48 VDC	4,600 Ω	10 mA					

Note: All values in the table are measured at 20°C.
 *: Specified values are subject to puls wave voltage.

FBR160 SERIES

■ SPECIFICATIONS

Item		—	-K	-H	-W	-HB	-WB	
Contact	Arrangement and Style	1 form C or 1 form A, single contact						
	Material	Silver	Silver-cadmium oxide		Silver tin oxide alloy	Silver-cadmium oxide	Silver tin oxide alloy	
	Resistance (initial)	Maximum 100 mΩ (silver contact at 0.5 A 6 VDC/other contacts at 1 A 6 VDC)						
	Ratings (resistive load)		3 A 120 VAC		5 A 120 VAC		10 A 120 VAC (N.O.) 7 A 120 VAC (N.C.)	
			3 A 28 VDC		5 A 28 VDC	5 A 28 VDC		10 A 28 VDC
	Maximum Carrying Current	5 A				10 A		
	Maximum Switching Power	360 VA or 84 W		600 VA or 140 W	140 W	1,200 VA	280 W	
	Max. Switching Voltage*1	250 VAC or 125 VDC						
Minimum Switching Load*2	0.3 W (30 mA 5 V)			0.3 W (50 mA 5 VDC)	0.5 W (10 mA 5 VDC)	0.5 W (10 mA 5 VDC)		
Coil	Nominal Power	Approx. 360 mW (E coil type)/0.5 W (C coil type) (at 20°C)						
	Operating Temperature	-30°C to +80°C (no frost) *3						
	Operate Humidity	45 to 85% RH						
Time Value	Operate (at nominal voltage)	Maximum 10 msec						
	Release (at nominal voltage)	Maximum 5 msec						
Life	Mechanical	1 × 10 ⁷ operations minimum						
	Electrical (refer to the REFERENCE DATA)	DC	1 × 10 ⁵ operations minimum (at contact rating)					
		AC	1 × 10 ⁶ operations minimum (at contact rating)					
Other	Vibration Resistance	10 to 55 Hz (dc amplitude of 1.5mm)						
	Shock Resistance	No contact opening	100 m/s ² (11 ±1ms)					
		No damage	1,000 m/m ² (6 ±1ms)					
	Weight	Approximately 11 g						

*1 If the switching voltage exceeds the rated contact voltage, reduce the current. The current values vary according to the type of load.

*2 Values when switching a resistive load at normal room temperature and humidity, and in a clean environment. The minimum switching load varies with the switching frequency and operation environment.

*3 Based on UL Class A coil insulation system.

■ INSULATION

Item	FBR160 Series
Resistance (500VDC)	Min. 100MΩ
Dielectric Strength	Open contacts: 500VAC 1 min. Coil and contacts: 1,500VAC 1 min.

■ SAFETY STANDARD AND FILE NUMBERS

Type	Compliance	Contact rating
UL	UL 114 E 63615 (U, UK, UH, UW, UHB, UWB)	Flammability: UL 94-V0 (plastics) [U, UK, R, RK] 3A, 120VAC/30VDC (resistive) 1/10 HP, 120VAC
	UL 508 E 63614 (R, UK, RH, RW, RHB, RWB)	[UH, UW, RH, RW] 5A, 120 VAC/30VDC (resistive) 1/6 HP, 120VAC
CSA	CSA 2 No. 14 LR 40004, LR 61320 or LR 64026 (U, UK, UH, UW, UHB, UWB, R, RK, RH, RW, RHB, RWB)	[UHB, UWB, RHB, RWB] 10A, 250 VAC/125VAC (N.O. resistive) 7A, 250 VAC / 125VAC (N.C. resistive) 10A, 30 VDC (resistive) 1/8HP, 250VAC/125VAC

Also complies with VDE

DISCONTINUED (1998)

CHARACTERISTIC DATA

Range of operation temperature and voltage
E type [0.36 W type]

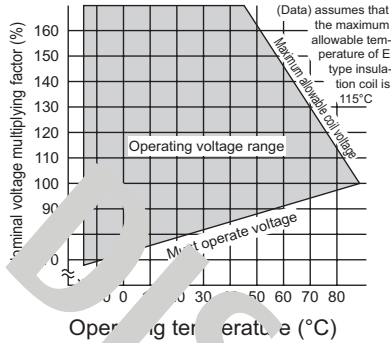

Maximum switching capacity (10 A type)

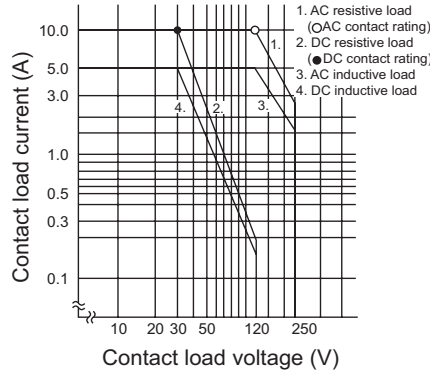

Maximum switching capacity (5 A type)

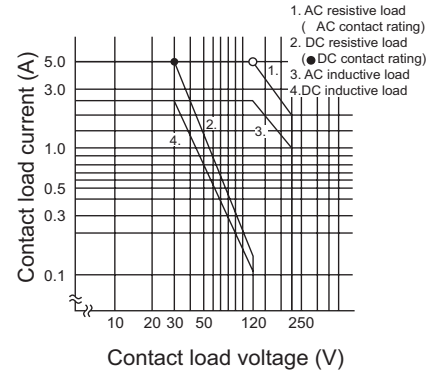

Life curve (5 A type)

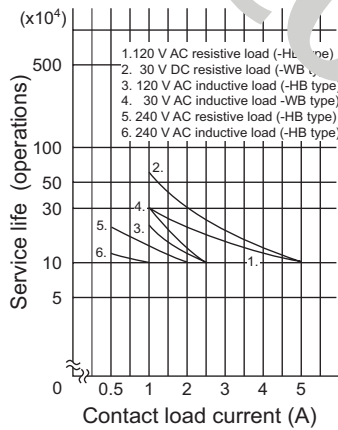

Life curve (10 A type, make side (N.O.))

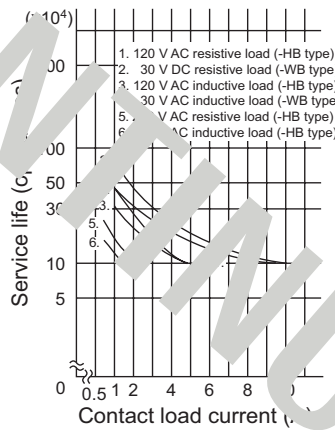

Life curve (10 A type, break side (N.C.))

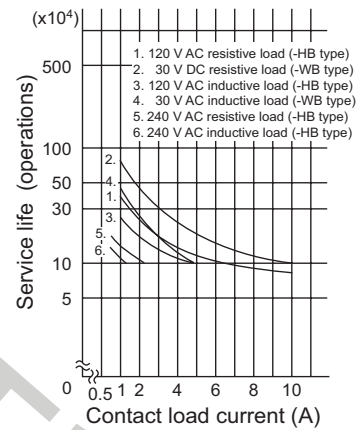

REFERENCE DATA

Distribution of operate and release voltage

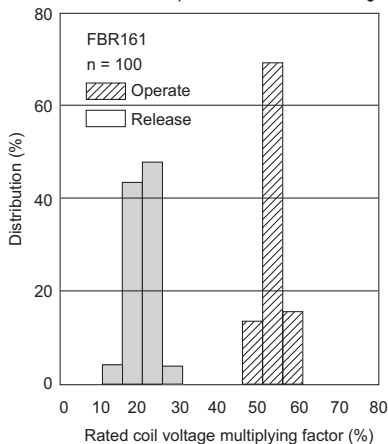

Distribution of operate and release time

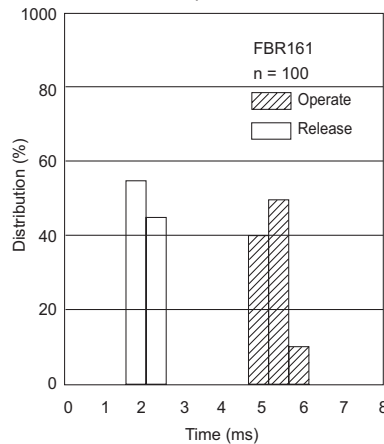

Distribution of contact resistance

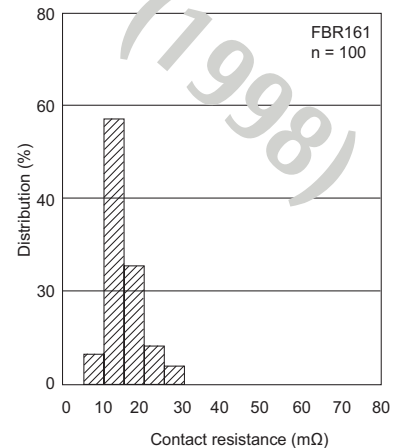

FBR160 SERIES

■ DIMENSIONS

● Dimensions

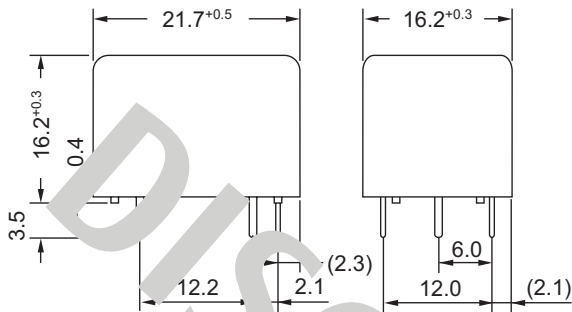

● Schematic (BOTTOM VIEW)

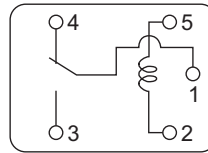

● PC board mounting hole layout (BOTTOM VIEW)

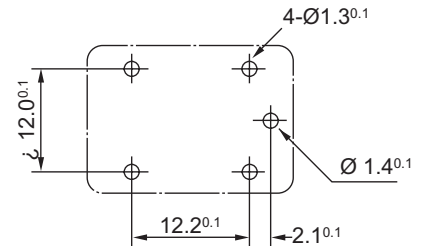

Note : For 1 form A type, terminal No.4 is removed.

● Tube carrier

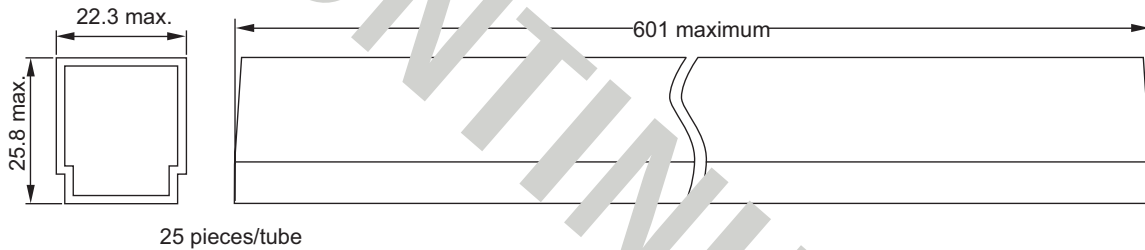

Unit: mm

Fujitsu Components International Headquarter Offices

Japan

Fujitsu Component Limited
 Gotanda-Chuo Building
 3-5, Higashigotanda 2-chome, Shinagawa-ku
 Tokyo 141 8630, Japan
 Tel: (81-3) 5449-7010
 Fax: (81-3) 5449-2626
 Email: promothq@fcl.fujitsu.com
 Web: www.fcl.fujitsu.com

North and South America

Fujitsu Components America, Inc.
 250 E. Caribbean Drive
 Sunnyvale, CA 94089 U.S.A.
 Tel: (1-408) 745-4900
 Fax: (1-408) 745-4970
 Email: components@us.fujitsu.com
 Web: <http://us.fujitsu.com/components/>

Europe

Fujitsu Components Europe B.V.
 Diamantlaan 25
 2132 WV Hoofddorp
 Netherlands
 Tel: (31-23) 5560910
 Fax: (31-23) 5560950
 Email: info@fceu.fujitsu.com
 Web: emea.fujitsu.com/components/

Asia Pacific

Fujitsu Components Asia Ltd.
 102E Pasir Panjang Road
 #01-01 Citilink Warehouse Complex
 Singapore 118529
 Tel: (65) 6375-8560
 Fax: (65) 6273-3021
 Email: fcac@fcal.fujitsu.com
 Web: <http://www.fujitsu.com/sg/services/micro/components/>

©2007 Fujitsu Components America, Inc. All rights reserved. All trademarks or registered trademarks are the property of their respective owners.

Fujitsu Components America or its affiliates do not warrant that the content of datasheet is error free. In a continuing effort to improve our products Fujitsu Components America, Inc. or its affiliates reserve the right to change specifications/datasheets without prior notice.
 Rev. November 30, 2007.