FCL Components

**Engineering Reference
Relays**

ENGINEERING REFERENCE

RELAY ENGINEERING REFERENCE —Contents—

1. TYPES OF RELAYS

1.1 Relay Mounting and Terminal Shape	3
1.2 Printed Circuit Board Relay	3
1.2.1 Types of sub-miniature relays	3
1.2.2 Structure of sub-miniature relays	3
1.2.3 Printed circuit board relay mounting and soldering patterns	4
1.2.4 Polarized latching relay	5
1.2.5 High frequency relay	5
1.2.6 Solid state relay (SSR)	7

2. HOW TO SELECT AND USE RELAY

2.1 How to Select Relay	7
2.1.1 Main points to select proper relay	7
2.1.2 Contact	8
Contact load	8
Selection for the relays by contact load	9
Switching frequency of contact	10
2.1.3 Winding and energization	10
AC relay and DC relay	10
Special winding circuit	11
Input power demand and coil resistance	11
2.1.4 Performance	12
Contact resistance	12
Contact weld	14
Operate voltage and release voltage	14
Relay's temperature rise and operating temperature range	15
Hot coil and cool coil	16
Ambient temperature and allowable winding voltage	16
Operate time and release time	17
Dielectric strength and insulation resistance	17
Characteristics for environments	19
Relay reliability	20
Life	21
2.1.5 Industrial standards and safety standards	22
Industrial standards	22
Safety standards	22
2.2 Recommendation and Precaution	23
2.2.1 Silicone compound should be avoided	23
2.2.2 Strong magnetic field can cause disorder of operate and release voltages	23
2.2.3 Guide for connection of load	23
2.2.4 Precautions for mounting of relay	24
Schematics and PC board mounting hole layout	24
How to use socket	24
Others	25
2.2.5 Transistor driver	25
Relay driver	25
How to select transistor	25
Back electromotive force prevention element	25
Precautions for transistor driver	25
2.2.6 Check of contact for synchronization with AC load phase	26
2.2.7 Usage of latching relay	27
Example of latching relay driver	27
Precautions for connection of latching relay winding	27
Other precautions	28
2.2.8 Mounting of relay on printed circuit board	28
Mounting of relay on printed circuit board and designing of circuit pattern	28
Precautions for manual soldering	29
Precautions for automatic soldering	30
Precautions for washing	31

1. TYPES OF RELAYS

1.1 Relay Mounting and Terminal Shape

- (1) Printed Circuit Board Relay
This relay is designed to be directly mounted onto printed circuit boards. More than 90% of relays are currently this type.
- (2) Plug-in Relay
This relay is attachable to fixed socket or terminal table.
- (3) Bracket fixing Relay
This relay is a type of fixing upside or bottom of cover with screw.

1.2 Printed Circuit Board Relay

We at FCL Components have achieved both high sensitivity and sub-miniaturization with successful features as described below:

- (1) Dimensions on each piece parts were decided by detailed analysis of magnetic circuit: all relays.
- (2) High-efficient magnetic circuit was developed by setting an armature in a high magnetic field inside of exciting coil and minimizing external reluctance to increase attracting force: FBR20H, SY, RY, JY relays, etc.
- (3) High sensitive magnetic circuit was developed by using permanent magnet: FBR10, FBR46, A, RA, RA4 relays, etc.

1.2.1 Types of sub-miniature relays

The sub-miniature printed circuit board relay is classified by outside dimensions into flat, slim and cubic types, which are shown in Fig. 1.1 accompanied with description of their main features.



	Flat Type	Slim Type	Cubic Type
Appearance	 A AS	 FBR10 NY	 FBR210 LZ
Characteristics	1. A particularly low height compared with the length of one bottom edge. 2. This type is suitable to be incorporated in thin body equipment or used in a small distance space, and used with printed circuit board(s) mounted on a rack.	1. A particularly short length of one bottom edge compared with height. 2. Suitable in case where the area allotted to printed circuit board is limited to a small one or where the only requirement is to be of a lower height compared with other components such as transformer and capacitor.	1. Rather close to cubic, apart from flat type as well as slim type. 2. A smaller space as a whole.

Fig. 1.1 Types of compact relays

1.2.2 Structure of sub-miniature relays

This relay is classified into 4 types by the structure of terminal holes in the case, structure between case and base or cover and mounting pattern of relay onto printed circuit board: enclosure type, flux free type, plastic sealed type (washable type) and surface mount type, which are shown in Fig. 1.2.

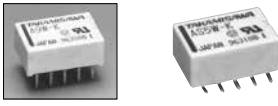
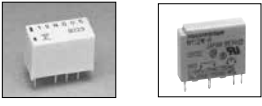
- **Enclosure type:** There is a gap between cover and case or terminals and body of case. This structure needs manual soldering, because, if soldered automatically, there is the possibility of contaminating the contact housed in relay with flux used when mounting the relay on printed circuit board, which can penetrate, in a molten state, into the interior of relay.

ENGINEERING REFERENCE

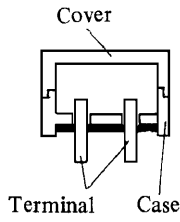
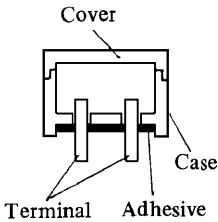
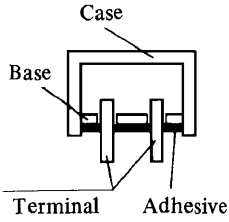
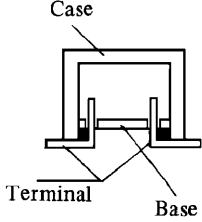
Item \ Relay type	Enclosure Type	Flux Free Type	Washable Type (Plastic Sealed Type)	Surface Mount Type
Structure				
Characteristics	There are gaps between terminals and the body of the case as well as between the cover and the case, respectively.	The gaps between terminals and the body of the case are sealed by adhesive and the distance from bottom to the level where the cover and the case fit is significantly large.	All gaps such as those between terminal-base and case-base are sealed by adhesive.	All gaps such as those between terminal-base and case-base are sealed by adhesive. Terminals are bent in the form of gull wing.
Mounting pattern	Insertion mounting	Insertion mounting	Insertion mounting	Surface mounting
Automatic flux coating	X	○	○	○
Automatic soldering	X	○	○	○
Automatic washing (whole washing)	X	X	○	○
Manual soldering	○	○	○	△

Note: ○ suitable; X: unsuitable; △: includes both of suitable and unsuitable

Fig. 1.2 Relationship between relay structure and soldering pattern

- **Flux-free type:** In this model, the gaps between terminals and body of case are sealed by adhesive and the distance from bottom to the level where cover and case fit is large enough not to allow flux to penetrate into the interior along terminals by the effect of capillary phenomenon. However, the whole washing is not allowed.
- **Plastic sealed type (Washable type):** The gaps between terminals and body of case or base as well as case and base or cover are all plastic-sealed. No flux can enter the interior and the whole washing is allowed.
- **Surface mount type:** For all the three types mentioned before, the terminals inserted into the holes drilled in printed circuit board are soldered from the back side of the board.

To the contrary, no hole is drilled in printed circuit board for this model but the conductive patterns arranged on the mounting face of board and terminals of relay are electrically connected and then the relay is bonded to the board. Usually this relay assembly is plastic-sealed.

These plastic sealed relays have no fear of the contact being contaminated with dust or oil mists and have large effect to screen harmful gases for the contact.

1.2.3 Printed circuit board relay mounting and soldering patterns

There are patterns in mounting and soldering as shown below. They should be selected with careful consideration of the structure and form of relay.

- (1) Insertion mounting
 - 1) Manual soldering
 - 2) Automatic soldering: no whole washing
 - 3) Automatic soldering: whole washing

- (2) Surface mounting

The item 2) in (1) needs the use of flux free type or plastic sealed type and the item 3) needs the plastic sealed type.

The item (2) needs, of course, the use of surface mount type relay.

For the insertion mount type relay, the thickness of printed circuit board includes 0.8, 1.2, 1.6 and 2.0 mm. However, a thickness of 1.6 mm is suitable for ordinary use from the standpoint of relay's dead weight, so that standard length of terminal of the relay is matching the thickness of 1.6 mm.

The location and diameter of terminal holes for each relay are described in each appropriate catalogue. The cross sectional area of each relay terminal is determined according to its carrying current capacity, so that the sizes of the holes in boards for the relays with a larger current capacity should be comparatively large.

1.2.4 Polarized latching and non-latching relays

As to the operating characteristic of these relays, the non-latching relay is restored when the coil is deenergized after it is once energized to make the relay actuated. In contrast, in the latching relay, operation (set) and release (reset) are conducted using each pulse current, a set or reset state is maintained even if energizing current is suspended after it is once set or reset, therefore, no need of power supply to maintain a set or reset state. This phenomenon results from the magnetic pull force by remanent magnetism.

The latching relay is available in polarized latching type.

• Polarized latching type relay

The polarized latching type relay incorporates a permanent magnet in part of the magnetic circuit. Its remnant attraction ensures that the latching characteristics are maintained. This relay is available in two types; a single-coil latching type and a double-coil latching type. The polarized type relay is set or reset by supplying a driving pulse larger than the predetermined setting or resetting voltage (current) to the coil. Fig. 1.3 shows an example of the operating characteristics of a polarized latching relay. Usually, a pulse width of around 10 ms is sufficient to set or reset a polarized type relay. With the single-coil relay, setting or resetting are performed by reversing the polarity of the current supplied to the coil whereas the double-coil type features setting and resetting coils equipped with respective terminals and is operated by supplying voltage (current) of predetermined polarity to the respective coils.

A, FBR46 and RA type relays have variations of the polarized latching type relay.

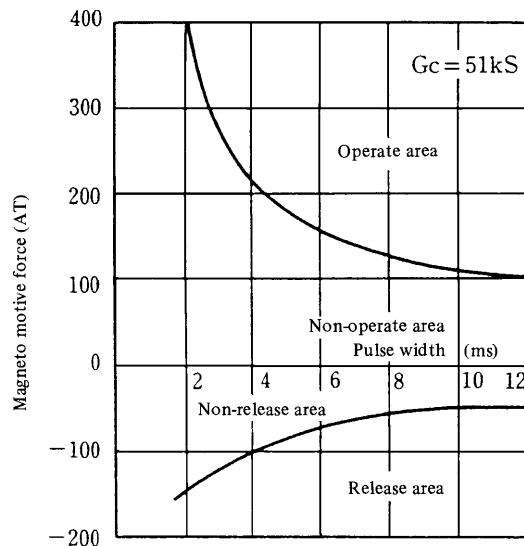

Fig. 1.3 Operating characteristics of polarized latching relay

1.2.5 High frequency relay

In recent years, high frequency signals such as VHF and UHF have been widely used. The equipment dealing with such signals is equipped with a high frequency relay with outstandingly improved high frequency characteristics as a signal switching element.

The high frequency relay requires the following three characteristics, which will be explained using a model circuit shown in Fig. 1.4.

Considering losses, the transmission impedances in high frequency circuits are unified into 50Ω or 75Ω and so the high frequency relays, too, are used under the same conditions.

- (1) Isolation characteristics: This indicates the level of signal leakage across the contact which are in an open state. Generally the leak is increased with increase in frequency of signal. The isolation is expressed by the following formula. The larger the value the better the isolation.

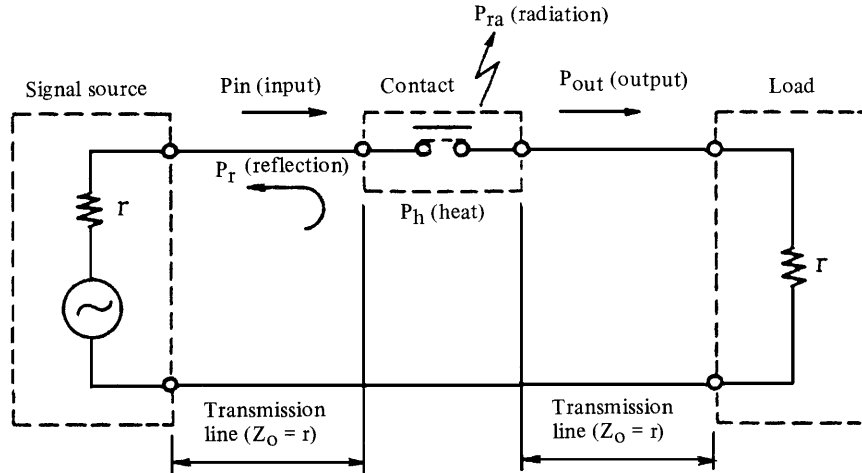

Note: If assumed to be an ideal status as no loss, no reflection and no leak in signal source, load and transmission line, then: $P_{in} = P_{out} + P_r + P_{ra} + P_h$ $Z_0 = 50\Omega$ or 75Ω

Fig. 1.4 A model circuit for signal application to relay contact

$$\text{Isolation} = -10 \log \frac{P_{out} \text{ (output power)}}{P_{in} \text{ (input power)}} \text{ (dB)} \dots\dots\dots(1)$$

- (2) Insertion loss characteristic: This indicates the signal insertion loss in a closed state of contact. With increase in frequency of signal, each loss is increased, as a result, the insertion loss is increased together. Insertion loss is defined by the following formula. The smaller the value, the more desirable the status is.

$$\text{Insertion loss} = -10 \log \frac{P_{out} \text{ (output power)}}{P_{in} \text{ (input power)}} \text{ (dB)} \dots\dots\dots(2)$$

- (3) Return loss characteristic or V.S.W.R.: This indicates the signal reflection loss in a closed state of contact. With increase in frequency of signal, the reflection is increased. The return loss is expressed by the following formula. The larger the value, the smaller the reflection.

$$\text{Return loss} = -10 \log \frac{P_r \text{ (reflection power)}}{P_{in} \text{ (input power)}} \text{ (dB)} \dots\dots\dots(3)$$

The reflection characteristic is expressed by V.S.W.R.: (voltage standing wave ratio), too, which can be calculated from return loss by use of following formula:

$$\text{Reflection coefficient } p = 10^{-\frac{RL}{20}} \dots\dots\dots(4)$$

where RL: return loss (dB)

$$\text{V.S.W.R.} = (1 + p) / (1 - p) = (1 + 10^{-\frac{RL}{20}}) / (1 - 10^{-\frac{RL}{20}}) \dots\dots\dots(5)$$

Here, V.S.W.R. ≥ 1 . The closer to 1, the smaller the reflection.
To improve the high frequency characteristic, the high frequency relay is provided with a number of earth terminals. UM1 type relays are categorized in high frequency relay.

1.2.6 Solid State Relay (SSR)

The solid state relay is a semi-conductor relay, often called, simply, "SSR."

The SSR is equipped with a set of output and input terminals insulated from each other by means of photo coupler. Once an input signal is applied to the input terminal, the output terminal is closed, allowing a current to flow in the load circuit.

SSR is of a contactless type and has a capability of high speed and high frequency switching operation so that in recent days it has been widely used, substituting for traditional contact type relays.

Since the SSR, as mentioned above, is equipped with no movable part, it has the following strong and weak points compared with electromagnetic relays:

- 1) A longer lifetime due to contactless system
- 2) Quick response
- 3) No malfunction caused by vibration and shock
- 4) No degradation in performance caused by dust, gas, etc.
- 5) Rather weak in resistance to external noises
- 6) The SSR for use for large current loads requires a heat sink device to avoid excessive heat generation, resulting in difficulties in giving it a compact structure.

• Block diagram

Fig. 1.5 is the block diagram of an example of a SSR equipped with photo coupler, in which the insulation system, circuit construction and input and output wave form are represented for each of AC and DC loads.

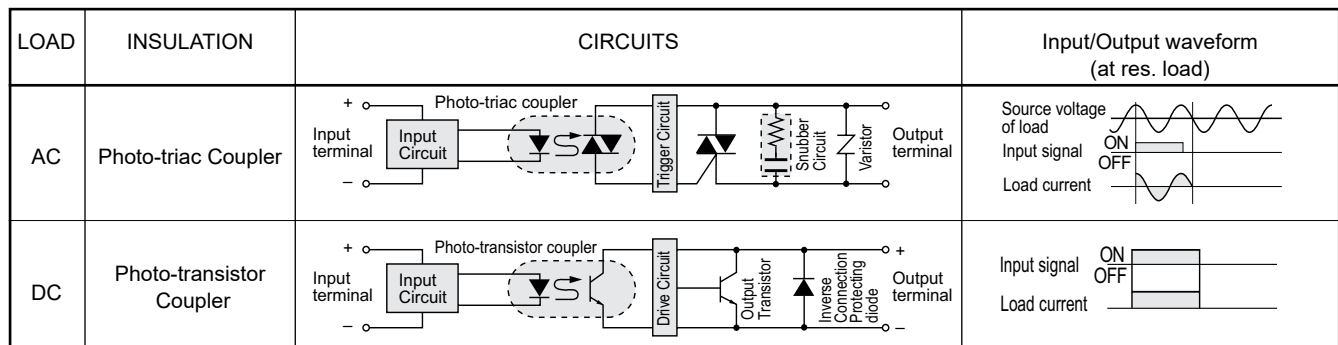

Fig. 1.5 An example of block diagram

2. HOW TO SELECT AND USE RELAY

2.1 How to select relay

2.1.1 Main points to select proper relay

Main points to select proper relay are as follows:

- (1) Points for contact
 - 1) Forms and number of contact combinations
 - 2) States of contact load
AC or DC?; resistive or inductive or capacitive or lamp?; occurrence of back electromotive force or inrush current?
 - 3) Level of contact load
Large or small current?; Switch on or not for current load?; Switch off or not for current load?
 - 4) Frequency in switching operation
 - 5) Demand for life in switching operation

- (2) Points for coil
 - 1) Coil power source
DC or AC?
 - 2) Fluctuation in supply voltage
 - 3) Energizing method and circuit
Necessity of special energizing circuit
 - 4) Coil resistance
 - 5) Operate and release voltages
 - 6) Operate time and release time

- (3) Insulation
 - 1) Dielectric strength
 - 2) Insulation resistance
 - 3) Surge strength
- (4) Environment
 - 1) Range of ambient temperature or humidity
 - 2) Environmental atmosphere
 - 3) Vibration and shock
- (5) Mounting
 - 1) Outside dimensions
 - 2) Fixing and soldering of terminals
 - 3) Mounting method
- (6) Others
 - 1) Safety standards and other standards
 - 2) Special specifications or conditions

2.1.2 Contact

2.1.2.1 Contact load

The phenomena in the contact of magnetic relay greatly vary depending on contact load and current level as well as contact material and size, opening speed and contact bounce at switching operation.

- (1) The allowable contact-switching current for DC load is smaller than that for AC load
AC current is periodically reduced to zero but DC current is not, so the arc discharge current at shutoff of current is hard to extinguish for DC current as compared with AC current. The duration of arc discharge is longer in DC circuit than in AC circuit. The allowable maximum contact -switching current is smaller for DC load than for AC load.
Be careful of the difference between the max. switching load listed in catalog for AC and DC ones.
- (2) The inrush and breaking currents in resistive load circuit are equivalent to those in steady state
Resistive load is used as a standard load in life test and reliability test. The contact life listed in catalog is based on resistive load.
As to loads for practical use, there is no load composed of resistance only. But some heaters are very close to this status.
- (3) A high back electromotive force at caused in breaking in inductive load circuit
Electromagnetic relays, solenoids and motors are the inductive load. They generate a high back electromotive force between relay contacts when they break in their circuits, which causes arc discharge.
As power factors of those devices are widely distributed, the contact life for respective power factor is listed in the catalog.
It should be taken into consideration that the life is decreased as the power factor is lowered. According to circumstances, a spark quenching device should be used. (Refer to Fig. 2.3).
In a circuit with such a load as motor, solenoid and transformer, an inrush current 5 to 15 times as large as the steady current is generated at the instant of energizing, so the contact of selected relay should have a sufficiently large surplus allowable load.
- (4) A large inrush current in capacitive load
In a circuit with a load of capacitor, an inrush current 20 to 40 times as large as the steady current is often produced, causing contact welding failure. Care should be taken with a long transmission line or cable capacitance. In accordance with circumstances, a surge suppressor should be used. (Fig. 2.4)
- (5) A large inrush current in lamp load circuit
In a lamp load circuit, an inrush current 10 to 15 times as large as the steady current is produced, causing contact welding failure. Careful selection for a relay suitable for inrush current is required.
- (6) High frequency load requiring special characteristics
Nowadays, relays are used to switch high frequency signals of 30 to 1,000 MHz. These relays are required to have high level of isolation, insertion and return loss characteristics which are not demanded for DC loads and low frequency AC loads.
The relays included in this category are UM1 type relays.
Table 2.1 outlines the types of loads and levels of inrush current.

Table 2.1 The types of loads and level of inrush current

Types of loads	Level of inrush current
Incandescent lamp	10~15 times as large as the steady current
Mercury lamp	About 3 times as large as the steady current
Fluorescent lamp	5~15 times as large as the steady current
Motor	5~15 times as large as the steady current
Solenoid	10~20 times as large as the steady current
Contactoer	3~10 times as large as the steady current
Condenser	20~40 times as large as the steady current
Transformer	5~15 times as large as the steady current

2.1.2.2 Selection for the relays by contact load

The range of currents to be applied to relay contact runs wide from an order of μA to around 30 A. A large current load causes the contact arc discharge the moment of switching. The phenomena appearing at contact are greatly different by arc discharge. Therefore, we show relays corresponding to contact load classified as Table 2.2. The criterion for classification is arc current. Each value of minimum current in this Table is just a rough reference.

Table 2.2 Classification of contact load current

Classification	Nominal current	Minimum current	Note
From micro current through small one	100 mA	0.05 mA	Range does not have arc discharge.
Small current	Several Amps.	10 mA	Arc discharge is found.
Medium current	~ 15 A ~	500 mA	Arc discharge shows up strongly.

(1) Relays for current loads ranging from micro through small one

The maximum current to be switched in this classification is about 1 to 2 A.

The relays, in this classification are suitable to be used in signal transmission equipments such as communication apparatus.

Increase in contact resistance:

The contact resistance is the most prominent problem in this micro current range use. The possible causes of increase in contact resistance are as follows:

Films formed on the contact surface (oxides, sulfides, etc.) resulting from harmful gases in atmosphere (sulfide gas, chloride gas, nitrogen oxide, ammonia, benzene, styrene, etc. exhausted from cars, spa and paints), deposits (brown powder and black powder) and dust.

Contact resistance stabilizing measures:

The contact resistance stabilizing measures for microcurrent relays are as follows:

- 1) Use of contact made of gold clad Ag-Pd alloy or gold clad Ag
- 2) Use of twin contact
- 3) Increase of contact wipe
- 4) Adoption of sealed relay

(2) Relays for current loads ranging from small through medium ones

The level of current in this range is 3 to 5 A in maximum contact rating.

The use of relay in this range is versatile, such as household appliances, air conditioners, audio devices, business machines and car devices.

By applying the same material and structure as those for microcurrent loads to the contacts in this range or employing a material with excellent antiweldability as the contact material, it is capable to apply the same type relay for loads from microcurrent through 5 or 10 A.

Electrical wear of contact:

The problems in this current load range are electrical wear and weld.

The arc discharge at contact arise in large current load. This causes wear and/or transition of contact material, welding, bridging, etc., resulting in failures and/or reduction in life of the contact.

Also, the deposition of scattered contact material on the insulators in the vicinity of contact causes degradation in insulation resistance, often leading to life-end of the relay.

Measures against wear and weld of contact:

The measures against electrical wear and weld to keep the stabilization of quality and performance are as follows:

- 1) Selection of material and dimensions reliable enough for the contact to guarantee the life described in the catalog.
- 2) Adoption of such a contact spring assembly structure as be able to easily obtain the contact with satisfactory contact follow and force.
- 3) Expansion of contact wipe to secure the stabilization of contact resistance and improvement in resistivity against contact weld.

- (3) Relays for current loads ranging from medium through large ones:

With the recent trend towards small-sized equipment, miniature relays have been penetrating into a part of the area of electromagnetic contactor. The level of current in this range is 15 to 30 A in maximum contact rating.

In the relays in this category, the phenomena as mentioned in the description of effects of small through medium current loads occur more intensively, so that the materials resistance to welding and bridging such as AgCdO and AgSnO₂ are used as contact materials. Also, to reduce heat generation, the relays in this range are constructed with large-sized contacts and springs made of a material with a large conductivity.

2.1.2.3 Switching frequency of contact

If the switching frequency is excessively large in a contact subject to intensive arc discharge at switching due to a large contact load, the contact and contact spring will be extraordinarily heated by the effect of arc discharge, leading to shortening in contact life.

Usually, the contact lives listed in catalogs are those tested under the following switching frequencies. If a larger frequency is expected, make a confirmation test.

Contact-switching current load	Standard switching frequency
Under 3 A	1 sec. ON, 1 sec. OFF
3 A or greater	3 sec. ON, 3 sec. OFF

2.1.3 Winding and energization

2.1.3.1 AC relay and DC relay

- (1) Alternating current (AC) relay

Generally, A portion of the pole of AC relay is equipped with a shaded ring, which operation is carried out by direct energization from alternating-current source.

In this type of relay, the armature vibrates and beats at a voltage of less than operate value, so that the drop of supply voltage during, e.g., a period of motor startup is accompanied with beat of armature and can cause burning or welding of contact.

Nowadays, the set of sub-miniature relay and rectifier are used as AC relay because of easy availability of high performance and quality rectifiers.

- (2) Direct current (DC) relay

The magnetic pull force for drive of relay is generated by a magnetomotive force expressed in product of current and number of turns of winding; therefore, the coil current is the base of pull force.

From the standpoint of use of relay, however, voltage is convenient in most cases compared with current so that usually the kind of winding is selected on the basis of voltage.

In general relay, the resistance and number of turns of winding are selected on the basis of drive voltage. In other words, if, for instance, the drive voltage is different between two relays, the resistance and number of turns of winding are also different between them.

The nominal voltages of coils is a voltage correspond to the base of energization. Usually the standard nominal voltages are 1.5, 3, 4.5, 5, 6, 9, 12, 18, 24, 36, 48, 60, and 100 VDC. As to the standard nominal voltage of each type of relay, refer to the list in appropriate catalog.

(3) Fluctuation in power source

Any of rectified DC current from AC source, battery and dry cell are available as the power source of DC relay.

Ripple of rectified current is 5% or less:

The current with no ripple is ideal as the current source for DC relay. In practice, however, the criterion for ripple is generally defined as 5% or less. This percentage of ripple is that calculated using the formula described in Fig. 2.1. As to the fluctuation in voltage, refer to next paragraph for battery.

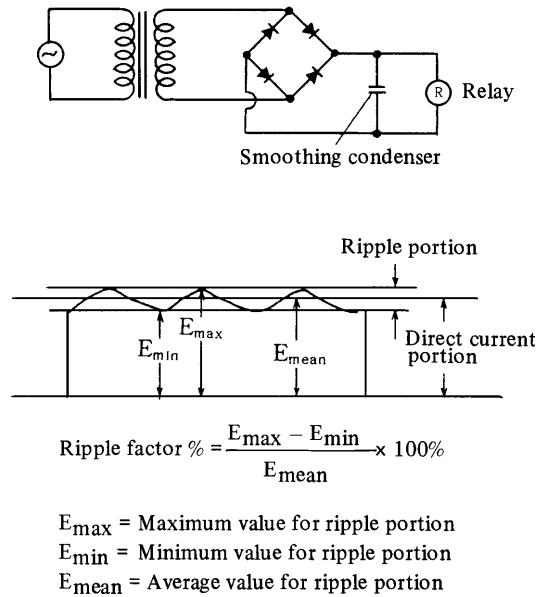

Fig. 2.1 Ripple factor of rectifications's circuit

Battery or dry cell as power source:

Excessively large fluctuation in voltage can cause suspension of relay operation at around lower limit of voltage and burning or degradation of coil at around upper limit.

It is required, therefore, to check for fluctuation in supply voltage beforehand and select a relay capable of operating safely at required ambient temperatures. The relations between ambient temperature and applicable voltage are described in Section 2.1.4.6.

2.1.3.2 Special winding circuit

For the circuit such as a pulse current is used for operation and release of relay and power is not supplied for maintenance of operation and release statuses, the latching relay should be selected. The winding latching relay includes one coil type and two coil type.

The one-coil type relay uses the same coil but changes the polarity of pulse current for both of operation (setting) and release (resetting). In the two-coil type relay, in contrast, the operation coil (set coil) and release coil (reset coil) are connected to the operation (set) and release (reset) circuits, respectively.

For setting or resetting in polarized latching relay, each of a pulse current corresponding to coil's nominal voltage, or a pulse current larger than the operation and release current respectively is available.

In non-polarized latching relay, in contrast, a pulse current within a specified range or the nominal voltage, in the release current circuit with a specified resistance must be applied to release the relay being in an operation (set) status, because the release (reset) current is required to be less than the reoperation current.

2.1.3.3 Input power demand and coil resistance

(1) Input power as one important factor for selection of relay

The input power of each relay is listed in the coil data chart of catalog. The input power of recent subminiature relays are as small as shown in the following:

Large current power relays 1.2 W; medium through small current general purpose relays 0.7 W to 0.2 W; less than small current general purpose relays 0.6 W to 0.15 W.

The lower input power as mentioned above contributes to power saving and opens the way for high density mounting because of low heat generation, thus it has become an important factor for selection of relay.

(2) Coil resistance

The resistance of each coil is specified according to the nominal voltage of the coil while the input power is specified for each type of relay.

In the general relays, the nominal value of each coil resistance is at 20°C and the allowable deviation is limited to within $\pm 10\%$.

Most of magnetic coil wires are polyurethane enameled copper wires. The resistance of Cu wire increases/decreases $\pm 0.4\%$ as the temperature does by 1°C.

2.1.4 Performance

2.1.4.1 Contact resistance

(1) Outline

The contact resistance of relay contact consists of constriction resistance, which arises from focusing of current to a small area of contact pieces being in contact with each other, and transition resistance (film resistance) of the film layers being in contact with each other.

The contact resistance of clean surfaces is extremely small, such as several m Ω . In practice, however, some kind of film layer is formed on the almost all of contact surfaces and the contact resistance varies depending on the physical properties of the film.

Usually, the contact resistance is measured between terminals of relay so that the conductor resistance of contact spring is included in the value of contact resistance.

(2) The relationship between contamination of contact surface and contact resistance

The possible causes of contamination, which effects increase in contact resistance, are as follows:

- 1) Adherence of fiber, scale and particles of plastic mold, powdery soil, etc.
- 2) Adherence of silicone oxides
- 3) Adherence of various kinds of non-conducting material and deposits of non-conducting material produced through chemical reaction with the gas adsorbed onto the contact face.
- 4) Oxidation and sulfuration of metallic powders in adherence to contact surface
- 5) Oxidation and sulfuration of contact material itself
- 6) Adherence of organic powders by friction
- 7) Adherence and deposition of carbon powders produced at the surface of contact

(3) Cleaning of contact surface

Effective cleaning methods are as follows:

- 1) Cleaning by air blower: Air blower is usually used at manufacturing process.
- 2) Cleaning by mechanical operation: Collision and rubbing motion of contact occur at mechanical operation of relay, which work to break film layers on contact surfaces. Therefore, the repeat of this operation can effect cleaning of contact surfaces.
- 3) Cleaning by arc discharge: The heat generated by arc discharge works to break the film produced by contamination, resulting in dissipation of contaminants. Therefore, there occurs no contact defect due to contaminant film where the current load is large enough to bring about a high energy arc discharge.

(4) The relationship between contact force, contact wipe and contact resistance

The contact resistance is decreased as contact force is increased but application of a large contact force to sub-miniature relay is incapable. To cover such weak points, countermeasures such as twin contact and sealed relay have been developed and, in addition to them, the distance of contact wipe is increased, which is helpful for stabilized resistance.

As a result, the quality of existing low current level sub-miniature relay has been improved to such a level as a contact force of as small as around 4 g is enough to offer a satisfactory contact reliability.

At the instant of opening and closing of contact, the contact surfaces are slid together, effecting breakage of non-conductive film formed on the contact surfaces. It is proved by tests that several μm of sliding travel is enough to have the surface cleaned, bringing about great reduction in contact resistance.

(5) Plastic sealed relay and contact resistance

If a relay is housed in a plastic case, the increase in contact resistance caused by contaminated atmosphere can be held back. If house and sealed, the effect is certainly improved greatly.

Thus, the plastic sealed sub-miniature relay has advantages such that not only the cleaning at the mounting process is available but also it can be protected during service in field from contamination by gases and dust contained in the atmosphere, as a result, maintain a stable contact resistance.

In a plastic sealed, however, the gas produced from the materials of assembled parts is also shut up in the enclosure so that the carbon powders sometimes are deposited on the contact surface and increase in contact resistance and/or wear of contact are accelerated. Therefore, the measures taken actually in the factory to prevent such troubles in seal relays are the selection of materials whose gas release at high temperatures is not significant in amount and/or the adoption of de-gassing treatment at the stage of manufacturing.

(6) Improvement of contact reliability by use of twin contact

The structure of twin contact is such that, as shown in Fig. 2.2, at least one of a pair of contact is composed of bifurcated spring and each bifurcated spring is attached contact piece. In addition, the contact without bifurcated spring is called 'single contact'.

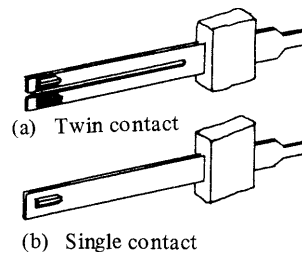

Fig. 2.2 Twin contact & single contact

The bifurcated spring is cut deeply enough so as to keep a good contact even when some insulating particle is trapped between contact surfaces of one side. In that case, the other side contact of twin can always serve to keep a good contact, for the sufficient mechanical independence between the separate twins. Thus, the adoption of twin contact has successfully reduced contact failures.

(7) The relationship between contact voltage/current and contact resistance

Increase in voltage brings about dielectric breakdown of film on contact surfaces, leading to decrease in contact resistance, and increase in current causes increase of Joule heat, resulting in local softening or melting of contact point and, in its turn, reduction in contact resistance.

Thus, the contact resistance varies depending on voltage and current for the contact point so that the evaluation tests of contact resistance should be conducted at a voltage and current near actual ones.

(8) Wear of contact and its influence on contact resistance

The switching operation with no current or micro current load causes almost no wear of contact, e.g. only several μm in wear depth at 10 million switching operation. Thus, the increase in contact resistance by contact wear is negligible in above loads. A spark discharge at switching of contact is sometimes followed by glow or arc discharge. The glow discharge occurs in a relatively small current load whose effect on contact erosion is rather little. The arc discharge is often accompanied with a large quantity of transfer or erosion of contact metal due to its large current density.

When switching operation is conducted in an organic gas atmosphere, the organic gas adsorbed on the contact surface is decomposed to produce carbon powders, resulting in deposition of them on the surface of contact. This status is called "activation of contact", making the contact susceptible to arc discharge. The activation of contact acts to increase the contact resistance if contact load is small. With increase in current load at switching, arc discharge becomes intensive enough to cause erosion of contact metal, which effects reduction in contact force, as a result, making susceptible to contact failures and, to the worst, leading to end of life.

To prevent erosion and transfer of metal, some adequate arc discharge preventing circuit is required. A spark quench device is employed for inductive load. Fig. 2.3 shows examples of circuits equipped with a spark quench device.

The capacitive load switching operation produces sometimes a short arc discharge and, if contact bounce occurs, a large current arc. Care should be taken that a circuit composed of a long cable release the charges accumulated in the cable, too. Such a circuit requires a surge suppressor as shown in Fig. 2.4.

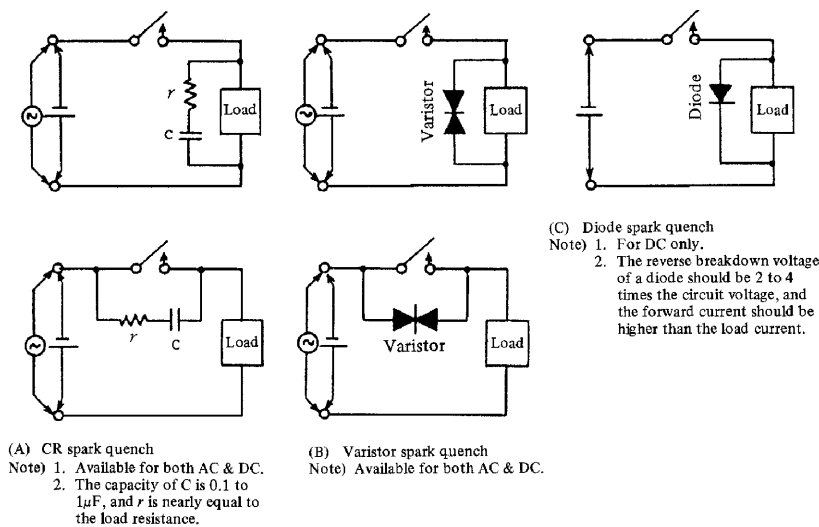

Fig. 2.3 Example of circuits equipped with a spark quench device

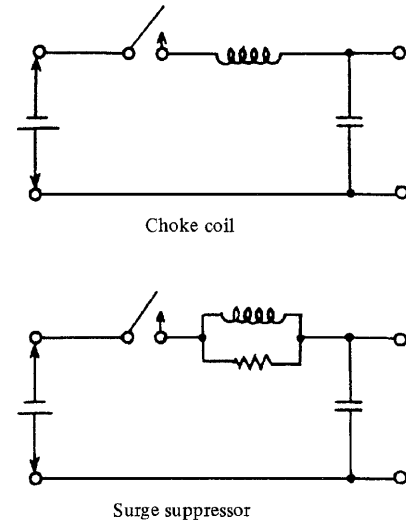

Fig. 2.4 Example of surge suppressor

(9) Testing procedure for contact resistance

The detail of contact resistance testing procedure is described in IEC Publication 255-7 Electrical Relays Part 7: "Test and measurement procedure for electromechanical all-or-nothing relays", Whose some essential points are as follows:

- 1) Four terminal testing method shall be applied, in which both of voltage and current terminals are used.
- 2) Testing voltages and currents shall be applied after contact is closed and the contact be opened after the loads are disconnected.
- 3) The testing voltages and currents should be near the actual operating loads, the voltages and currents to be used in tests are specified in above publication.

2.1.4.2 Contact weld

The cause of contact weld is a large current arc discharge produced by the effect of contact bounce at closing. With increase in arc discharge current, the contact weld occur more frequently, especially when loaded with an large inrush current by the effect of capacitive or lamp load and an inrush current as large as exceeding the allowable capacity of the relay employed.

To extend the contact welding life to secure an stable expected contact life, a large contact force and an adequate contact follow are required.

2.1.4.3 Operate voltage and release voltage

There are two methods for the testing procedure of operate and release voltage.

- 1) A method in which voltage is gradually increased or decreased,
- 2) Another method in which voltage is increased or decreased by steps.

Usually, in the method 2), the operate voltage tends to be smaller and the release voltage larger.

The standard level of operate voltage is 60 to 80% of the nominal voltage of coil so that relays are able to perform their function even if a small fluctuation occurs in ambient temperature, supply voltage, and resistance and voltage drop of winding circuit.

The standard release voltage is 5 to 10% of nominal voltage, considering the dark current in winding circuit.

All the relays operate at a voltage between operate and non-operate voltages and are released at a voltage between hold and release voltages.

The variation of operate and release voltages of each type of relay is described in each appropriate catalog.

2.1.4.4 Relay's temperature rise and operating temperature range

(1) Temperature rise

The relay is heated by the effect of current flows through exciting coil and contact spring, causing temperature rise in component parts. The largest temperature rise occurs in winding. Fig. 2.5 shows the relationship between temperature rise and time in winding.

An example of temperature rise in a steady state at constant supply voltage is shown in Fig. 2.6. This temperature rise per unit power is called thermal resistance of relay. The testing procedures for the thermal resistance and temperature rise are specified in IEC Publication 255-7 Electrical Relays Part 7.

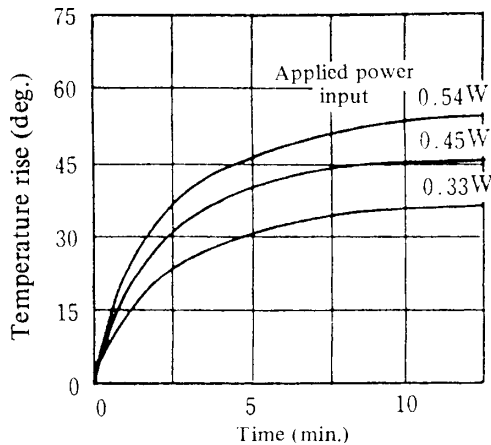

Fig. 2.5 Coil temperature rise (Time characteristics, MZ Relay)

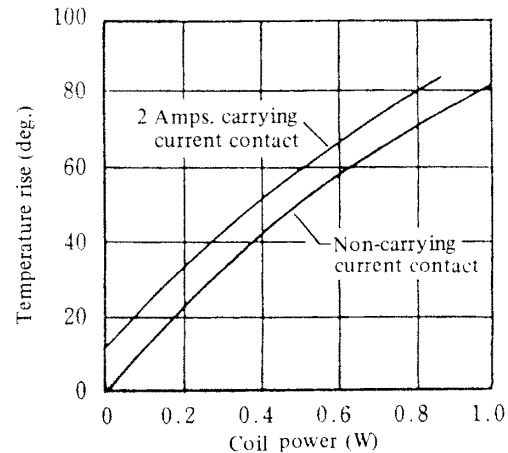

Fig. 2.6 Coil temperature rise (Power characteristics, MZ Relay)

(2) Operating temperature range

The operating temperature range of relay is defined on the basis of the following two factors:

One is the relationship between the allowable applying temperature range of contact spring and organic insulation materials used in magnet coil wire, spool, etc. and their temperature rise of the effect of currents of winding and contact spring.

The other is the boundary temperature, beyond which the relays don't operate due to increase in their coil resistance caused by temperature rise.

Concerning the former factor, the relationship between the kind of magnet wire insulation material and the allowable temperature is shown in Table 2.4. The magnet wire used in the general relays is the polyurethane wire class E with an allowable temperature of 120°C. For the relays requiring on allowable temperature higher than that, other adequate kinds of wire should be selected.

Table 2.4 Type of insulation materials and permissible temperature

Type of insulation	Maximum permissible temperature (°C)	Coil insulating material
Type Y	90	
Type A	105	Polyvinyl formal oil enamel
Type E	120	Polyurethane
Type B	130	Polyester
Type F	155	Polyester (Special)
Type H	180	Polyimide
Type C	Above 180°C	

As to the organic materials, the most popular material is the glass fiber reinforced polycarbonate or PBT, whose allowable temperature is about 120/130°C. The contact springs and contacts have also a proper allowable temperature and an allowable current depending on their dimensions, respectively. The currents larger than that cause degradation in properties. The upper limit of operating temperature based on these materials varies depending on the level of applied power input. In the lower temperature range, usually used relays are applicable with no troubles up to -40°C.

2.1.4.5 Hot coil and cool coil

Sometimes occurs such a case where, after a relay coil is energized at an ambient temperature T ($^{\circ}\text{C}$), the coil is allowed to be heated up and, upon reaching a temp. of $(T + t)$ ($^{\circ}\text{C}$), the coil is deenergized and the relay is immediately actuated to enter into operation. In this case, however, if the coil is allowed to be heated up to an extremely high temp., it may occur that the relay does not start operation when a voltage equivalent to that taken just before the coil is energized at T ($^{\circ}\text{C}$) is applied.

This is, in fact, caused by the increase in coil resistance so that an additional voltage is required to have the relay operated securely.

A coil status, such as described above, observed just after being deenergized upon reaching a significantly high temperature by energizing is called "hot coil". On the other hand, a coil status standing at a temperature similar to ambient temperature is called "cool coil". The pickup voltage of hot coil is higher than that of cool coil.

2.1.4.6 Ambient temperature and allowable winding voltage

(1) Maximum and minimum allowable voltage graph

The current flow through magnet coil, as described in Section 2.1.4.4 (1), works to raise the temperature of winding; therefore, for the practical use, the specification of coil's maximum allowable temperature range is needed, which leads, in turn, to specification of the max. allowable voltage and, in its turn, max. allowable power, which depend, however on ambient temperature, too.

With increase in ambient temperature, the coil temperature rise shifts to higher levels so that the relay must operate voltage is raised as well.

As a result, the coil's minimum allowable voltage and, in its turn, allowable minimum power are also required to be raised. The graphs representing these interrelations are collected in the catalogue: "The characteristics of ambient temperature vs max. allowable voltage and operating voltage".

The max. and min. allowable voltages can be calculated by use of these graphs.

As an example, the interrelations of LZ type relay shown in Fig. 2.7 will be described below.

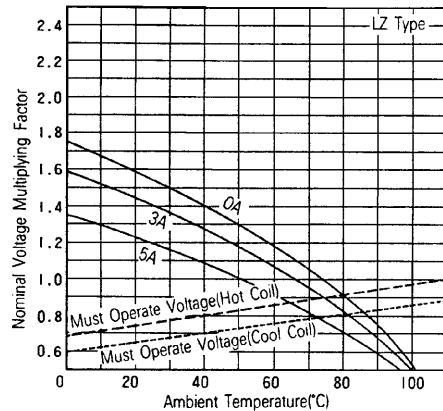

Fig. 2.7 Ambient temperature & maximum allowable voltage (LZ Relay)

The abscissa represents ambient temperature and the ordinate ratio of applied voltage to nominal one.

The curves running from the upper left to the lower right show the relay maximum permissible voltage at each ambient temperature for three types of contacts, no load contact, 3 A load contact and 5 A load contact. The relay must be used below the voltage values shown in these curves at each ambient temperature. Furthermore, the two broken lines running from the lower left to upper right show minimum responding voltages for cold and hot coils at each ambient temperature. For relay setting, voltages greater than those indicated by these broken lines must be supplied to the coil at each temperature. As a result, the relay must be used within the range bounded by one of the three curves (according to whether relay has an exciting contact or not) and the two broken lines.

(2) Long-term continuous energizing

The relays used in power supply monitoring circuit and warning circuit are sometimes placed in an energized state for a long period of time with no interruption. Continued holding at a high temperature for a long time may cause degradation in quality of material, leading to shortening of life.

For such cases, the following countermeasures are recommended:

- 1) Selection of as low ambient temperature as capable
- 2) Use of a high sensitivity relay

The power demand of this type relay is small in general.

- 3) Connection of a resistance to relay winding in series. However, securing of operate current is required. This method is applicable when the operate voltage is enough small than supply voltage.
- 4) Connection of a zener diode to relay winding in series. The purpose is the same as that of 3).
- 5) Connection of a circuit composed of parallel connection of a pair of capacitor and resistance to relay winding in series. The charging current into capacitor is used when relay is operate, and the current flowing via resistance used to hold the operation after operate. Be careful that the relay sometimes does not function if, after restoring, set again before capacitor finishes discharging.
- 6) Use of latching relay. No need of energizing after operation is finished. No heat generation. Effective for power saving.

2.1.4.7 Operate time and release time

The operate time varies depending on the applied power to coil and the resistance of winding circuit. Fig. 2.8 shows an example of the operate time vs applied power.

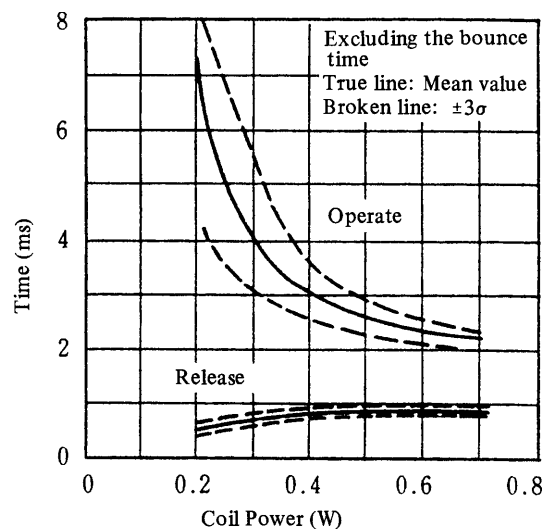

Fig. 2.8 Operate and release time

The release time, which is shown together in Fig. 2.8, varies just a little with change in applied power.

There are strict specifications for operate and release times in the sector of communication apparatuses such as tele phone exchange equipment while the general power relays do not demand very severe operating time.

As to the contact bounce of relays, its duration time depends virtually on the kind and structure of relay. It is relatively small in the recent sub-miniature relays.

Usually the contact bounce is not included in operate and release time but, if required to be included, the description of that effect is attached.

The testing procedures for operate, release and contact bounce times are specified in IEC Publication 255-7 Electrical Relays Part 7.

2.1.4.8 Dielectric strength and insulation resistance

(1) Characteristics of relay

As to specifications of dielectric strength and insulation resistance of relays, the items to be prescribed are as follows:

- 1) Between open contacts
- 2) Between adjacent two contact pairs, for each adjacent contact pair, when several contact units are mounted in one relay.
- 3) Between coil terminal and contact terminal
- 4) Between ground terminal and coil terminals as well as ground terminal and contact terminals

The fact that all the abovementioned items concerning dielectric strength and insulation resistance are ranked at a high level, respectively, is one of the features of the relay.

The dielectric strength between the terminals mentioned in the above items 1) to 4) are the very mandatory items specified in FCC (Federal Communications Commission, U.S.A.) Standards, Part 68. The types of relays complying with this Standards are listed in the catalog.

To be worthy of special mention, some relays are equipped with a contact with as high a dielectric strength between coil and contact terminals as able to withstand a impulse voltage of around 10 kV, which therefore, if used in combination with a semiconductor, can even protect the semiconductor from a lightning surge voltage.

As for the evaluation of dielectric strength, there are two kinds of testing method: test by means of a sine wave voltage of 50 or 60 Hz and a pulse voltage similar to lightning surge voltage. Those methods are called dielectric test (commercial frequency dielectric strength) and impulse voltage test, respectively.

(2) Dielectric strength at commercial frequency

This is the voltage that the relay must be able to withstand without dielectric breakdown when a specified AC voltage (50/60 Hz) is applied for 1 min. (Japanese Industrial Standards permits, as a substitution, to apply a test voltage of 110% of the 1-min. voltage for 1 sec.) between the terminals mentioned in Item (1), where the standard maximum leak current is 5 mA while there is an exception of 1 mA for special use. The format of test conditions to be described in catalog, etc. is, for instance, "Min. 1,000 VAC 1 min."

(3) Dielectric strength at impulse voltage

This is the peak value that the relay must be able to withstand without dielectric breakdown when, based on the testing method specified in IEC Publication 255-5 Electrical Relays Part 5, a specified pulse voltage with $T_r = 1.2 \mu\text{s}$, $T_t = 50 \mu\text{s}$ in a wave form as shown in Fig. 2.9 is applied between the terminals mentioned in Item (1).

Take care, however, that the wave form of impulse voltage specified in FCC Standards is $10 \times 160 \mu\text{s}$. An expression of $(1.2 \times 50) \mu\text{s}$ described in the column of surge strength in catalog indicates the time lengths T_r and T_t in a pulse wave diagram as shown in Fig. 2.9.

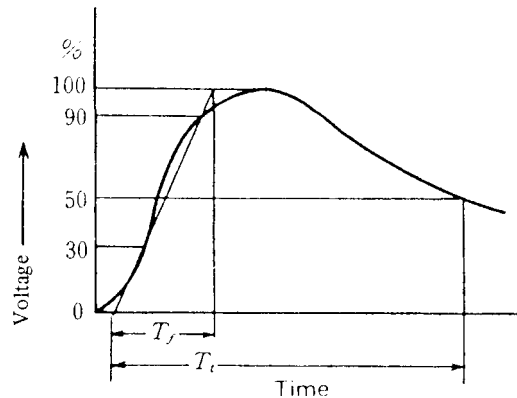

Kinds of wave form	T_r	T_t
A	$1.2 \mu\text{s} \pm 30\%$	$50 \mu\text{s} \pm 20\%$
B	$10 \mu\text{s} \pm 30\%$	$160 \mu\text{s} \pm 20\%$
C	$10 \mu\text{s} \pm 30\%$	$700 \mu\text{s} \pm 20\%$
D	$100 \mu\text{s} \pm 30\%$	$700 \mu\text{s} \pm 20\%$

Fig. 2.9 Testing wave form of surge-resistance voltage

(4) Insulation resistance

This is the insulation resistance between the specified conductors insulated with insulating material, and the values as reliable as passing the test conducted by applying 500 VDC between the terminals mentioned in Item (1) are listed in the catalog.

This value changes depending on temperature and humidity, being lowered with increase in humidity. The values listed in catalog are those at standard conditions (temp.: $20 \pm 15^\circ\text{C}$, rel. humid.: $65 \pm 15\%$). This conditions are also listed together in catalog. General relays have an insulation resistance of at least 1,000 MΩ.

2.1.4.9 Characteristics for environments

(1) Ambient temperature and humidity

The tests of general relays are conducted under the following test conditions in various environments such as at high humidities and high/low temperatures.

These tests are based on the testing procedure specified in both IEC Publication 255-7 Electrical Relays Part 7 and Japanese Industrial Standards JIS C 5442.

1) Cold

No abnormality is permitted when contact resistance, operate and release voltages, insulation resistance, etc. are tested after sample relays are kept in a thermostatic chamber of $-40 \pm 3^\circ\text{C}$ for 1,000 consecutive hours without energization.

2) Heating

No abnormality is permitted when contact resistance, operate and release voltages and insulation resistance, etc. are tested after sample relays are kept in a thermostatic chamber of $85 \pm 2^\circ\text{C}$ for 1,000 consecutive hours without energization.

3) Thermal shock

No abnormality including mechanical damage is permitted when insulation resistance, dielectric strength, operate and release voltages, operate and release times, and contact resistance are tested after sample relays are subjected to 100 cycles of heat shock loop of $-40^\circ\text{C} \times 1 \text{ h} + 20^\circ\text{C} \times 5 \text{ minutes max.} + 85^\circ\text{C} \times 1 \text{ h} + 20^\circ\text{C} \times 5 \text{ minutes max.}$

4) Damp heat

No abnormality is permitted when contact resistance, operate and release voltages, operate and release times, dielectric strength and insulation resistance are tested after sample relays are held at a temperature of $40 \pm 2^\circ\text{C}$ and a humidity within 90 to 95% for 1,000 hours.

5) Temperature-humidity loop test

No abnormality is permitted when contact resistance, operate and release voltages, operate and release times, dielectric strength and insulation resistance are tested after sample relays are subjected to 10 cycles of a specified loop of temperature/humidity combination of $65^\circ\text{C} \times 90 \text{ to } 98\% + 25^\circ\text{C} \times 80 \text{ to } 98\% + -10^\circ\text{C}$.

(2) Ambient atmosphere

Dust, oil mists, organic and inorganic gases produce adverse effects on relays such as increase in contact resistance and contact erosion.

Therefore, careful selection of relays is required for use in an atmosphere containing plenty of dust and/or gases and, if for use in an extremely contaminated atmosphere, sealed type relays are recommended.

However, even a plastic-sealed relay may cause an operational malfunction as nitric acid produced by nitrogen oxides generated by arcing and moisture causes damage to metal parts when the relay opens and closes under load, which is apt to produce arcing under condition of high humidity. In such a case, use a contact spark quenching device as shown in Fig. 2.3 in section 2.1.4.1.

(3) Vibration and shock

The use of relays is versatile, including relays used in rooms of buildings and those in circumstances subject to vibrational motion such as vehicles, vessels and aircrafts. Concerning the influences of vibration, the vibrational circumstances can be classified as shown in Table 2.5, which is the classification pattern by Japanese Industrial Standards JIS C 5002 (3).

The troubles arising from these circumstances are the contact chattering caused by vibration and the mechanical damage to mechanism resulting from accumulated fatigue of parts caused by vibrations continued for a long period of time. The data concerning these two items are listed in each catalog.

The most significant cause of those troubles is the resonance of contact spring and other parts. These component parts are, however, sufficiently resistant, including resistance of mechanical damage, to general vibrational motion, i.e. the frequencies under that of resonance. The resonance frequencies of general relays are larger than 200 Hz.

Table 2.5 Classification of environments relating to vibration of sub-miniature relays (JIS C 5002)

Symbol	Environment	Test vibrational frequency
A	Mainly, environment of aircraft	10 to 2,000Hz
B	Mainly, environments of land mobile equipment, marine and submarine vessels, which, however, limited to those subject to intensive movement	10 to 500 Hz
C	Mainly, environments of land and marine transportation	10 to 55 Hz
D	Environments of a little vibration	10 to 55 Hz

ENGINEERING REFERENCE

Like the effects of vibration, the troubles by mechanical shocks can be classified into two categories: malfunction due to chattering and mechanical damage due to severe shocks caused by violent movement/handling during transportation, cargo handling or other kinds of handling or accidental drop. The data concerning these two categories are listed in each catalogue like the handling of vibrational data. The acceleration of shock to the relay on a vehicle is approx. several m/s^2 in usual cases and in some special cases around $200 m/s^2$. In contrast, the accelerations as large as causing breakage of relay are far greater than those encountered in practical use.

According to drop tests from a height of 20 to 30 cm, usually terminals are subject to damage but the relay structure itself suffers no significant damage. However, a height of 50 cm or greater causes significant damage to the function of relay in most cases.

The testing procedures of vibration and shock resistances are specified in both IEC Publication 255-7 and JIS C 5442, in which forced vibrational and shock motions are applied in the 3 directions of x, y and z axes.

2.1.4.10 Relay reliability

(1) Modes of failures

The modes of failures of relay comprise those shown in Table 2.6, among which most failures are focused, in terms of frequency, on increase in contact resistance, poor electric continuity in contact and incapability of contact release.

Table 2.6 The mode of failures of relay

Parts	Stress			Failure symptoms	Mode of failures
	Status	Environment	Duration		
Contact	Voltage, Current, Surge voltage	Temperature, Humidity, Dust, Gas, External vibration and External shock	Long duration without a break, Intermittent	<ul style="list-style-type: none"> • Transfer and wear of contact metal due to arc discharge • Weld and bridging of contact • Sticking of contact • Corrosion (oxidation, sulfurization, etc.) • Foreign matter (dust, etc.) • Deposits 	<ul style="list-style-type: none"> • Poor release (welding, locking) • Poor contact • Increase in contact resistance • Noise • Change in operate/release voltage and operate/release time • Poor dielectric strength
Winding	Ditto	Ditto	Ditto	<ul style="list-style-type: none"> • Corrosion • Galvanic corrosion • Foreign matter (dust, etc.) • Voltage fluctuation • Vibration of lead wire 	<ul style="list-style-type: none"> • Breakage of coil, short-circuit of coil • Burning of coil • Poor working release operation • Change in operate/release voltage • Change in operate/release time Beat • Malfunction
Structural parts (Spring, sliding parts, insulations, other structural parts)	Ditto	Ditto Excessive external shock	Ditto	<ul style="list-style-type: none"> • Slip-off and wear of contact piece • Fatigue and creep of spring • Abnormal wear and loosening • Seize • Deterioration of organic material • Deposition of worn contact material powders • Corrosion and galvanic corrosion • Foreign matter (dust, etc.) 	<ul style="list-style-type: none"> • Poor contact • Poor release operation • Change in operate/release voltage • Change in operate/release time • Degradation in insulation resistance • Poor dielectric strength
Enclosure		Ditto Chemicals	Ditto	<ul style="list-style-type: none"> • Damage by external force • Change in chemical properties 	<ul style="list-style-type: none"> • Damage

(2) Reliability test

In this test, usually the switching operation is continuously repeated under a selected load and the increase in contact resistance and the contact welding failure are checked at each switching operation.

It is usual that the switching operation under as large a voltage and current as causing an intensive arc discharge works to result in cleaning of contact, thus a desirable low frequency of failures.

Under a load of 100 mA or less, the average failure rate over the whole life of contact is 10^{-6} to 10^{-10} at the 60% confidence level. Under a current load of 0.5 A or greater, decrease in the level of this rate is expected.

2.1.4.11 Life

(1) Mechanical life

In the mechanical endurance test, the relay performance is tested by continuous switching operation with no contact current load.

The major causes of life-end are the degradation in contact performance due to the deposition, on contact surface, of powders produced as the effect of wear of contact actuating card and stud or oxide of metal powders produced by the collision and rubbing motion of movable parts, and the change in operate and release voltages, contact gap and contact force.

(2) Electrical life

In the electrical life test, switching operation is repeated with a current load on contact. The life-end is when the relay has lost its proper function.

The causes of life-end are as follows:

1) Contact failure

- Reduction in contact force due to contact erosion.
- Deposition of powders caused by wear of organic materials of contact actuating card and stud on the contact surfaces.
- Deposition, on contact surfaces, of oxide of powders caused by collision and rubbing motion of movable parts and powders produced by erosion of contact metal.
- Deposition, on contact surfaces, of carbides produced by dissolution of organic gases adsorbed onto the contact surfaces.

2) Welding and bridging of contact

Welding of contact occur at the instant of contact closing by the effect of a large current arc discharge accompanied with bounce of contact. It also causes transfer of fused metal, leading to formation of a projection and, as a result, a bridging of contact.

3) Defective insulation

The deposition of scattered worn-contact metal powders on the surface of insulations causes reduction in their insulation resistance and dielectric strength. Also, the degradation in insulation resistance occurs due to local burning of insulations caused by a large amount of heat from arc discharge.

4) Others

The deviation of operate and release voltages, contact gap and contact force from their specified ranges effects life-end.

(3) Relationship between life and switched contact voltage/current

Generally, the contacts are provided with a form and dimensions safe enough to avoid erosion and transfer failures at least until the life-end listed in respective catalog.

Therefore, the electrical life listed in each catalog are those under the load conditions described together. If a contact load actually applied is smaller than that in catalog, the life of the contact will be extended. Examples of relationship between life and contact voltage/current are shown in Fig. 2.10 and 2.11, in which Fig. 2.10 is for DC load and Fig. 2.11 for AC load. The relationship of switched contact current vs life is expressed by a straight line with a gradient of about 45°.

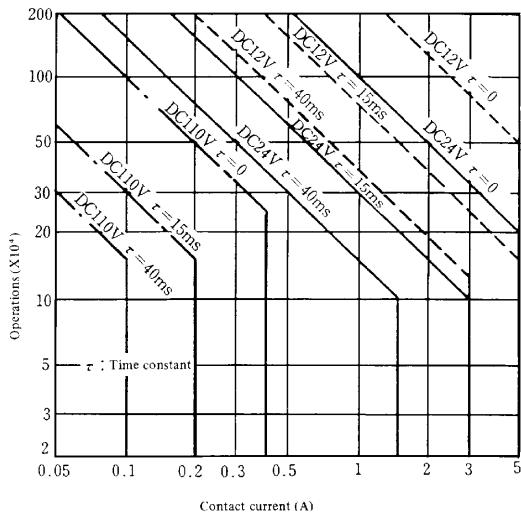

Fig. 2.10 Life curves (DC) (JY type, AgCdO contact)

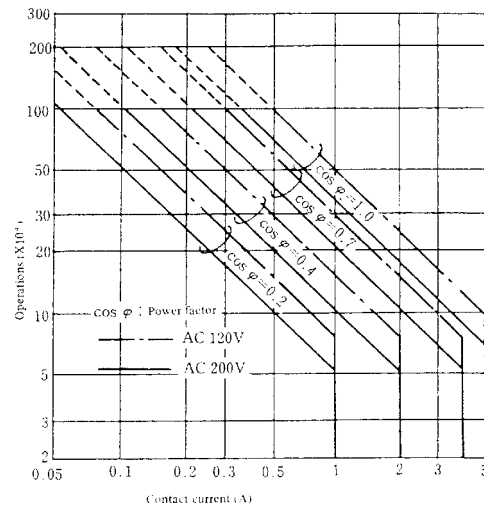

Fig. 2.11 Life curves (AC) (JY type, AgCdO contact)

Both Figs show inductive loads, too, with the time constant or power factor and voltage of load as parameters. These figures indicate that:

- 1) The guarantee of a life (in number of switching operations) in inductive load equivalent to that in resistive load results in that the allowable voltage/current in inductive load is smaller than that in resistive load.
- 2) If assumed that the contact voltage/current in inductive load is the same as that of resistive load, the number of switching operations until the life-end is smaller in inductive load than that in resistive load.

The selection of relays having a life matching the requirements of equipment for use is important. If a specially large number of switching operations is required, the use of socket (receptacle) is useful because the change of relay is easy.

(4) Overload

Overload test is the contact load switching test for evaluation of surplus ability against the rated load of electromagnetic relay. This testing procedure is specified in both IEC Publication 255-7 and JIS C 5442.

2.1.5 Industrial standards and safety standards

2.1.5.1 Industrial standards

Among international standards concerning relays is IEC (International Electrotechnical Commission) Standard. Many of its publications, which are mentioned below, issued in parts including that of testing procedure are procurable separately. At present, a subcommittee of IEC is working to still more improve its quality, IEC Publication 255 "Electrical relays" series.

In Japan, there are many standards concerning relays including those which are given a title containing a word of 'relay'. The individual books of JIS (Japanese Industrial Standards) containing a word of relay in their title are as follows:

JIS C 4523 'Control Reed Relays'

JIS C 4530 'Hinge Type Electromagnetic Relays'

JIS C 5442 'Test Methods of Low Power Electromagnetic Relays for Industrial Control Circuits'

There are also other standards concerning relays issued from 'Nippon Electric Control Equipment Industry Association and other institutes or organizations.

2.1.5.2 Safety standards

Laws and regulations demand securing the safety of users from dangers such as electric shock and fire lying around household appliances and other consumer electric equipment or devices.

Major industrial countries across the world already have their own safety standards such as those under control of 'The Electrical Appliance and Material Control Law' in Japan, UL in U.S.A., CSA in Canada, VDE in Germany, SEMKO in North Europe and BS in GB, and the relays for use in consumer products such as household devices, automatic vending machines and business equipment are required to comply with each country's safety standard.

As to 'the Electrical Appliance and Material Control Law', the relay as an appliance is not included in either category of class-A and class-B electrical appliances of this Law so that the type approval by the Law does not apply to the relay itself. The Law, however, applies to each assembly with a relay as a component part so that the relay must be equipped with as high a level of technology as meeting the technical level specified in that Law.

The major items to be evaluated by the Law are as follows:

- 1) Temperatures of contact and coil
- 2) Dielectric strength between conductors
- 3) Insulation resistance between conductors
- 4) Insulating distance between conductors (space distance and creeping distance)

In U.S.A., consumer products must conform to UL (Under Writer's Laboratories Inc.) standards so that the relays intended for rule in U.S.A. are required to acquire the approval of UL. The type of relay authorized by UL is announced publicly for convenience of users.

For evaluation of technical level, besides the test items specified in the abovementioned Law, there are standards for material test, electric endurance test and over load test. In UL standards, test conditions are different among categories. The TV rating is a good example. It was established in 1970, making an event of TV fire an occasion. This TV rating is a very severe one, demanding for the outside materials to have both the self extinguishing and arc-proof properties and for the electric endurance test and over load test to use a huge inrush current as a test load, where an inrush current is specified for each rated current. The products approved after the testing based on this TV rating are permitted to carry a mark of TV-5 and a display of approved current level.

CSA (Canadian Standards Association) is given by a Canadian law the authority of establishment of standards and qualification of products. The products intended for export to Canada are required to be approved by CSA and carry the mark of 'CSA'. The technical level demanded by CSA is almost the same as that by UL. The CSA TV rating has been enforced since 1971.

ENGINEERING REFERENCE

The UL and CSA TV rating has a system of approval ranking. The rank of each type of our relay is shown in Table 2.7.

Table 2.7 TV rating recognized relay type

TV Rating	TV-3	TV-5	TV-8	TV-10	TV-15
Relay type	FTR-F1 FTR-F4 VB	FTR-F2/H2 FTR-H1 VR	FTR-K1 VS	FTR-K3	VF

In Germany, VDE (Verband Deutschen Elektrotechniker e.v.) has the authority concerning safety. German safety standards are rated high worldwide. In Germany, it is established by a law that the products approved by VDE can receive immunity from responsibility even if they are a cause of an electric shock or fire accident. Other countries' standards are also similar to the above ones in character.

2.2 RECOMMENDATION AND PRECAUTION

2.2.1 Silicone compound should be avoided

Products containing silicon are widely used as silicone rubber, insulation material, paint, etc., since they have excellent electric insulation, heat and cold resistances. If, however, any material containing silicon is used in the neighborhood of relay, the silicon gas emitted from that material penetrates into the interior of relay and the silicon oxides produced by the effect of arc discharge at contact are deposited on the contact surfaces, which brings, after all, contact failures. Thus, be sure to keep silicone compounds apart from relays.

2.2.2 Strong magnetic field can cause disorder of operate and release voltages

The strong magnetic field generated from the equipment with electro-magnetic appliance such as transformer and speaker, arranged near a high sensitivity or polarized relay, can cause disorder in operate and release voltages of the relay. In such a case, suitable measures such as magnetic shielding or selection of adequate location/orientation in arrangement of relay should be taken to protect relays from malfunctions.

2.2.3 Guide for connection of load

• AC circuit is better for switching of load:

Generally, in DC load that never takes zero potential unlike AC load, the once generated arc discharge lasts for a relatively long time and the load-cutting control capacity is smaller compared with that in AC load. Moreover, in DC load, the contact life shortening events caused by contact metal transfer or the like occurs more often.

Therefore, if both of AC and DC circuits are available for switching of load as shown in an example of Fig. 2.12, the switching by AC circuit is desirable from the standpoint of life.

• Parallel connection of loads and contacts:

Loads and contacts should be connected with the same polarity of their power sources arranged on the same side as shown in Fig. 2.13 (a). If, to the contrary, reversed between them as shown in Fig. 2.13 (b), there is a fear of short-circuit between the power sources of adjacent two contacts. If the reversed arrangement is inevitable, use a multi-contact relay such as FRL-230 type relay to secure a larger distance between two adjacent contacts by arranging a dead contact between them.

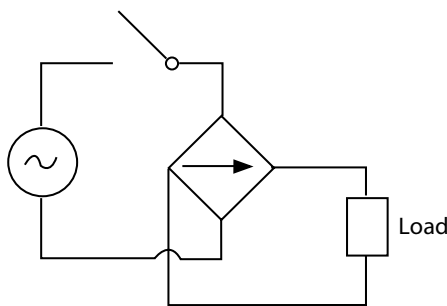

Fig. 2.12 AC circuit is better for switching of load

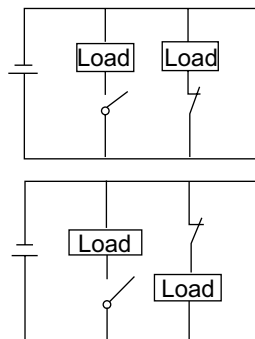

Fig. 2.13 Parallel connection of load and contacts

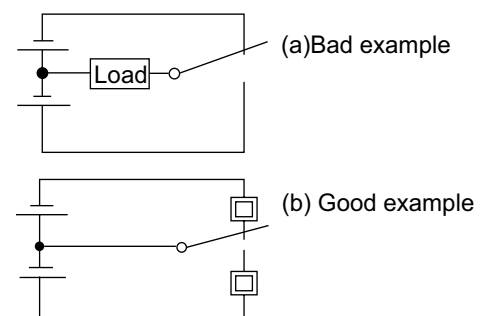

Fig. 2.14 Load share and division

• **Division of load:**

If a load is shared in a manner as shown in Fig. 2.14 (a), an arc discharge may cause a short-circuit between power sources, leading to burning of contact. The recommendations for such a case is division of load, as shown in Fig. 2.14 (b), or insertion of a resistance.

• **Short-circuit between contacts:**

At a transfer contact, in principle, the make contact is closed after the break contact is opened. However, there is a fear of short-circuit between make and break contact due to arc discharge. However, in a circuit as shown in Fig. 2.15 (a), there is a risk of formation of such a short circuit as a loop of a-b-c if an event of 3-point contact occurs at c. In the same way, in Fig. 2.15 (b), a short circuit as a loop of d-e-f if 3-point contact occurs at f. Be sure to avoid such connections.

• **Polarity switching in motor:**

When change of rotary direction of a running motor is attempted, such a connection as shown in Fig. 2.16 (a) will make the power supply circuit shorted in the cause of ionization of the air in the vicinity of contact by the effect of arc discharge at contact, resulting in damage to contact.

It is, therefore, necessary for reversing the direction of rotation to adopt a circuit as shown in Fig. 2.16 (b) so as not to be switched before arc is extinguished.

It is desirable to avoid switching of two extremely different loads, such as a combination of large and micro current loads, in the same relay. Products such as carbon powders produced when a large current load is switched can be deposited on the contact faces of micro current load switching contact, leading, after all, to contact failures.

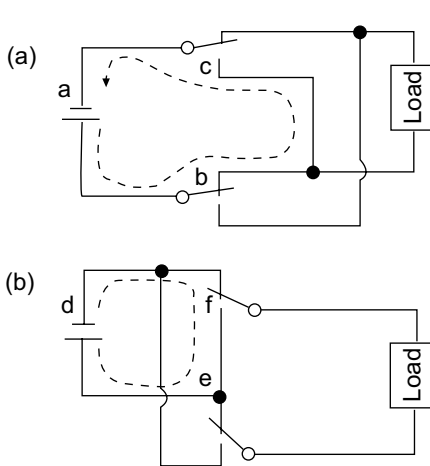

Fig. 2.15 Short-circuit between contacts

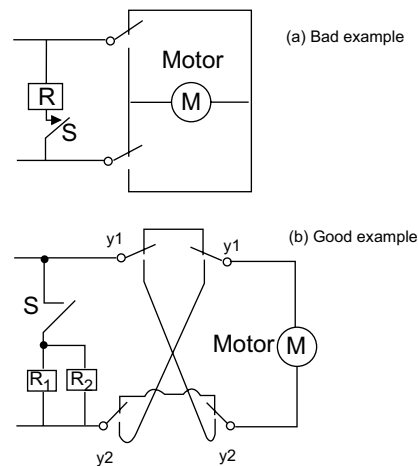

Fig. 2.16 Polarity switching in motor

2.2.4 Precautions for mounting of relay

2.2.4.1 Schematics and PC board mounting hole layout

Schematics and PC board mounting hole layout are inserted in the catalog for the instruction of printed circuit board relays, which are those viewed from the back side of printed circuit board (the side opposite to the relay mounted side) for through hole relays, and are those viewed from the top side of printed circuit board for surface mount relays.

2.2.4.2 How to use socket

- 1) The relay should be inserted into or removed from receptacle always perpendicularly to the face of receptacle. If not perpendicular but aslant, terminals may be bent, causing poor contact with receptacle and thus its contact failures.
- 2) If considered a fear of loosening in coupled relay and receptacle, be sure to use a fixture attached to the receptacle.
- 3) Be sure to deenergize the receptacle before insertion or removing of relay to avoid the danger of electric shock and damage to equipment.
- 4) The use of receptacle is helpful for maintenance of relay. Be careful, however, not to change the type or kind of relay by mistake when replacement is required.

2.2.4.3 Others

- 1) Be careful that a large shock, e.g., caused by accidental drop may degrade the performance of relay. If having dropped accidentally, be sure to check for performance before mounting.
- 2) Be careful that machining of panel with a relay mounted on it can cause chips to enter the interior of relay, leading to malfunction on contact failure. The same troubles may occur if holes are drilled in a printed circuit board with a relay mounted on it.

2.2.5 Transistor driver

2.2.5.1 Relay driver

Fig. 2.17 shows a standard circuit for relay driver used transistor.

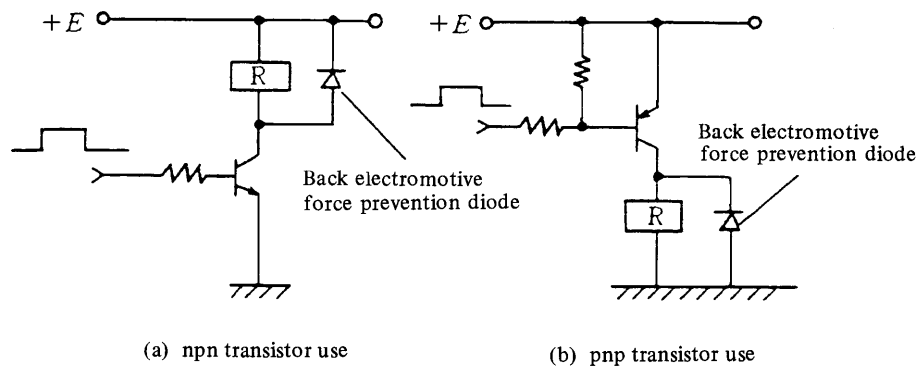

Fig. 2.17 Standard circuit for relay driver used transistor

2.2.5.2 How to select transistor

- (1) Determination of voltage and current to be applied to coil of relay
 - 1) See the catalog and select the type of relay and the nominal voltage of its coil to be used.
 - 2) Considering the allowable fluctuation in power supply, determine a maximum voltage and current to be applied to the coil at a max. ambient temperature, which constitute the worst conditions of allowable collector loss of transistor.
 - 3) Determine a max. coil current at the lowest ambient temperature, which is the max. level of collector current.
 - 4) Assure that the voltage to be applied to coil at the highest ambient temperature exceeds the operate voltage of the relay.
- (2) Selection of transistor
 - 1) The dielectric strength of transistor must be at least two times the voltage of power source.
 - 2) Select a switching transistor with a collector current at least two times^{*)} as large as the coil current at max. conditions.
*): Safety factor
 - 3) After determination of collector current is completed, determine the base current. The base current is required to be large enough to permit the use of transistor within an area of saturated interval between collector and emitter.
 - 4) Determine the collector loss at worst conditions. Add the base loss to this loss to obtain the total transistor loss. Assure that the value obtained falls within an allowable range in the total loss vs ambient temperature characteristic with a sufficient reserve room in that range.

2.2.5.3 Back electromotive force prevention element

A sudden shutoff of coil current causes a sharp high-voltage pulse. If this voltage exceeds the dielectric strength of the transistor for relay drive, the transistor may suffer damage or degradation in performance. Therefore, the insertion of a back electromotive force preventing element in parallel with magnet coil, as shown in Fig. 2.17 is required.

Diode, a combination of diode and zener diode, or varistor is used as a protector element in practice. As to the ratings of these elements, the average current should be the same as magnet coil current and a safe level of maximum reverse voltage is around 3 times the power source voltage.

2.2.5.4 Precautions for transistor driver

- (1) Relay drive current wave form

A large onset or downset time length in relay drive current wave causes an unstable operate or release, resulting in shortening of contact life.

To settle such a problem, insertion of a schmidt circuit in the fore stage of circuit as shown in Fig. 2.18 is recommended to reform the wave shape.

(2) Dark current

If such a circuit as shown in Fig. 2.19 (a) is selected in order to pick out another signal at the time when relay begins operation, a small dark current will remain in the relay coil even if the transistor 'T₁' is turned off. A dark current remaining in relay coil can disturb restoration of relay and cause degradation in vibration and shock resistances. A modified circuit as shown in Fig. 2.19 (b) is recommended to settle such a problem.

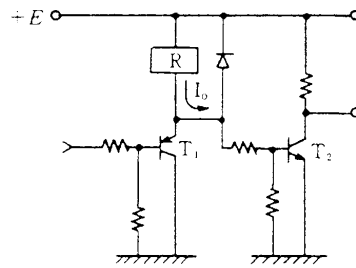
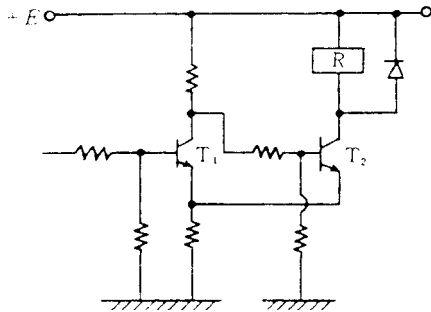

(a) Bad example

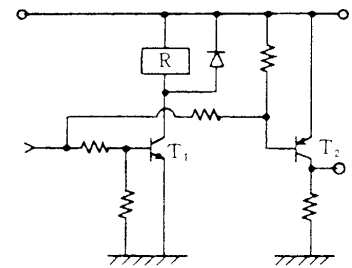

(b) Good example

Fig. 2.18 Schmitt circuit to reform wave shape

Fig. 2.19 Circuit for protect dark current

2.2.6 Check of contact for synchronization with AC load phase

If a half-wave rectified current is used as a relay energizing current when a contact load comprises an AC load, the timing of operate and release of relay is liable to synchronize with the phase of load, as shown in Fig. 2.20. In some relays, their contacts switch the AC load in the vicinity of a peak level of that load current and in some other relays only in the vicinity of zero level so that, at shutdown of current load, a large current arc discharge lasts for a long time in some relays but not in other relays, thus resulting in large dispersion of life among relays.

Even an full-wave rectification with no smoothing capacitor can cause a similar phenomenon so that it is recommended to use as large a capacity of smoothing capacitor as capable to reduce the pulsation.

Be careful that a similar phenomenon occurs if the switching operation of contact synchronizes with the AC load phase even if a energize power source with a small level of pulsation is used.

A random-phased switching operation is desirable. By the way, if synchronization is permitted, the contact switching timing should be adjusted so as to coincide with the timing of AC load just crossing zero level; if so, a long life of relay will be expected.

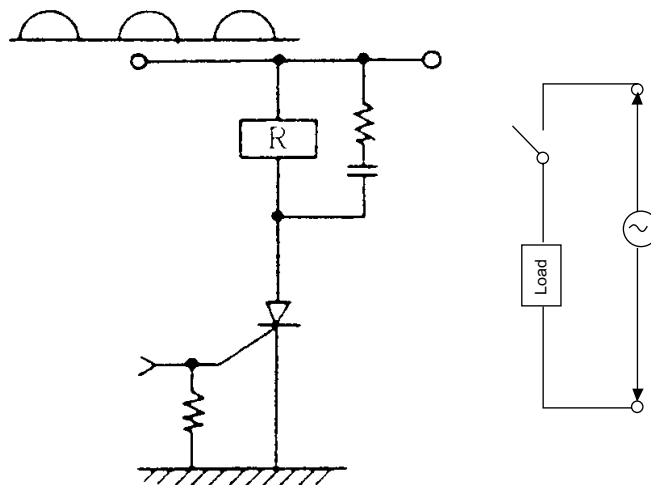

Fig. 2.20 Check of contact for synchronization with AC load phase

2.2.7 Usage of latching relay

2.2.7.1 Example of latching relay driver

Fig. 2.21 shows an example of latching relay driver, in which an AC half-wave is used for drive of a non-polarized latching relay.

In Fig. 2.21, if an optimum level of resistance is given to current limiter resistances R_1 and R_2 , respectively; this circuit can be used as a drive circuit for one-coil type polarized latching relay and, if an independent coil is provided to each of 'I₁-coil' and 'I₂-coil' in the Figure, this circuit can be used as a drive circuit for two-coil type latching relay.

In this circuit, a half-wave alternate current is used for the operation and release of relay; when transistor Tr_1 is turned on, a current I_1 flows to operate the relay and, when transistor Tr_2 on, a backward current I_2 flows through an magnet coil to release the relay. Here, R_1 and R_2 are current limiters, i.e., they control the current level in a non-polarized relay so as to be larger than a release current and lower than a reoperating current.

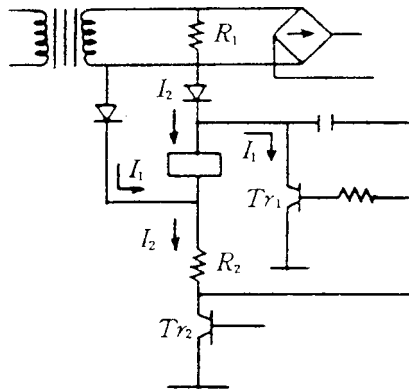

Fig. 2.21 Example of latching relay driver

2.2.7.2 Precautions for connection of latching relay winding

- 1) For winding connection of latching relay, be careful to have the polarity comply with the specification. Never have it reversed.
- 2) Avoid simultaneous application of voltage to set and reset coils. (In case of 2-coils latching relay.)
- 3) For parallel connection of coils, be sure to insert a diode.

For connection of more than one set coils or reset coils, use diode(s), arranging in series with magnet coil in a manner as shown in Fig. 2.22, to avoid malfunctions caused by back electromotive forces among coils.

The situation (i.e. measures) is the same as the above when a set or reset coil is connected in parallel with an inductive load such as other relay coil, motor and transformer, as shown in Fig. 2.23.

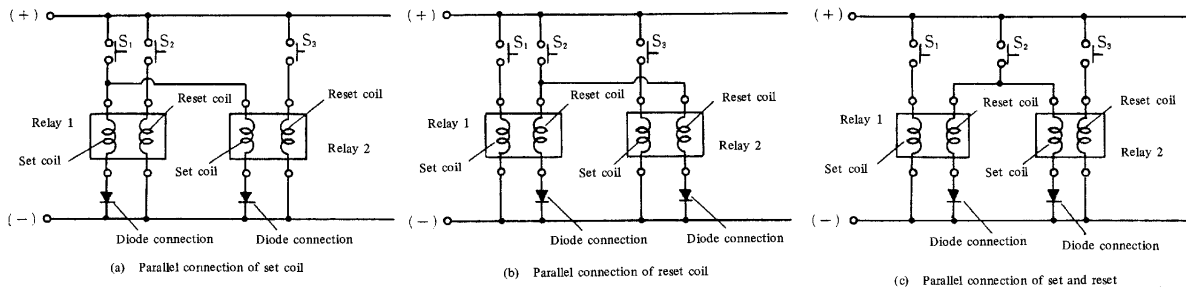

Fig. 2.22 Parallel connection of latching relay winding

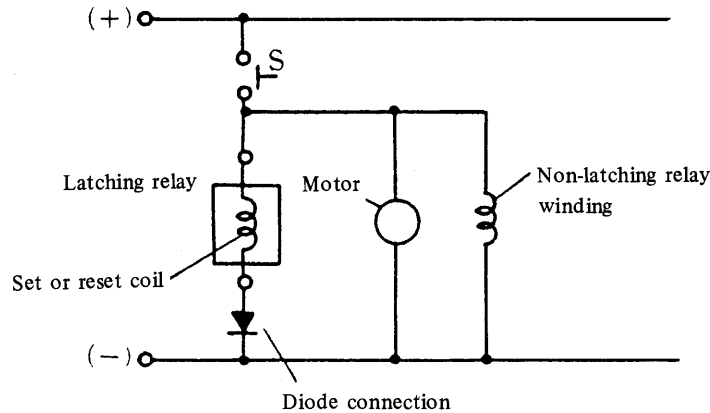

Fig. 2.23 Parallel connection of latching relay winding and inductive load

2.2.7.3 Other precautions

- 1) As to the widths and voltages of drive pulses for operate and release of latching relays, refer to appropriate catalogs.
- 2) For use in environments filled with plenty of iron or other magnetic powders, dust, etc., select adequate sealed type relays.
- 3) For use in particularly intensive magnetic field, check for the effect by using the very relay set you attempt to use. As to interrelay distances among a number of densely mounted relays, refer to the paragraph of 'Magnetic interference' in 2.2.8.1 (1) 2).
- 4) When any appliance or equipment equipped with a latching relay is completed of a final product, the first energizing of the product should be conducted with the latching relay circuit in reset state.

2.2.8 Mounting of relay on printed circuit board

2.2.8.1 Mounting of relay on printed circuit board and designing of circuit pattern

(1) High density mounting of numerous relays

1) Temperature rise

Since the temperatures of densely mounted relays are raised by the effect of mutual intervention of the heat emitted from relay themselves, check for the operation of relay through a test of actually mounted relays in minimum interrelay distance.

Fig. 2.24 shows the results of a test example on temperature rise in the relays densely mounted together, in which nine relays were arranged in matrix of 3×3 and the temperature rise of a relay positioned in the center of matrix were measured with the interrelay distances as the parameter.

Especially, care should be taken when a card rack with a lot of printed circuit boards layered is installed.

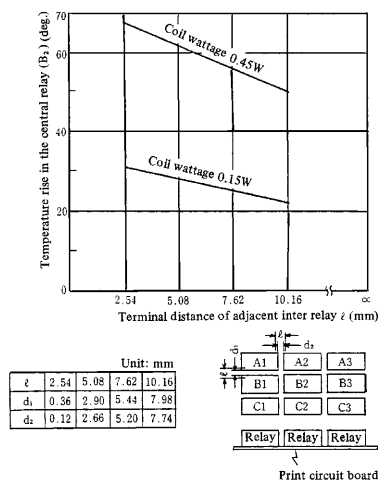

Fig. 2.24 Temperature rise in the relays densely mounted together (RY type)

2) Magnetic interference

The magnetic interference among densely mounted relays is also one of problems. An example of test results is shown in Fig. 2.25, in which the operate and release voltages of center relay in 9 densely mounted relays were measured under conditions of (a) to (g), that are expressed in percentage to those values in single mounting. Thus, the operate and release voltages, etc. are changed due to magnetic interference so that the minimum interrelay distance and mounting direction should be selected referring to the data described in the catalog for polarized relay.

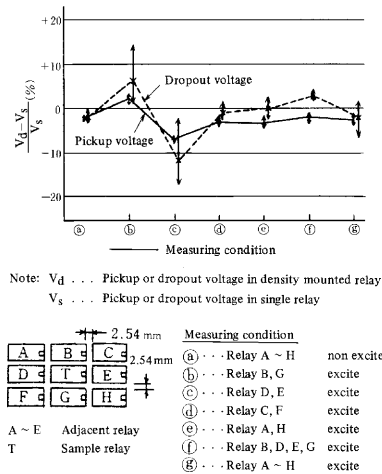

Fig. 2.25 The magnetic interference among densely mounted relays (RA type)

(2) Less-noise wiring pattern

Arrangement of any wiring pattern that must not be affected by the noise such as audio signal, in a manner as being located under the coil of relay should be avoided.

The recommendation, therefore, is the use of a relay with an exceptionally large distance between coil terminal and contact spring terminal.

A back electromotive force preventing element should be arranged as near the coil as capable to reduce the length of wiring pattern.

(3) Precautions for transportation of soldered printed circuit board

If a relay mounted and soldered onto a printed circuit board is lifted with the relay cover gripped, there is the possibility of the board slipping off by cover removing because the parts coupling the relay and cover are not always strong enough to be able to support the weight of board. Be sure to hold the board, not the relay.

Never remove the cover during transportation. If removed, the contact spring, etc. are subject to being caught by something, causing damage to the relay.

(4) Warp of printed circuit board

Avoid such assembling methods as causing warp of printed circuit board, which may lead to breakage of copper foil circuits and/or solder deposits, affecting the performance of relay.

2.2.8.2 Precautions for manual soldering

1) Use a soldering gun of 30 to 60 W, which should match the heat capacity of relay.

2) the soldering duration should be within 3 sec. for each attempt. An excessively long duration can cause separation of copper foil and damage to mold of relay, affecting the performance of relay.

3) An adequate temperature of soldering gun top end is 280° to 300°C. Never begin soldering before the gun is sufficiently heated up. A too low gun temperature often causes the flux contained in resin-mixed solder only to fuse and collect around a terminal, causing poor quality soldering.

4) It is recommended to lead the flux fumes into a duct or the like to prevent entry of the fumes into interior of relay.

5) As for coating of Cu foil with varnish, apply it limiting to the soldering side of printed circuit board only.

2.2.8.3 Precautions for automatic soldering

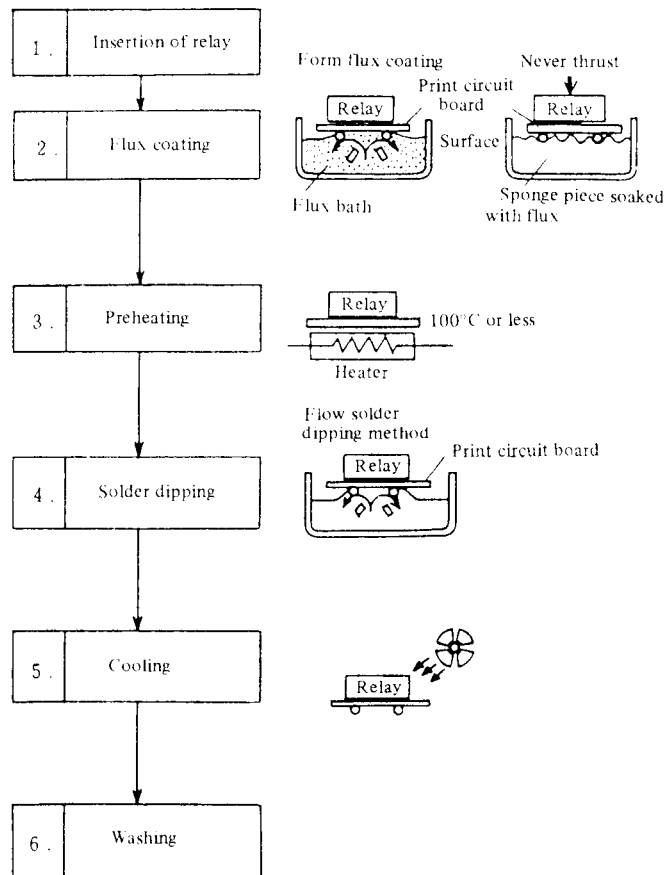

Fig. 2.26 Automatic soldering process

(1) Comply with the procedure represented in Fig. 2.26.

(2) Insertion of relay

A stick packaging system convenient for automatic mounting is prepared for some types of relays.

(3) Flux coating

- 1) Recommendable fluxes and solvents are those of rosin family and alcohol family, respectively. Alcohol is rather chemically inactive and rosin is not corrosive, needing no washing.
- 2) Using a foamed resin piece or the like, apply flux uniformly. Control the flux bath level so as to avoid flowing of flux over the printed circuit board surface to penetrate into the interior of relay.
- 3) If a sponge piece soaked with flux is used, never thrust it against printed circuit board because the squeezed-out flux may enter the interior of relay. Handling of sponge should be conducted gently. In addition, avoid direct dipping of printed circuit board in flux bath.

(4) Preheating

- 1) Be sure to make preheating after flux coating is completed. The preheating contributes to leveling the temperature distribution at dipping, resulting in good quality solder deposits, as well as to prevention of entry of flux into the interior of relay during soldering process.
- 2) The preheating temperature should be 100°C or less.

- (5) Solder dipping
- 1) Our recommendation is the adoption of flow solder dipping method represented in Fig. 2.26.
 - 2) Use the solder complying with H60 or H63 specified in JIS Z 3282. (Ratio of Sn: Pb = 60:40 or 63:37).
 - 3) An adequate solder bath temperature is 250°C ±5°C.
 - 4) An adequate dipping time is within about 3 sec.
 - 5) Control the solder bath level so as not to allow molten solder to flood the printed circuit board surface.
 - 6) The oxide film covering the solder bath surface disturbs run-up of molten solder so that the use of oxide film formation preventing device (e.g. by oil film) or the action of frequent oxide film removal is required.
- (6) Cooling
Use a blower to cool soldered assemblies immediately after completion of dip soldering process so as not to cause degradation in quality of printed circuit board, relay and other parts.

2.2.8.4 Precautions for washing (Cleaning)

There is no need of washing if rosin ester flux is used. If, however, any activated rosin ester flux is used, washing is mandatory because the activator contains corrosive chlorine and bromine.

If washing is inevitable, follow the advices presented below as to washing method and selection of washing solution so as to protect relay's cases from being damaged by washing solution as well as prevent penetration of washing solution into interior of relays:

- (1) Washing solvent:
- Recommended solvent:
Alcohol based solvent, water
 - Unrecommended solvent:
Chlorine-based solvents, Aromatic-based solvents
- Refer to Table 2.8.

Table 2.8 Recommended, Unrecommended Solvents

Recommended solvent	Unrecommended solvent
<ul style="list-style-type: none"> • Alcohol-base • Water 	<ul style="list-style-type: none"> • Chlorine-base Trichoroethylene, Chloroethylene • Aromatic-base..... Thinner, Gasoline families (Benzene, Xylene, Acetone, etc.)

- (2) Washing procedure
- 1) Flux free type
 - Wash the soldered side face only.
Gently wipe the surface. Be careful not to allow washing solution to flood the printed circuit board surface.
 - The automatic or manual wiping motion for cleaning of soldered face by means of brush soaked with washing solution should be gentle and careful so that the washing solution containing dissolved flux is not scattered or driven through holes on the front side of printed circuit board.
 - If a printed circuit board is placed directly on a sponge piece soaked with washing solution with the soldered face of board as the bottom side and, after holding for about 1 min., rubbed gently, flux will be removed easily.
 - The cleaning by whole washing is not available to flux free type relays. If whole washing is required, use the following plastic sealed (washable) type relay.
 - 2) Plastic sealed (washable) type relay
 - Immersion cleaning is available to the plastic sealed type relay mounted on a printed circuit board (including plastic sealed type relays with small holes in their cases if these holes are sealed with adhesive tape). Such cleaning solvents as listed in Table 2.8 are recommended. Use of unrecommended solvents may damage the relay case.
 - Avoid carrying out ultrasonic cleaning because there is a possibility that defects such as open coil and contact sticking may occur due to ultrasonic energy. However, if ultrasonic cleaning must be performed, contact us beforehand.
- (3) Coating of printed circuit board
When spray coating is applied to a relay-mounted printed circuit board to improve the insulation resistance of circuit patterns as well as protect them from corrosion, the bodies of mounted relay and other parts should be covered with some adequate protector to protect them from damage by coating solution and prevent penetration of it into their interior; some coating solutions are chemically active enough to damage the relay case and/or cause contact failures, especially silicone compounds, which should never be used.

ENGINEERING REFERENCE

Contact

Japan

FCL COMPONENTS LIMITED
Shinagawa Seaside Park Tower
12-4, Higashi-shinagawa 4-chome,
Tokyo 140 0002, Japan
Tel: +81 3 3450 1682
Email: fcl-contact@cs.fcl-components.com

North and South America

FCL COMPONENTS AMERICA, INC.
2055 Gateway Place, Suite 480
San Jose, CA 95110 U.S.A.
Tel: +1 408 745 4900
Email: fcai.components@fcl-components.com

Europe

FCL COMPONENTS EUROPE B.V.
Diamantlaan 25
2132 WV Hoofddorp
Netherlands
Tel: +31 23 5560910
Email: info@fcl-components.eu

Asia Pacific

FCL COMPONENTS ASIA, LTD.
No. 20 Harbour Drive, #07-01B
Singapore 117612
Tel: +65 6375 8560
Email: fcal@fcl-components.com

China

FCL COMPONENTS (SHANGHAI) CO., LTD.
Unit 1105, Central Park –Jing An, No.329 Heng
Feng Road, Shanghai 200070, China
Tel: +86 021 3253 0998
Email: fcsh@fcl-components.com

Hong Kong

FCL COMPONENTS HONG KONG CO., LIMITED
Room 13, 23/F, Seapower Tower, Concordia Plaza,
No.1 Science Museum Road,
Tsim Sha Tsui East, Kowloon, Hong Kong
Tel: +852 2881 8495
Email: fcsh@fcl-components.com

Web: www.fcl-components.com/en/

Copyright

All trademarks or registered trademarks are the property of their respective owners. FCL Components America or its affiliates do not warrant that the content of datasheet is error free. In a continuing effort to improve our products FCL Components America, Inc. or its affiliates reserve the right to change specifications/datasheets without prior notice.

Copyright ©2024 FCL Components America, Inc. All rights reserved. Revised February 1, 2024.
