

POINTING DEVICE

PALM MOUSE™

FID-824 SERIES



DISCONTINUED

FEATURES

- Hand held operation
- Long life and high reliability
 - No mechanical contact
 - Unique magnetic field detection technology
- Smooth operation
 - Light touch
 - Easy full-screen control
 - Stable operation in any direction

MAIN APPLICATIONS

- Notebook computer
- Multi-media equipment
- GPS

CONSTRUCTION

- With enclosure and interface cable

FID-824 SERIES

SPECIFICATIONS

Item		Specification
Mechanical	Detection Method	Unique magnetic field detection technology
	Number of Switches	2 buttons
	Operation Force	200 gf (7.04 oz.) typ.
	Operating Life	1 M strokes min.
	Switch Life	1 M operations min.
	Weight	30 g (1.056 oz.) typ.
Electrical	Power Supply	+5 V \pm 0.25 V DC, 20 mA max.
	Interface	Clock synchronous serial transmission (PS/2)
Environment	Operating Temperature	0 to 40 C
	Storage Temperature	-15 to 60 C
	Humidity	90% RH max. at +40 C max. inversely proportional change to 50% RH at 60 C

PARTS NUMBERS

Parts Number	Number of Switches	Interface	Connector	Color		
				Case	Cap	Switch
FID-824-511	2	Clock synchronous serial (PS/2)	Mini-DIN 6 pin	Light gray		
FID-824-512				Yellow	Green	Blue
FID-824-513				Green	Blue	Yellow
FID-824-514				Blue	Yellow	Green

CONNECTOR PIN ASSIGNMENT

Mini-DIN 6 pin

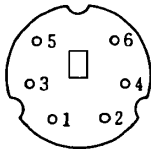

Pin number	Signal name
1	Data
2	—
3	GND (SG)
4	V _{cc}
5	Clock
6	—

FID-824 SERIES

DIMENSIONS

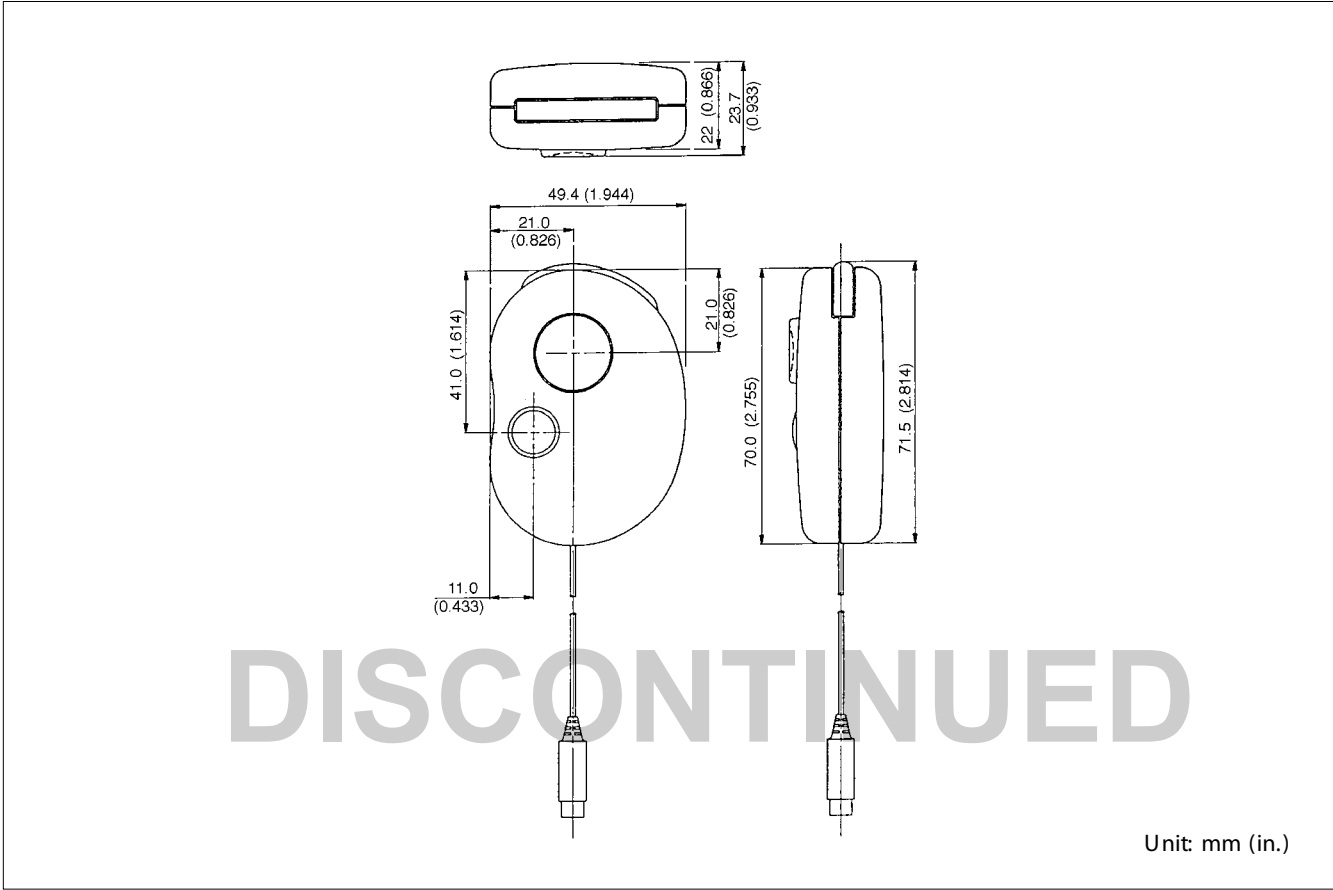

Fujitsu Components International Headquarter Offices

Japan
Fujitsu Component Limited
Gotanda-Chuo Building
3-5, Higashigotanda 2-chome, Shinagawa-ku
Tokyo 141, Japan
Tel: (81-3) 5449-7010
Fax: (81-3) 5449-2626
Email: promothq@ft.ed.fujitsu.com
Web: www.fcl.fujitsu.com

North and South America
Fujitsu Components America, Inc.
250 E. Caribbean Drive
Sunnyvale, CA 94089 U.S.A.
Tel: (1-408) 745-4900
Fax: (1-408) 745-4970
Email: marcom@fcai.fujitsu.com
Web: www.fcai.fujitsu.com

Europe
Fujitsu Components Europe B.V.
Diamantlaan 25
2132 WV Hoofddorp
Netherlands
Tel: (31-23) 5560910
Fax: (31-23) 5560950
Email: info.marketing@fceu.fujitsu.com
Web: www.fceu.fujitsu.com

Asia Pacific
Fujitsu Components Asia Ltd.
102E Pasir Panjang Road
#04-01 Citilink Warehouse Complex
Singapore 118529
Tel: (65) 375-8560
Fax: (65) 273-3021
Email: fcai@fcai.fujitsu.com
www.fcai.fujitsu.com

© 2001 Fujitsu Components America, Inc. All company and product names are trademarks or registered trademarks of their respective owners. Rev. August 20, 2009