

## **FCL Components Wireless modules**

### **Mesh Sensor Unit (Wirepas Mesh 2.4 GHz based)**

#### **FWM8BLZ08Y-109105 Datasheet**

Ver. 2  
Feb 1, 2024

---

---

The above Product is designed, developed and manufactured as contemplated for general use, including without limitation, general office use, personal use, household use, and ordinary industrial use, but is not designed, developed and manufactured as contemplated (1)for use accompanying fatal risks or dangers that, unless extremely high safety is secured, could lead directly to death, personal injury, severe physical damage or other loss (i.e., nuclear reaction control in nuclear facility, aircraft flight control, air traffic control, mass transport control, medical life support system, missile launch control in weapon system), or (2)for use requiring extremely high reliability (i.e., submersible repeater and artificial satellite), hereinafter referred to as "High Safety Required Use". You shall not use this Product without securing the sufficient safety or reliability required for the High Safety Required Use. If you wish to use this Product for High Safety Required Use, please consult with our sales representatives in charge before such use.

FCL Components Limited

**All specifications are preliminary which may be changed without any prior notice**

<b>1.</b>	<b>Summary</b> .....	<b>4</b>
<b>2.</b>	<b>Features</b> .....	<b>4</b>
<b>3.</b>	<b>Applicable Standard</b> .....	<b>5</b>
<b>4.</b>	<b>Block Diagram</b> .....	<b>5</b>
<b>5.</b>	<b>Electrical Characteristics</b> .....	<b>6</b>
5-1.	General Features .....	6
5-2.	Absolute Maximum Rating .....	7
5-3.	Recommended Operating Condition.....	7
5-4.	General radio characteristics .....	7
5-5.	Transmitter Specifications .....	7
5-6.	Receiver sensitivity.....	7
5-7.	Current Consumption .....	8
5-7-1.	Current consumption of RF part .....	8
5-7-2.	Average current consumption of Sensor (reference value).....	8
5-8.	Sensor specification .....	9
5-8-1.	Temperature sensor .....	9
5-8-2.	Humidity sensor .....	9
5-8-3.	Barometric Pressure .....	9
5-8-4.	Illuminance sensor .....	9
5-8-5.	Microphone.....	10
5-8-6.	3-axis Acceleration sensor .....	10
<b>6.</b>	<b>Interface specifications</b> .....	<b>11</b>
6-1.	Hardware Interface.....	11
<b>7.</b>	<b>Function Specification</b> .....	<b>12</b>
7-1.	Operation Mode.....	12
7-1-1.	Mode 1 (Normal mode).....	12
7-1-2.	Mode 3 (Recovery mode) .....	13
7-1-3.	Function of Push button and LED .....	13
<b>8.</b>	<b>Firmware</b> .....	<b>14</b>
8-1.	Firmware version .....	14
8-2.	Initial setting.....	15
<b>9.</b>	<b>Mechanical Characteristics</b> .....	<b>16</b>
9-1.	Appearance and Dimensions .....	16
9-2.	Graphic and QR code label.....	17
9-3.	Label specification .....	18

<b>10. Storage Conditions</b>	<b>18</b>
<b>11. Warranty period</b>	<b>18</b>
<b>12. Installation</b>	<b>19</b>
12-1. Removal of the bracket and battery cap	19
12-2. Power supply	20
12-2-1. Case.1: Battery powered.	20
12-2-2. Case.2: USB-powered.	22
12-2-3. USB cable	23
<b>13. Packing Specification in shipment</b>	<b>24</b>
13-1. Label	24
13-2. Shipment Packing	25
13-2-1. Shipping package	25
<b>14. Caution</b>	<b>26</b>
14-1. Firmware	26
14-2. Lithium Battery	26
<b>15. Compliance Statement</b>	<b>27</b>
<b>16. Version History</b>	<b>29</b>

## 1. Summary

This datasheet applies to the Wirepas Mesh 2.4 GHz based Mesh Sensor Unit FWM8BLZ08Y.

## 2. Features

This product is an antenna integrated Mesh Sensor Unit which incorporates Wirepas Mesh 2.4 GHz. It is possible to communicate in ISM (Industrial Scientific Medical) band.

Since Wirepas Mesh 2.4 GHz is a wireless mesh network technology that enables wireless IoT networking at massive scale, this product is suitable for building sensor network with integrated temperature, humidity, pressure, illuminance, ambient sound level sensor.

The followings are the key features.

- Wirepas Mesh 2.4 GHz enabled
- Dimension : 76.5mm x 74.2mm x 29.0mm
- Weight : 75 g (without AA batteries)
- Operating Temperature : -20 to +60 °C
- Operating Humidity : +20 to +80 %RH (Noncondensing)
- Integrated sensors : Temperature, humidity, pressure, accelerometer, illuminance, microphone (Sound level)
- Power Supply : Four AA batteries or +5V via USB type-C connector
- Water resistant and dustproof : IP65 (When battery operated)

Functions :

- Transmission of temperature, humidity, pressure, ambient light, sound level on mesh network.
- LED indicator (RED)
- Configurable by App config message or Remote API.
- Battery voltage level monitoring

### 3. Applicable Standard

- Wirepas Mesh 2.4 GHz v5
- FCC, ISED certification  
FWM8BLZ08Y contains the certificated module (FWM7BLZ20B).  
FCC ID of the certificated module: SQK-7BLZ20  
ISED ID of the certificated module: 337L-7BLZ20
- CE, UKCA Marking
- ARIB STD-T66  
Radio Act (Japan) Certification No. 007-AG0232
- (Certificated by the combination of embedded module.) RCM, R-NZ certification
- RCM, R-NZ certification
- RoHS Compliant

### 4. Block Diagram

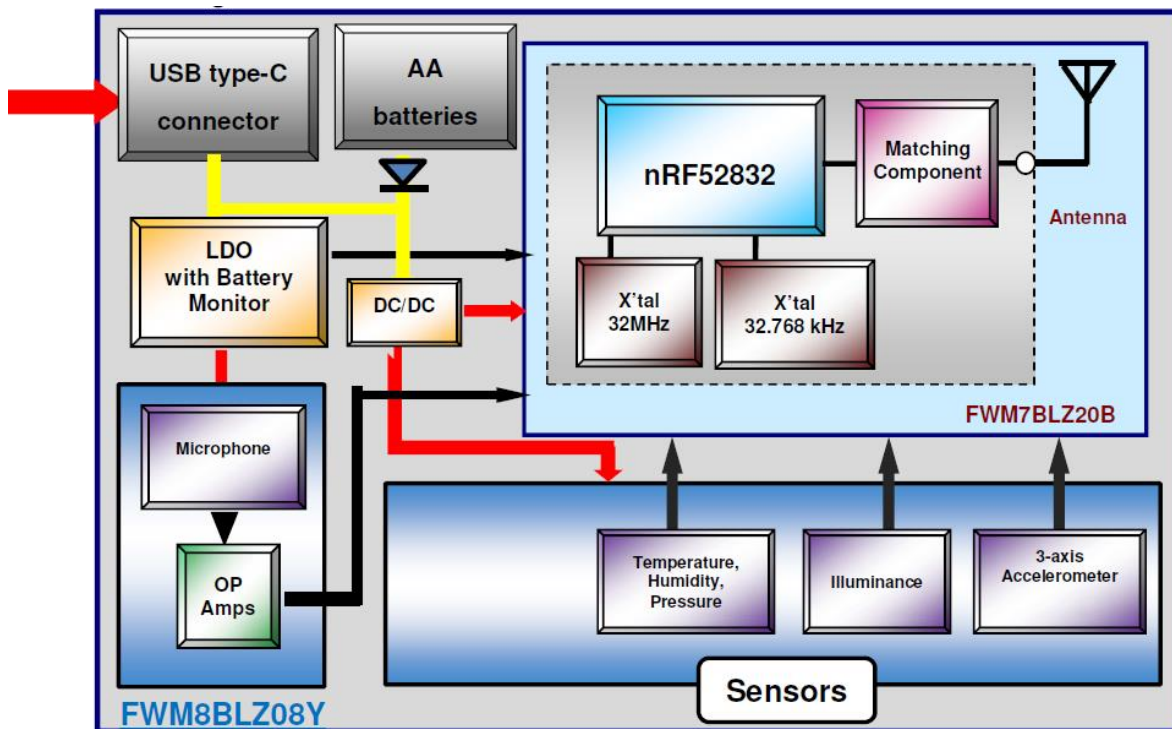

Figure 4-1: Block Diagram

## 5. Electrical Characteristics

### 5-1. General Features

Wirepas Mesh 2.4 GHz enabled

Carrier frequency : 2400 MHz to 2483.5 MHz

Modulation : GFSK

Data rate : 1 Mbps

Modulation index : 0.5

Channel : 40 channels

Channel spacing : 2 MHz

Output power : +4 dBm max

5-2. **Absolute Maximum Rating**

Items	Symbol	Min	Max	Unit
Supply Voltage (VDD)	VDD	-0.3	5.5	V
Supply Voltage (GND)	GND	-	0	V
Storage Temperature	Tstg	-20	+60	°C
Acceleration (Any axis)			20,000 g for 0.2msec	

5-3. **Recommended Operating Condition**

Items	Symbol	Min	Typ.	Max	Unit
Operating Voltage (USB)	VDD	4.5	5.0	5.5	V
Operating Voltage (Battery)	VDD	2.2	3.0	3.6	V
Operating Temperature	Ta	-20	25	+60	°C
Operating Humidity*	Hopr	20	-	80	%RH

\*No dew condensation

5-4. **General radio characteristics**

Ta=25±2°C

Items	Condition	Min	Typ.	Max	Unit
Operating frequencies	2MHz channel spacing	2400	-	2483.5	MHz
PLL programming resolution			1		MHz
Frequency deviation			±250		kHz

5-5. **Transmitter Specifications**

Ta=-20°C to 60°C

Items	Condition	Min	Typ.	Max	Unit
Output power		-20		+4	dBm
Step size of RF power control			4		dB
RF power control range			+24		dB

5-6. **Receiver sensitivity**

Ta=-20°C to 60°C

Items	Condition	Min	Typ.	Max	Unit
Maximum received signal strength	< 30.8% PER		0		dBm
Receiver sensitivity	Dirty transmitter < 30.8% PER		-94		dBm

Receiver specifications

Ta=25±2°C

Items	Condition	Min	Typ.	Max	Unit
RX selectivity (C/I performance)	Co-channel interference		6		dB
	Adjacent (-1 MHz) interference		-2		dB
	Adjacent (+1 MHz) interference		-9		dB
	Adjacent (-2 MHz) interference		-22		dB
	Adjacent (+2 MHz) interference		-46		dB
	Adjacent (>= 3 MHz) interference		-50		dB
	Image frequency interference		-22		dB
	Adjacent (1 MHz) interference to in-band image frequency		-35		dB
RX intermodulation	IMD performance (3 MHz, 4 MHz, and 5 MHz offset)		-30		dBm

5-7. Current Consumption

5-7-1. Current consumption of RF part

Vin=3.0V ,Ta=25±2°C

Description	Symbol	Typ.	Max.	Unit
TX current @ P <sub>OUT</sub> = +4 dBm	I <sub>TX,+4dBm</sub>	10.9		mA
TX current @ P <sub>OUT</sub> = 0 dBm	I <sub>TX,0dBm</sub>	8.0		mA
TX current @ P <sub>OUT</sub> = -4 dBm	I <sub>TX,-4dBm</sub>	7.3		mA
TX current @ P <sub>OUT</sub> = -8 dBm	I <sub>TX,-8dBm</sub>	6.6		mA
TX current @ P <sub>OUT</sub> = -12 dBm	I <sub>TX,-12dBm</sub>	6.3		mA
TX current @ P <sub>OUT</sub> = -16 dBm	I <sub>TX,-16dBm</sub>	6.1		mA
RX current	I <sub>RX</sub>	11.2		mA
Deep Sleep current	I <sub>SLEEP</sub>	5.5		uA

5-7-2. Average current consumption of Sensor (reference value)

Ta=25±2°C

Description	Symbol	Typ.	Max.	Unit
Temperature, Humidity, Barometric Pressure		6		uA
Illuminance		3		uA
Sound level		8		uA
3-axis Acceleration		2		uA

Note: Measurement interval: 10sec



## 5-8. Sensor specification

This product is integrated with

- Environmental sensor (Temperature, Humidity, Barometric pressure)
- Illuminance sensor
- Microphone (Sound level)
- 3-axis acceleration sensor

The specifications of each sensor are shown in the next section. However, the characteristics will change depending on the usage and environment, so please refer to them as reference values. FCL Components does not guarantee the characteristics.

### 5-8-1. Temperature sensor

Items	Symbol	Min	Typ.	Max	Unit
Full-Scale Range		-40		+85	°C
Absolute accuracy temperature	$A_{T,25}$		±0.5		°C
	$A_T$ , 0 to 65°C		±1.0		°C
Output resolution	$R_T$		0.01		°C

### 5-8-2. Humidity sensor

Items	Symbol	Min	Typ.	Max	Unit
Full-Scale Range		0		100	%RH
Absolute accuracy tolerance	$A_H$ 25°C, 20 to 80%RH		±3.0		%RH
Hysteresis <sup>1</sup>	$H_H$		±1.0		%RH
Output resolution	$R_T$		0.01		%RH

### 5-8-3. Barometric Pressure

Items	Symbol	Min	Typ.	Max	Unit
Full-Scale Range		300		1,100	hPa
Absolute accuracy tolerance	$A_{P,full}$ 0 to 65°C, 300 to 1000hPA		±1.0		hPa
Output resolution	$R_T$		0.01		hPa

### 5-8-4. Illuminance sensor

Items	Symbol	Min	Typ.	Max	Unit
Full-Scale Range		0		10,000	Lx
Output resolution			1		Lx

5-8-5. **Microphone (Sound level)**

Items	Symbol	Min	Typ.	Max	Unit
Full-Scale Range		0		90	dB SPL
Output resolution	R <sub>T</sub>		1		dB SPL

Note : Microphone characteristics are affected by installing condition and surrounding environment (indoor, outdoor, placement of shields etc.).

Therefore, it is recommended to check the characteristics in your environment before use.

5-8-6. **3-axis Acceleration sensor**

Items	Symbol	Min	Typ.	Max	Unit
<b>ACCELEROMETER SENSITIVITY</b>					
Full-Scale Range		0		±16	G
Output resolution			0.001		G

The axial direction is shown below.

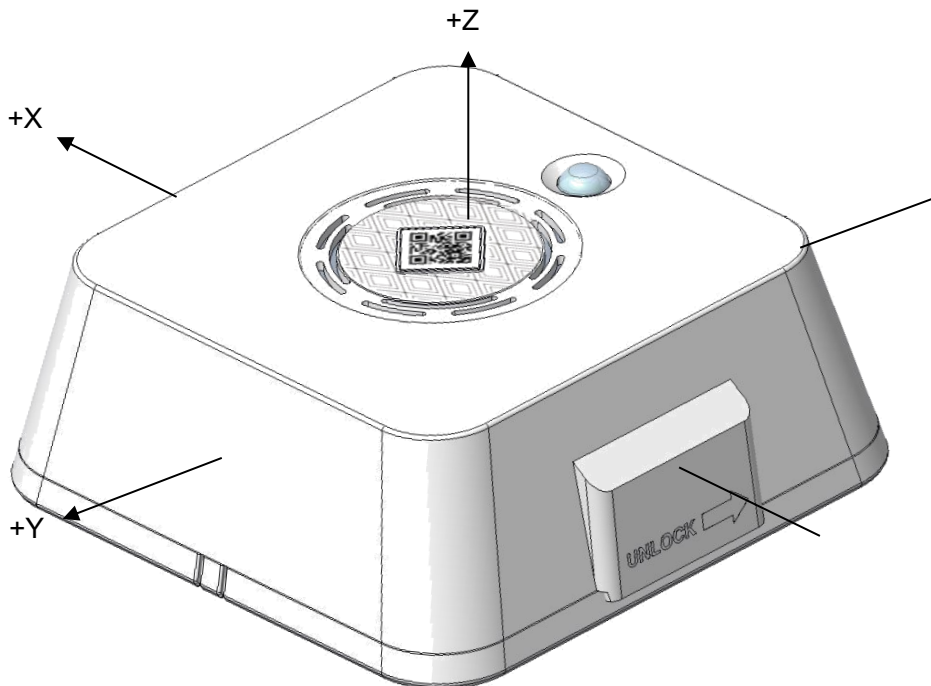

6. Interface specifications

6-1. Hardware Interface

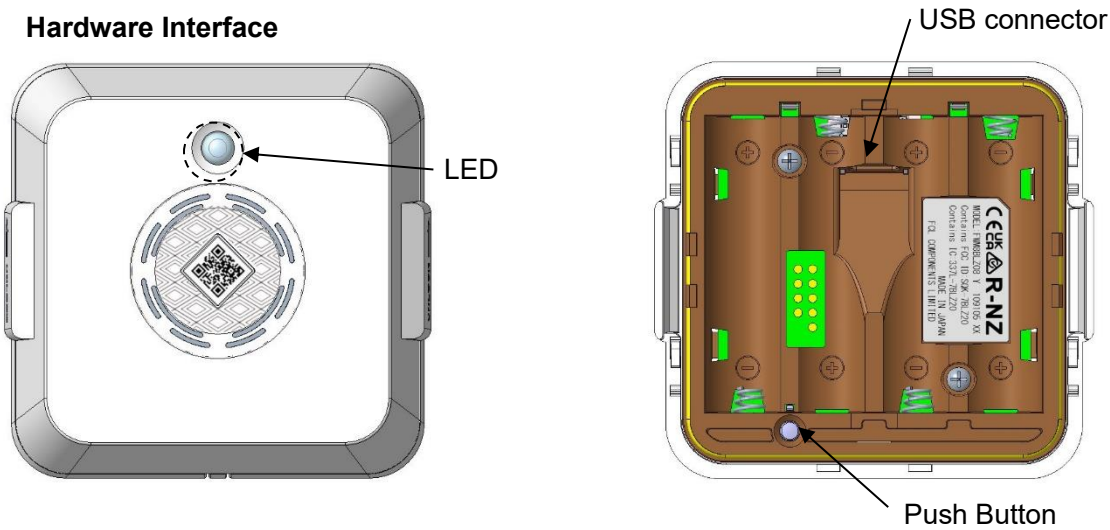

Figure 6-1: Hardware Interface

## 7. Function Specification

### 7-1. Operation Mode

This product has two types of operation modes shown in the table below, and the modes can be switched by operating the push button at startup.

Operation Mode	Description
Mode 1 (Normal mode)	This mode is intended for use in normal operation.
Mode 3 (Recovery Mode)	Deletes all settings and restores the default firmware.

Various operation settings of this product can be changed.

Settings can be changed using the Wirepas Terminal or Wirepas Network Tool.

(Settings can also be changed using the AppConfig function or Remote API.)

#### 7-1-1. Mode 1 (Normal mode)

Operating Instructions	Push Button	LED
Turn on the unit. *Please don't touch the push button during this process.	OFF	OFF
		Blinking (2 seconds)
		OFF

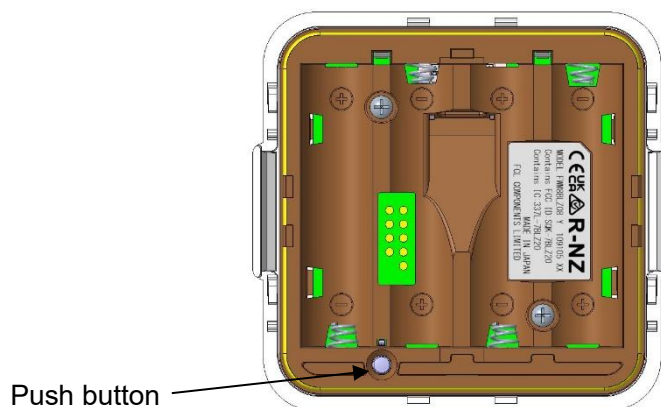

Figure 7-1: Mode 1

#### Behavior of Mode 1

After the unit is turned on, the LED indicator blinks for 2 seconds and then goes off. This LED blinking behavior can't be changed.

\* Refer to "Wirepas Mesh Sensor Unit Firmware Specification " for details.

7-1-2. **Mode 3 (Recovery mode)**

Operating Instructions	Push Button	LED
Turn on the unit with the push button pressed. After 2 seconds, the LED turns on.	ON	OFF
		OFF (2 seconds)
ON		
ON (15 seconds)		
Keep pressing the push button after the LED turns on for minimum 15 seconds. Release the push button within 5 seconds after the LED starts to flash. All the settings are restored to default settings and it reboots automatically.	OFF	Blinking (within 5 seconds)

If the push button is not released within 5seconds after the LED starts blinking, the unit will boot in Mode 1.

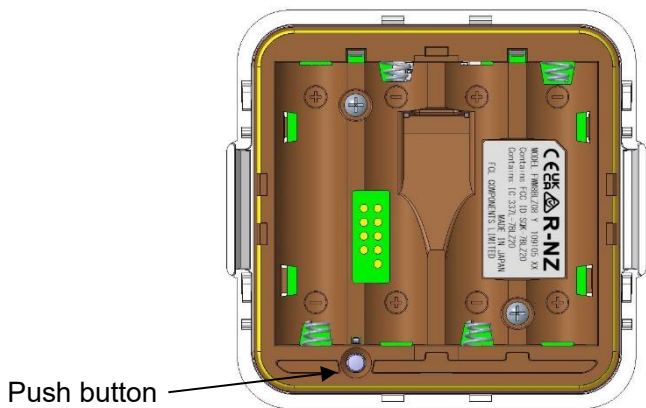

Figure 7-2: Mode 3

Behavior of Mode 3

The recovery mode is a function that aims to forcibly restore it to the initial settings when it is out of control due to a reason such as "Inappropriate settings are done to the product". This deletes all the settings and restores the firmware to initial settings. It reboots automatically after the recovery.

7-1-3. **Function of Push button and LED**

The push button is used to switch the operation mode (Mode 1, Mode 3: recovery mode) at startup.

The LED indicator shows the status when switching the operation mode.

## 8. Firmware

### 8-1. Firmware version

Revision *	Firmware version (Base version of Wirepas firmware is given in parenthesis).	App_version	App_specific_area_id
AA	wp_v1.00A_v5_** (05.01.00.61)	1.0.0.0	0xFC1082
BB	wp_v1.01A_v5_** (05.01.00.61)	1.01.0.0	0xFC1082
CC	wp_v2.00A_v5_** (05.03.00.89)	2.0.0.0	0xFC1082

\* Please refer to 9-3 Label specification.

There is no different behavior between the AA version and BB version of FWM8BLZ08Y.

## 8-2. Initial setting

Initial setting is as follows.

Parameter	Value
Node Address	Random number (4 byte)
Network Address	7986085 (0x79DBA5)
Network Channel	10
ENCRPTION_KEY_EN	0 (disable)
ENCRPTION_KEY_VALUE	-
AUTHENTICATION_KEY_EN	0 (disable)
AUTHENTICATION_KEY_VALUE	-
EP_BASE_NUM	0x06
NODE_ROLE	0x41 (Autorole Low Energy Router)
POS_OPERATION_MODE	-
POS_DEVICE_CLASS	F9
POS_MAX_SLEEP_TIME	-
POS_MAX_RUN_TIME	-
POS_MEASUREMENT_RATE	-
POS_ACCEL_THRESHOLD	-
POS_BATT	-
DATA_QOS	0 (Normal)
COMMAND_QOS	0 (Normal)
ADV_EN	0 (disable)
ADV_DATA_SEL	1 (fixed data)
FIXED_ADV_DATA_SEL	0 (Device name)
ADV_INT	0x0a (1sec)
SEN_MSR_INT	0x06 (60sec)
SEN_CONFIG	0x0F (enable all sensors)
SEN_SERVICE_ID	0x01
SEN_PROJECT_ID	0x01
SEN_COMPANY_ID	0x0D28
SEN_TXT_OUT_EN	0x01
SEN_TXT_FORMAT_SEL	0x00
SEN_BINARY_FORMAT_SEL	0x00
ALARM_EN	-
SEN_CO2_IND_THRE_GREEN	0x14
SEN_CO2_IND_THRE_RED	0x28
SEN_CO2_IND_INT	0x05
custom bootloader keys auth	69 63 87 5F 9C A5 33 64 37 20 2E 6E 1C B6 31 63
encrypt	3E 77 0C 4D 13 5B 02 CA 23 A7 22 AE 59 5F 53 3C

If you turn on the product in Mode 3 as described in 7-1-2, all the settings are reset to the initial value of the firmware settings as shipped from the factory.

Unless otherwise specified, other settings will not be overwritten.

9. Mechanical Characteristics

9-1. Appearance and Dimensions

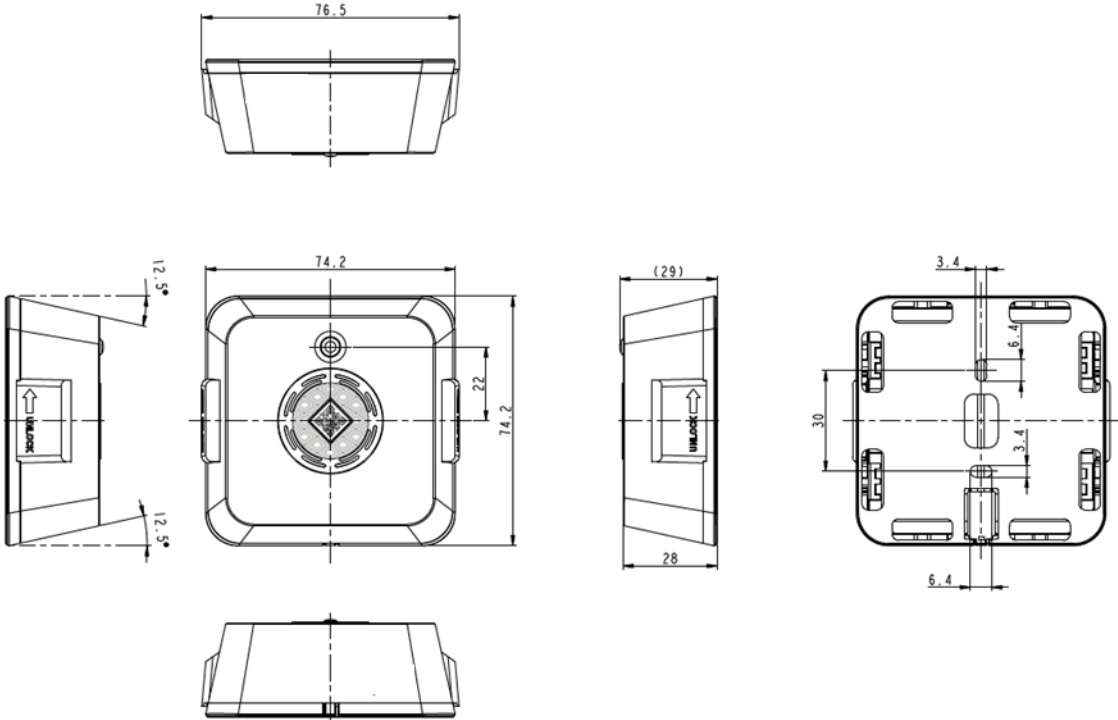

Unit [mm]



## 9-2. Graphic and QR code label



Graphic label

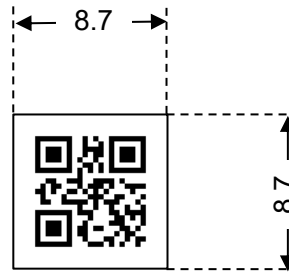

QR code label

### QR code label specification

Dimension: Label size: 8.7 \* 8.7 mm

QR code size: 7.0 \* 7.0 mm (Typ)

Information:

(1) Node address

### Notes

- Please keep the QR code label clean to prevent misreading QR code.
- When wiping off dirt, wipe gently with a soft cloth. Please do not wipe forcefully or using chemical cleaning such as alcohol to prevent damage the QR code label.

9-3. Label specification

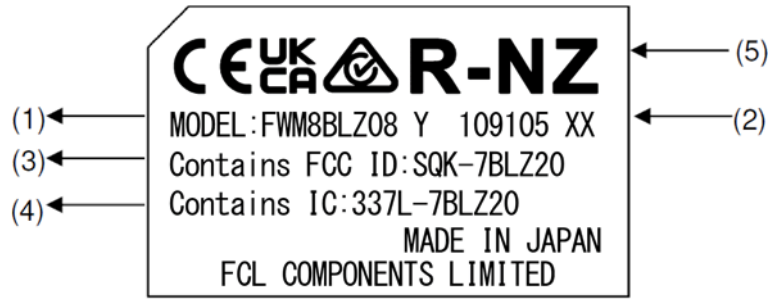

(1) FCL Identification Number + Identification symbol: FWM8BLZ08 + Y

(2) Version number, FCL Identification Number

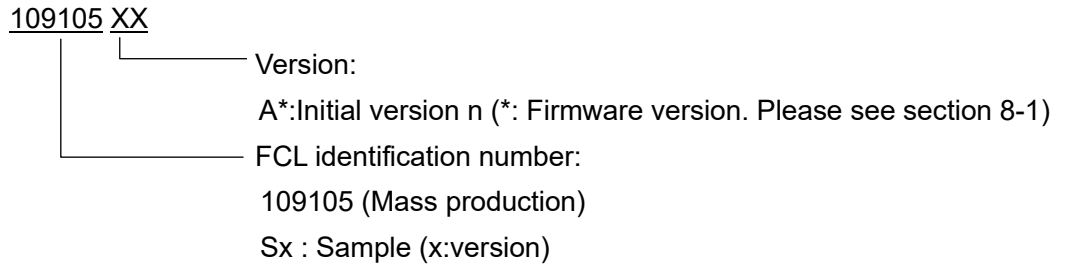

(3) FCC ID of contained module.

(4) ISED ID of contained module.

(5) Certification logo (CE, UKCA, RCM, R-NZ)

10. Storage Conditions

- Do not store this product in the environments exposed to shock or vibration. It may result in damage, malfunction, or deterioration of quality.
- Do not throw or drop cartons containing this product during transportation. It may result in damage, malfunction, or deterioration of quality.

11. Warranty period

The warranty period for this product is 18 months after the product is shipped from us.

Note 1: We can not provide any warranty for the operation of this product in all vibrating condition.

Please check in your own environment before use.

## 12. Installation

### 12-1. Removal of the bracket and battery cap

1. Slide the bracket in the direction of red arrow, and claws will be unlocked.
2. Lift the bracket and remove it.
3. Remove the battery cap

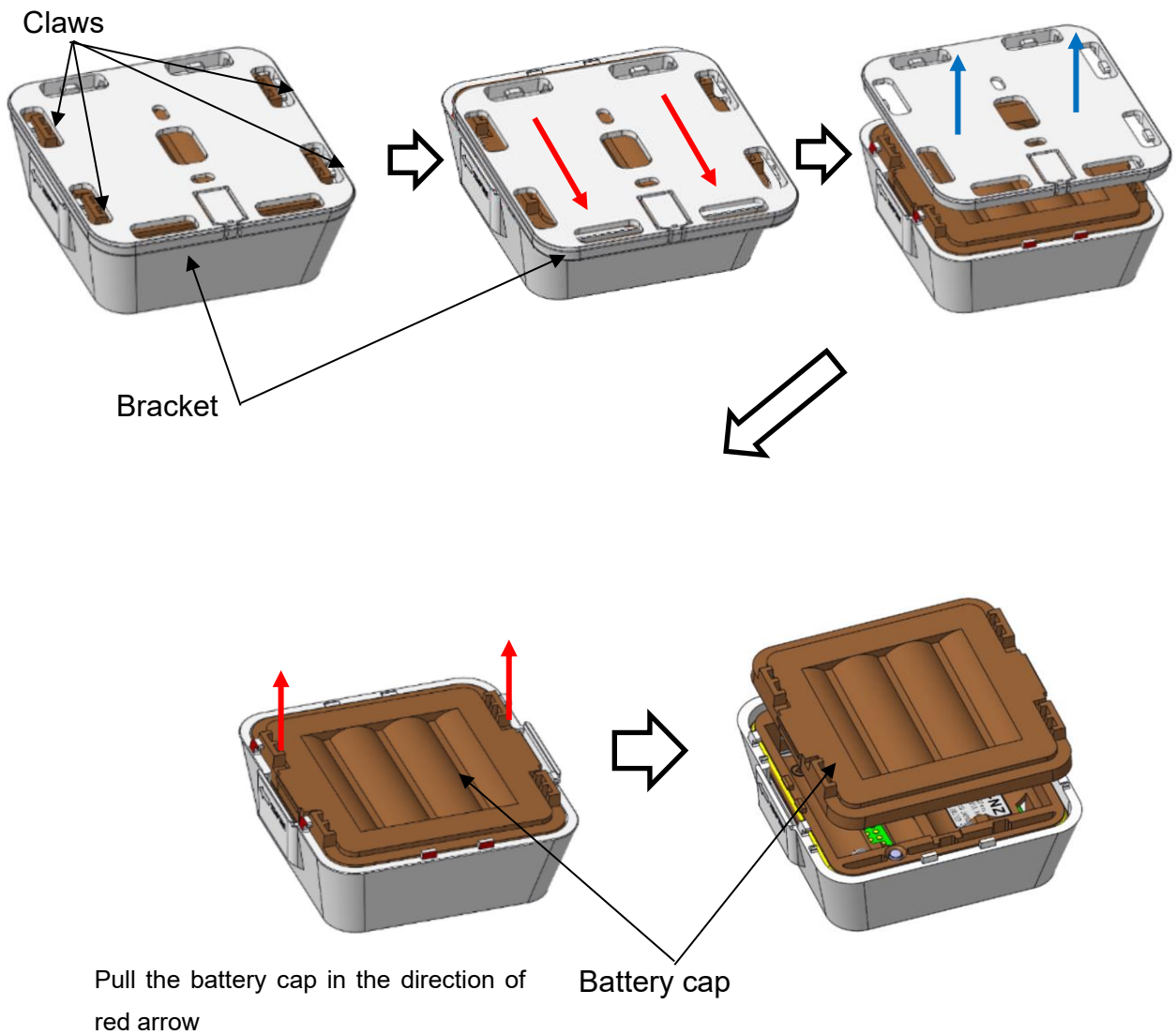

## 12-2. Power supply

### 12-2-1. Case.1: Battery powered.

1. Insert 4 AA batteries with its positive (+) and negative (-) terminals properly aligned with the corresponding symbols in the battery box.

Caution: Do not mix old batteries and new batteries.

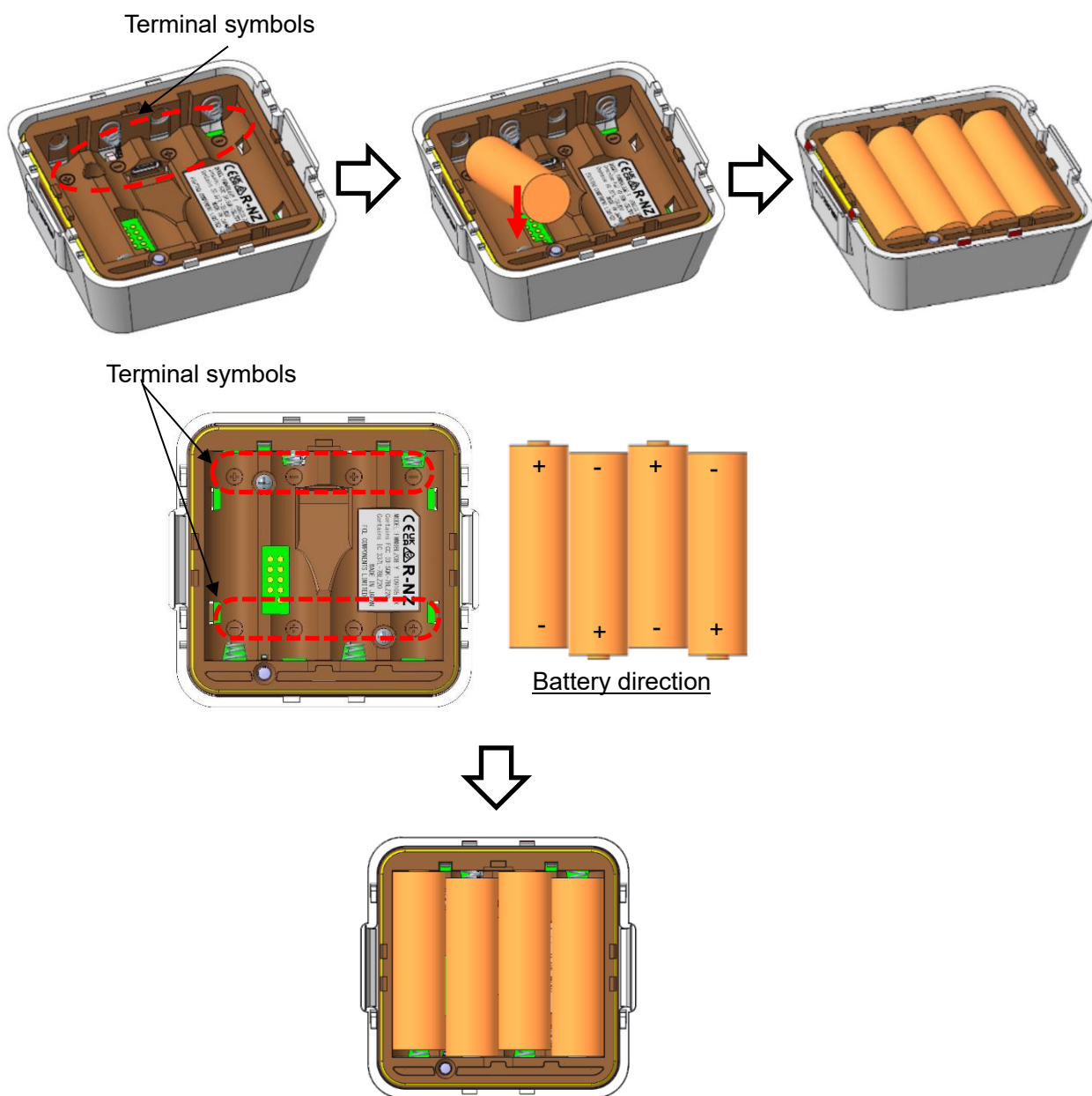

Close the battery cap and attach the bracket

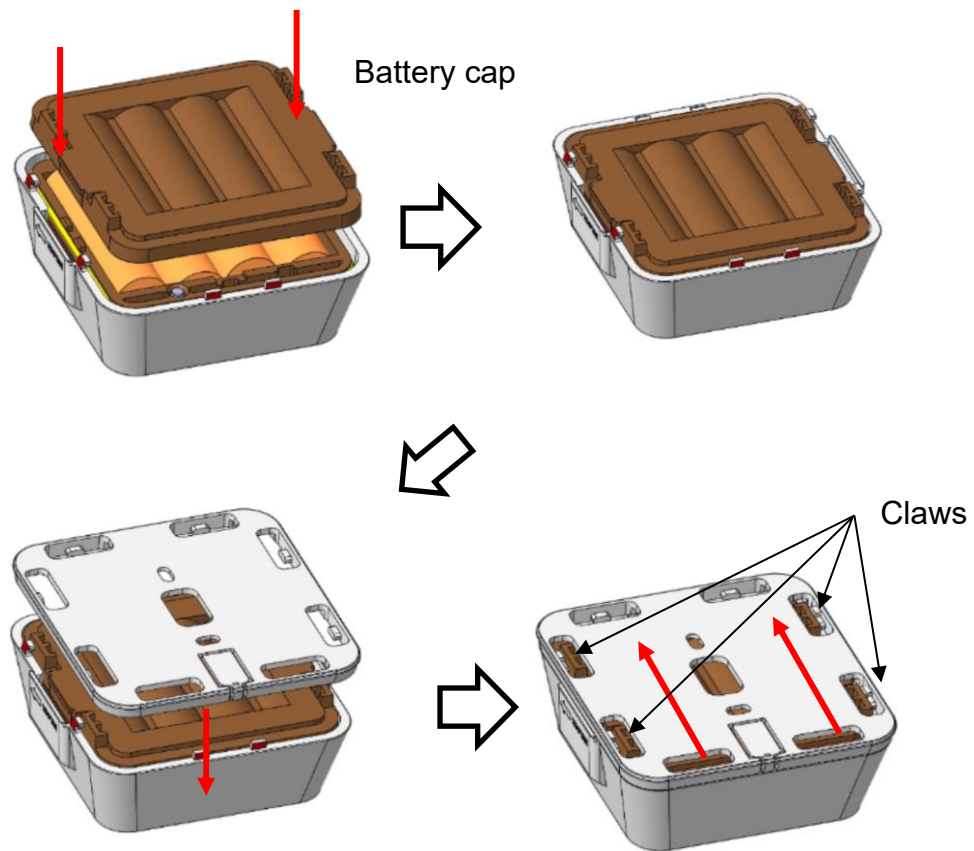

Caution : Please confirm the claws are locked correctly.

Note:

- Please press the battery cap all the way in to keep the water resistant and dustproof performance.

12-2-2. Case.2: USB-powered.

1. Insert USB type-C cables to the USB connector.
2. Attach the bracket (Do not apply the battery cap).

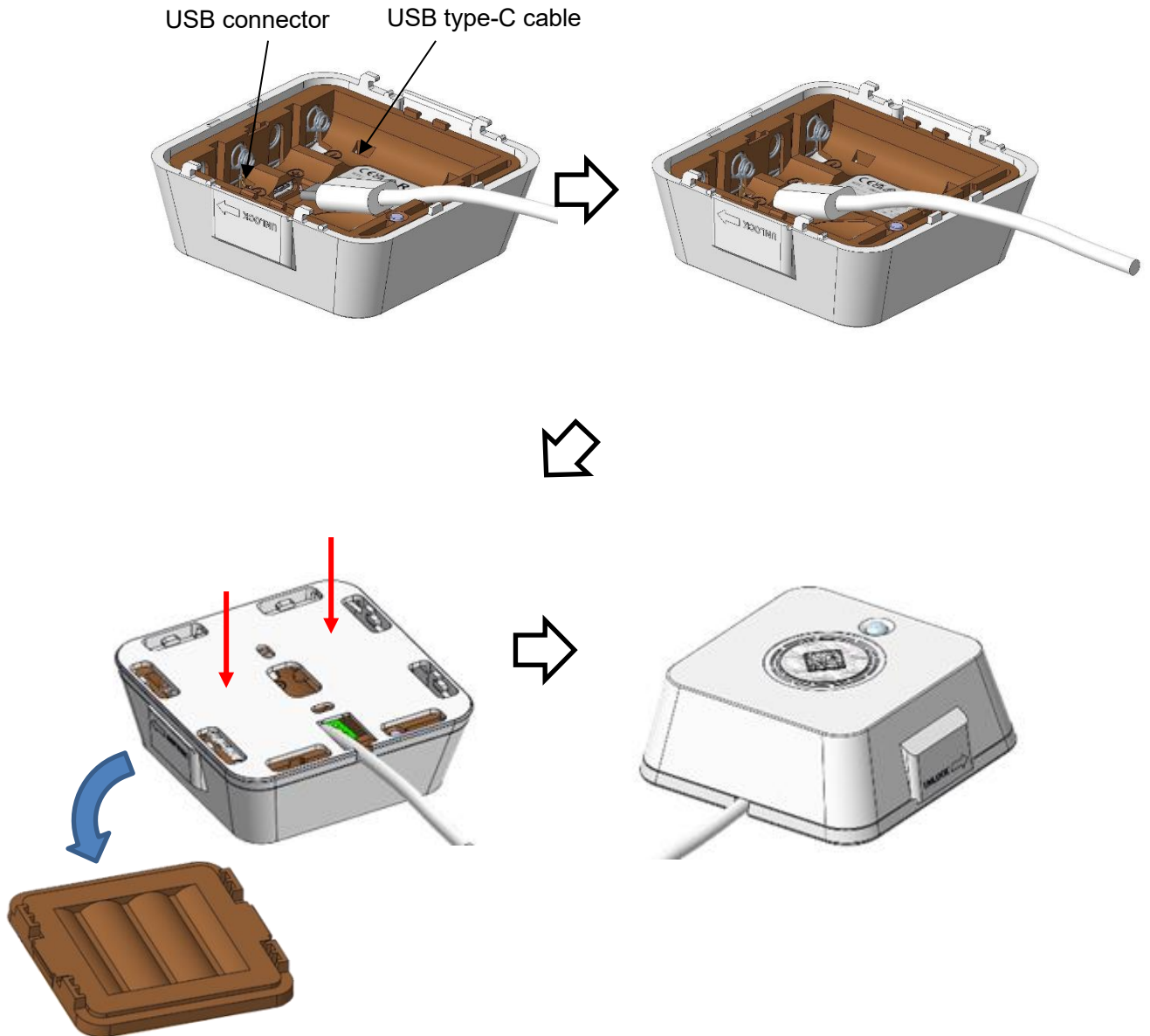

Do not attach the battery cap when USB cable is used.

### 12-2-3. USB cable

Recommended dimension of USB cable is as follows.

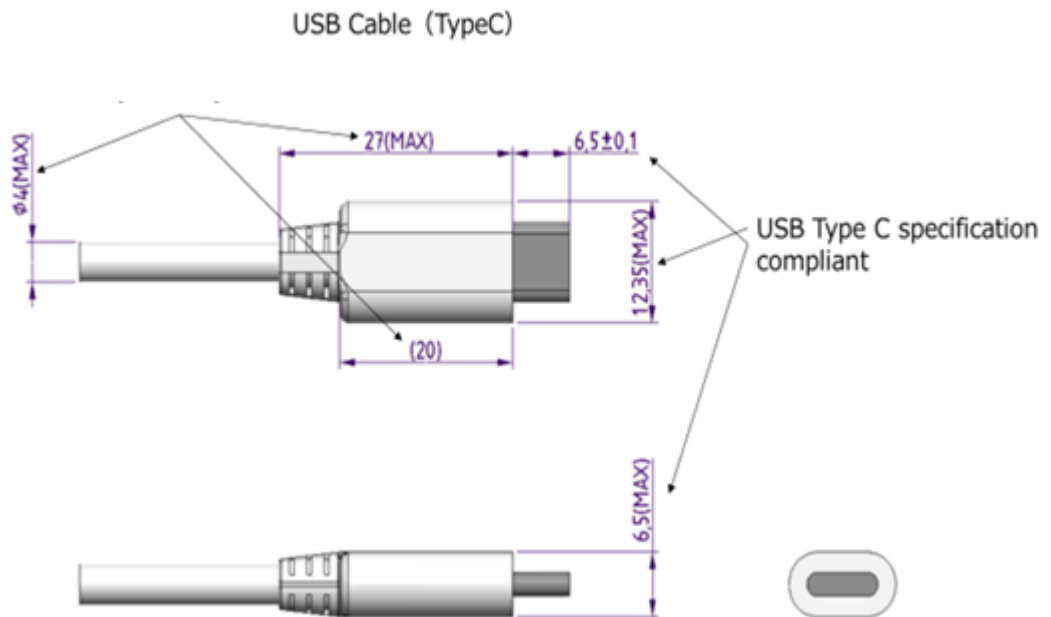

#### Notes

- The water resistant and dustproof performance are not applied if USB cable is used.
- Please do not connect the USB cable when the unit and/or USB cable is wet.

### 13. Packing Specification in shipment

#### 13-1. Label

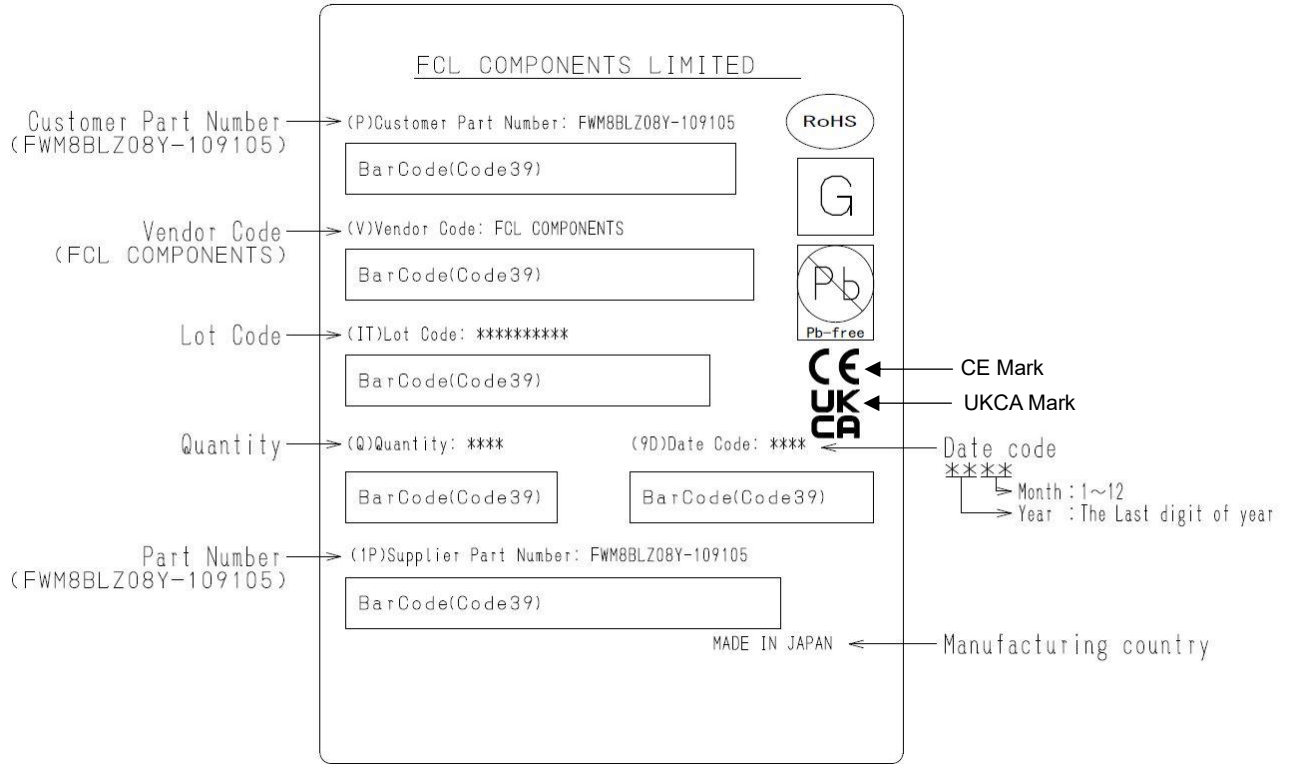



## 13-2. Shipment Packing

### 13-2-1. Shipping package

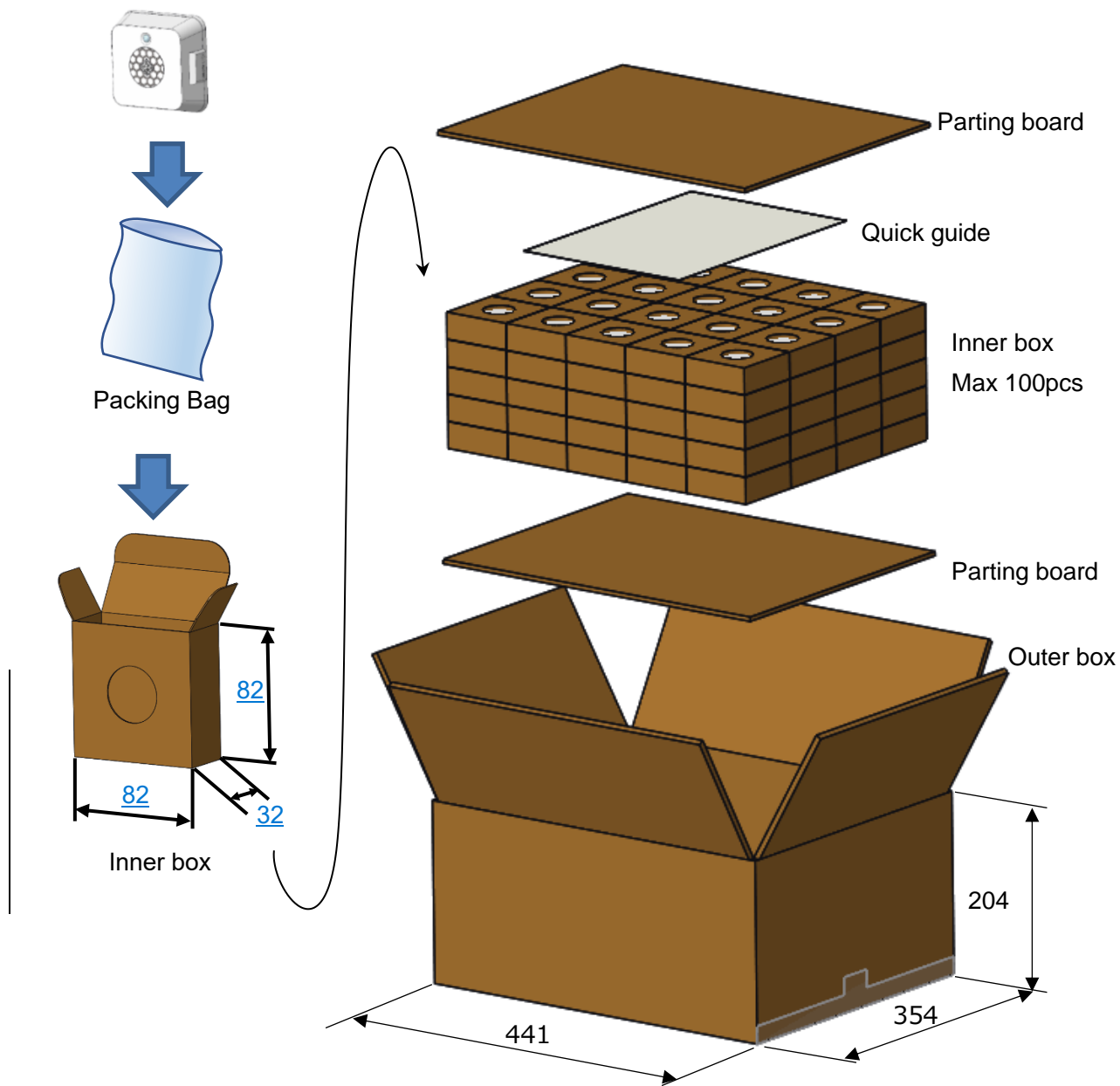

Unit: mm

#### Note

- The purpose of the outer box and inner box is used to absorb the impact on the product during transportation. The boxes may be damaged or deformed due to the handling during the transportation.

## **14. Caution**

### **14-1. Firmware**

- FCL Components Limited (“FCL”) may update the firmware without prior notice.
- FCL does not provide the firmware update to the products already delivered to customer. If you wish to continuously use the prior version of firmware, please contact your nearest FCL Components’s sales office.

### **14-2. Lithium Battery**

If any type of Lithium battery is used, be aware of following points.

- RISK OF EXPLOSION IF BATTERY IS REPLACED BY AN INCORRECT TYPE.
- RISK OF EXPLOSION OR THE LEAKING FLAMMABLE LIQUID OR GAS IF FOLLOWING IS APPLIED.
  - ✧ Replaced by incorrect battery type.
  - ✧ Mixture of new and used batteries.
  - ✧ Dispose to a heated furnace or incinerator.
  - ✧ Leaving at excessively high and low temperature condition.
  - ✧ Leaving at excessive low pressure.
  - ✧ Mechanical stress such as crushing, puncturing or cutting.
- Disposal of used batteries must follow the instruction or rules of the regional authority

## 15. Compliance Statement

### Note to users in the United States of America

#### Caution:

Changes or modifications not expressly approved by the party responsible for compliance could void the user's authority to operate the equipment.

#### Declaration of Conformity

This device complies with part 15 of FCC Rules.

Operation is subject to the following two conditions:

1. This device may not cause harmful interference, and
2. This device must accept any interference received, including interference that may cause undesired operation.

### Note to users in the United States of America and Canada

#### Note to users

It is strictly forbidden to use antenna except designated.

This equipment must not be co-located or operated in conjunction with any other antenna or transmitter.

This equipment complies with FCC/IC radiation exposure limits set forth for an uncontrolled environment and meets the FCC radio frequency (RF) Exposure Guidelines and RSS-102 of the IC radio frequency (RF) Exposure rules. This equipment has very low levels of RF energy that is deemed to comply without testing of specific absorption rate (SAR).

#### Note to users in Canada

Cet équipement est conforme aux limites d'exposition aux rayonnements énoncées pour un environnement non contrôlé et respecte les règles d'exposition aux fréquences radioélectriques (RF) CNR-102 de l'IC. Cet équipement émet une énergie RF très faible qui est considérée conforme sans évaluation de l'exposition maximale autorisée.

#### Note to users in Canada

This device complies with Industry Canada's license-exempt RSSs.

Operation is subject to the following two conditions:

- (1) This device may not cause interference; and
- (2) This device must accept any interference, including interference that may cause undesired operation of the device.

### **Remarque concernant les utilisateurs au Canada**

Le présent appareil est conforme aux CNR d'Industrie Canada applicables aux appareils radio exempts de licence. L'exploitation est autorisée aux deux conditions suivantes :

- (1) l'appareil ne doit pas produire de brouillage, et
- (2) l'utilisateur de l'appareil doit accepter tout brouillage radioélectrique subi, même si le brouillage est susceptible d'en compromettre le fonctionnement.

### **European Community Compliance Statement**

#### **Note:**

Hereby, FCL Components Limited, declares that this FWM8BLZ08 is in compliance with the essential requirements and other relevant provisions of Directive 2014/53/EU.

The full text of the declaration of conformity is available at the following internet address:

<https://www.fcl-components.com/en/products/wireless-modules/>



### **Note to users in the Great Britain**

#### **United Kingdom conformity Assessed Compliance Statement**

#### **Note:**

Hereby, FCL Components Limited, declares that this FWM8BLZ08 is in compliance with the relevant statutory requirements.

The full text of the declaration of conformity is available at the following internet address:

<https://www.fcl-components.com/en/products/wireless-modules/>



#### **Risk assessment:**

As part of the risk assessment on an on-going and periodic basis we will monitor the designated standards list published by the Office for Product Safety and Standard and also the Department for Business, Energy & Industrial Strategy relevant to the Statutory Instrument correct references to radio Equipment for new standards to ensure that the assessment methods are updated as new standards become available. We will also check the ETSI list of published standards for updates to EMC standards pending designation of suitable standards.

## 16. Version History

Version	Content change	Date
1	Initial release	July 1, 2021
1.1	<p>'9-3. Label specification' is changed.</p> <p>'12-2-3 USB cable' is added</p> <p>'13-2. Shipping package' is changed / added.</p> <p>'14-2. Caution (Lithium battery)' is added.</p>	Oct 27, 2021
1.2	<p>2. Features, 9-1 Dimensions are changed.</p> <p>3.Applicable standard: UKCA, RCM, R-NZ are added</p> <p>8. Firmware is revised.</p> <p>'15. Compliance statement' is added</p>	Jan 18, 2022
1.3	<p>13-1. CE / UKCA marking are added to the label.</p> <p>13-2-1. Quick guide is added.</p>	Mar 28, 2022
2	Change of Company name	Feb 1, 2024