

FCL Components Wireless modules

Mesh Unit (Wirepas Mesh 2.4 GHz based)

FWM8BLZ07P-109114 Datasheet

Ver. 2
Feb 1, 2024

The above Product is designed, developed and manufactured as contemplated for general use, including without limitation, general office use, personal use, household use, and ordinary industrial use, but is not designed, developed and manufactured as contemplated (1)for use accompanying fatal risks or dangers that, unless extremely high safety is secured, could lead directly to death, personal injury, severe physical damage or other loss (i.e., nuclear reaction control in nuclear facility, aircraft flight control, air traffic control, mass transport control, medical life support system, missile launch control in weapon system), or (2)for use requiring extremely high reliability (i.e., submersible repeater and artificial satellite), hereinafter referred to as "High Safety Required Use". You shall not use this Product without securing the sufficient safety or reliability required for the High Safety Required Use. If you wish to use this Product for High Safety Required Use, please consult with our sales representatives in charge before such use.

FCL Components Limited

**The content of this document may be changed without any prior notice,
so please make sure this document is the latest version.**

1.	Summary	4
2.	Features	4
3.	Applicable Standard	5
4.	Block Diagram	5
5.	Electrical Characteristics	6
5-1.	General Features	6
5-2.	Absolute Maximum Rating	7
5-3.	Recommended Operating Condition.....	7
5-4.	General radio characteristics	7
5-5.	Transmitter Specifications	7
5-6.	Receiver sensitivity.....	7
5-7.	Receiver specifications.....	8
5-8.	Current Consumption	8
5-8-1.	Current consumption of RF part	8
5-8-2.	Average current consumption of Sensor (reference value).....	8
5-9.	3-axis Acceleration sensor	9
6.	Interface specifications	10
6-1.	Software Interface	10
6-2.	Hardware Interface	10
7.	Function Specification	11
7-1.	Operation Mode.....	11
7-1-1.	Mode 1 (Normal mode).....	11
7-1-2.	Mode 3 (Recovery mode)	12
7-1-3.	Function of Push button and LED	12
8.	The Firmware initial default setting and factory default setting	13
9.	Mechanical Characteristics	14
9-1.	Appearance and Dimensions	14
9-2.	Stamping label specification.....	14
10.	Storage Conditions	15
11.	Warranty period	15
12.	Mounting / Replacement method of battery	16
12-1.	About using lithium battery 'CR2450'	16
12-2.	Removal of a battery cover lid.....	16
12-3.	Mounting of a battery	17

12-4.	Installation of a battery cover lid	17
12-5.	Replace battery	18
12-6.	Precautions for handling batteries	18
13.	Packing Specification in shipment	19
13-1.	Reel label	19
13-1-1.	Tray packing	20
13-1-2.	Shipping package	22
14.	Compliance Statement	23
15.	Caution about Firmware installed	25
16.	Version History	25

1. Summary

This datasheet applies to the Wirepas Mesh 2.4 GHz based Mesh Unit FWM8BLZ07P-109114.

2. Features

This product is an antenna integrated Mesh Unit which incorporates Wirepas Mesh 2.4 GHz. It is possible to communicate in 2.4 GHz ISM (Industrial Scientific Medical) band.

Since Wirepas Mesh is a wireless mesh network technology that enables wireless IoT networking at massive scale mainly used for asset tracking.

The followings are the key features.

- Wirepas Mesh 2.4 GHz enabled
- Dimension: 40.0mm x 31.0mm x 12.0mm
- Weight: 9.4g (without CR2450 coin-cell battery)
- Operating Temperature: -30 to +60 °C (without CR2450 coin-cell battery)
- Operating Humidity: +20 to +80 %RH (No dew condensation)
- Integrated sensors: 3-axis acceleration
- Power Supply: Coin-cell battery 3V (CR2450)

The functions are as follow:

- Positioning mode function.
- Each mode is switched by a button operation.
- Acceleration sensor wakes up the unit from sleep mode.
- Status display by LED indicator
- Configurable by App config message or Remote API.
- Battery voltage level monitoring

3. Applicable Standard

- Wirepas Mesh 2.4GHz, v5
- FCC, ISED certification
FCC ID: SQK-7BLZ20
ISED ID: 337L-7BLZ20
- CE Marking
- ARIB STD-T66
Radio Act (Japan) Certification No. 007-AG0232
(Certificated by the combination of embedded module.)
- RoHS Compliant

4. Block Diagram

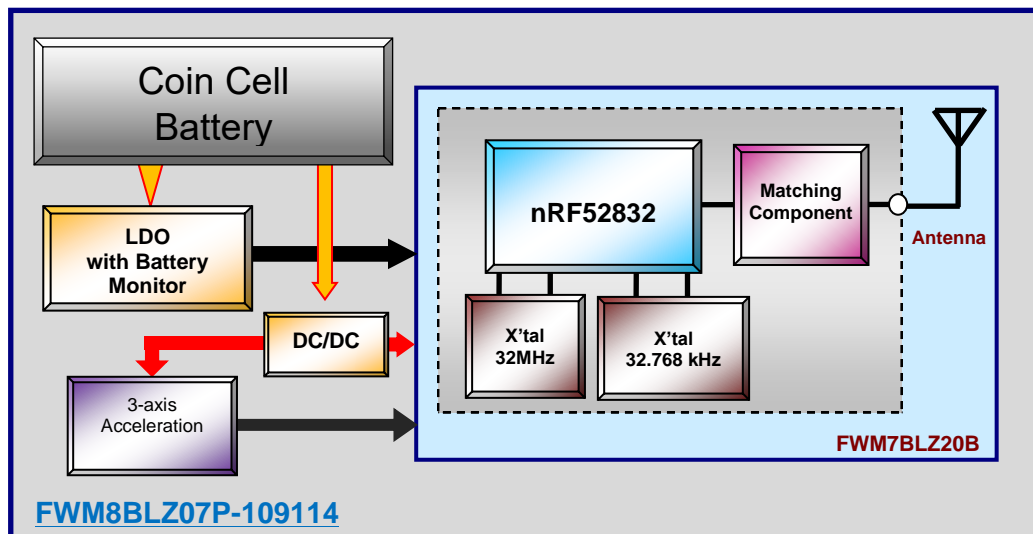

Figure 4-1: Block Diagram

5. Electrical Characteristics

5-1. General Features

Wirepas Mesh 2.4 GHz enabled

Carrier Frequency: 2400 MHz to 2483.5 MHz

Modulation: GFSK

Data Rate: 1 Mbps

Moduration Index: 0.5

Channel: 40 channels

Channel Spacing: 2 MHz

Output power: +4 dBm max

5-2. Absolute Maximum Rating

Items	Symbol	Min	Max	Unit
Supply Voltage (VDD)	VDD	-0.3	6.0	V
Supply Voltage (GND)	GND	-	0	V
Storage Temperature	Tstg	-30	+60	°C

5-3. Recommended Operating Condition

Items	Symbol	Min	Typ	Max	Unit
Operating Voltage	VDD	2.5	3.0	3.3	V
Operating Temperature	Ta	-30	25	+60	°C
Operating Humidity	Hopr	20	-	80	%RH

*No dew condensation

5-4. General radio characteristics

Ta=25±2°C

Items	Condition	Min	Typ	Max	Unit
Operating frequencies	2MHz channel spacing	2400	-	2483.5	MHz
PLL programming resolution			1		MHz
Frequency deviation			±250		kHz

5-5. Transmitter Specifications

Ta=-30°C to 60°C

Items	Condition	Min	Typ	Max	Unit
Output power		-20		+4	dBm
Step size of RF power control			4		dB
RF power control range			+24		dB

5-6. Receiver sensitivity

Ta=-30°C to 60°C

Items	Condition	Min	Typ	Max	Unit
Maximum received signal strength	< 30.8% BLE PER		0		dBm
Receiver sensitivity	Dirty transmitter < 30.8% BLE PER		-94		dBm

5-7. Receiver specifications

Ta=25±2°C

Items	Condition	Min	Typ	Max	Unit
RX selectivity (C/I performance)	Co-channel interference		6		dB
	Adjacent (-1 MHz) interference		-2		dB
	Adjacent (+1 MHz) interference		-9		dB
	Adjacent (-2 MHz) interference		-22		dB
	Adjacent (+2 MHz) interference		-46		dB
	Adjacent (>= 3 MHz) interference		-50		dB
	Image frequency interference		-22		dB
	Adjacent (1 MHz) interference to in-band image frequency		-35		dB
RX intermodulation	IMD performance (3 MHz, 4 MHz, and 5 MHz offset)		-30		dBm

5-8. Current Consumption

5-8-1. Current consumption of RF part

Ta=25±2°C

Description	Symbol	Typ.	Max.	Unit
TX current @ P _{OUT} = +4 dBm	I _{TX,+4dBm}	10.9	16.0	mA
TX current @ P _{OUT} = 0 dBm	I _{TX,0dBm}	8.0	12.0	mA
TX current @ P _{OUT} = -4 dBm	I _{TX,-4dBm}	7.3	11.0	mA
TX current @ P _{OUT} = -8 dBm	I _{TX,-8dBm}	6.6	10.0	mA
TX current @ P _{OUT} = -12 dBm	I _{TX,-12dBm}	6.3	9.5	mA
TX current @ P _{OUT} = -16 dBm	I _{TX,-16dBm}	6.1	9.0	mA
RX current	I _{RX}	11.2	16.3	mA
Deep Sleep current	I _{SLEEP}	5.5		uA

5-8-2. Average current consumption of Sensor (reference value)

Ta=25±2°C

Description	Symbol	Typ.	Max.	Unit
3-axis Acceleration		35		uA

5-9. **3-axis Acceleration sensor**

Items	Symbol	Min	Typ	Max	Unit
ACCELEROMETER SENSITIVITY					
Full-Scale Range		0		±16	G
Output resolution			0.001		G

The 3-axis acceleration sensor is only used to wake up the unit from sleep mode by shock detection. Therefore, the sensor will not output any data. For the details about accelerometer shock detection and the data calculation method for each sensor, please refer to the "Wirepas Mesh Sensor Unit Firmware Specification".

The axial direction

The axial direction is shown in the following image.

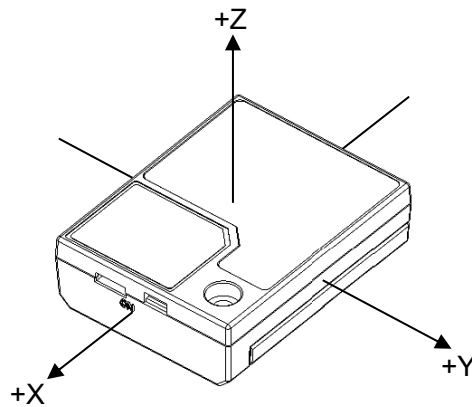

6. Interface specifications

6-1. Software Interface

Refer to the following documents.

- (1) Wirepas Mesh Sensor Unit Firmware Specification
- (2) Wirepas Mesh Dual-MCU API Reference Manual
- (3) Wirepas Mesh Diagnostics Reference Manual
- (4) Wirepas Mesh Remote API Reference Manual

6-2. Hardware Interface

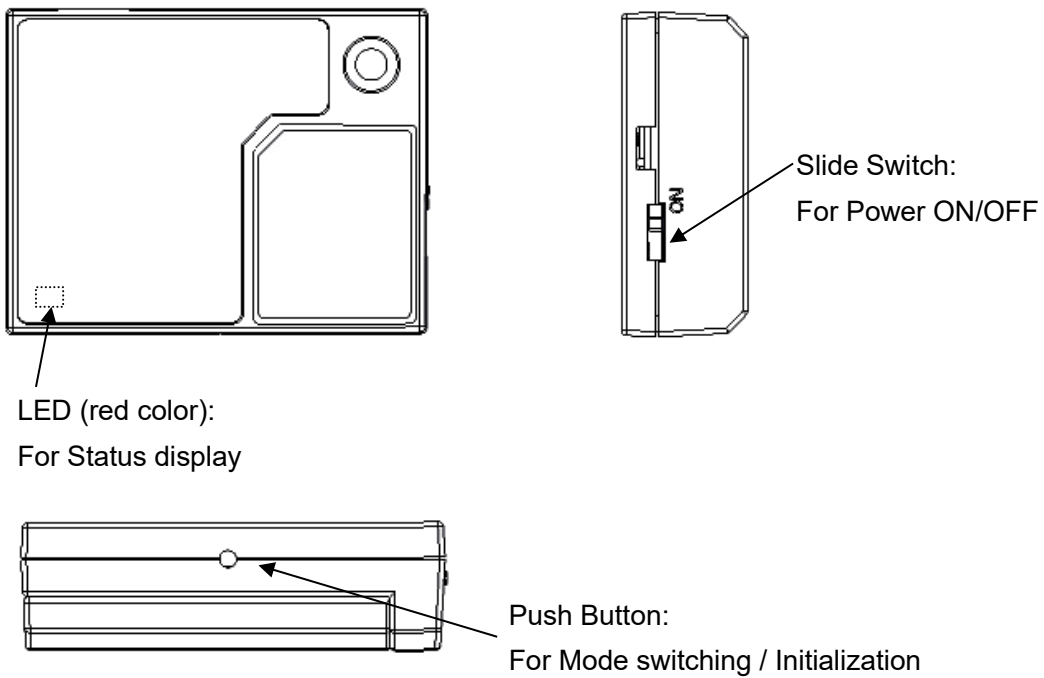

Figure 6-1: Hardware Interface

7. Function Specification

7-1. Operation Mode

This product has two types of operation modes as shown in the table below, and the modes can be switched by operating the slide switch and button at startup.

Operation Mode	Description
Mode 1	This mode is intended for use in normal operation.
Mode 3 (Recovery Mode)	Deletes all settings and restores the default firmware.

Various operation settings of this product can be changed.

Settings can be changed using the Wirepas Terminal or Wirepas Network Tool.

(Settings can also be changed using the AppConfig function or Remote API.)

7-1-1. Mode 1 (Normal mode)

Operating Instructions	Slide Switch	Push Button	LED
Turn on the slide switch. *Please don't touch the push button during this process.	OFF	OFF	OFF
	ON		Blinking (2 seconds)
			OFF

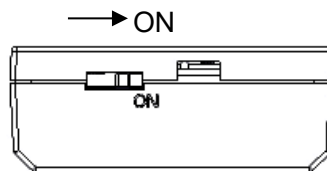

Figure 7-1: Mode 1

Behavior of Mode 1

After the slide switch is turned on, the LED indicator flashes for 2 seconds and then goes off. This LED blinking behavior can't be changed.

When the slide switch is turned on, the advertising function is activated and the advertisement data can be set by WRITE_ADV_NV command. Then, it advertises the data at the transmission interval set by the WRITE_ADV_INT_NV command.

* Refer to "Wirepas Mesh Sensor Unit Firmware Specification".

7-1-2. **Mode 3 (Recovery mode)**

Operating Instructions	Slide Switch	Push Button	LED
Turn on the slide switch with the push button pressed. After 2 seconds, the LED turns on.	OFF	ON	OFF
	ON		OFF (2 seconds)
Keep pressing the push button after the LED turns on. Release the push button within 5 seconds after the LED starts blinking. All the settings are restored to default settings and it reboots automatically.			ON
			ON (15 seconds)
		Blinking (within 5 seconds)	
		OFF	

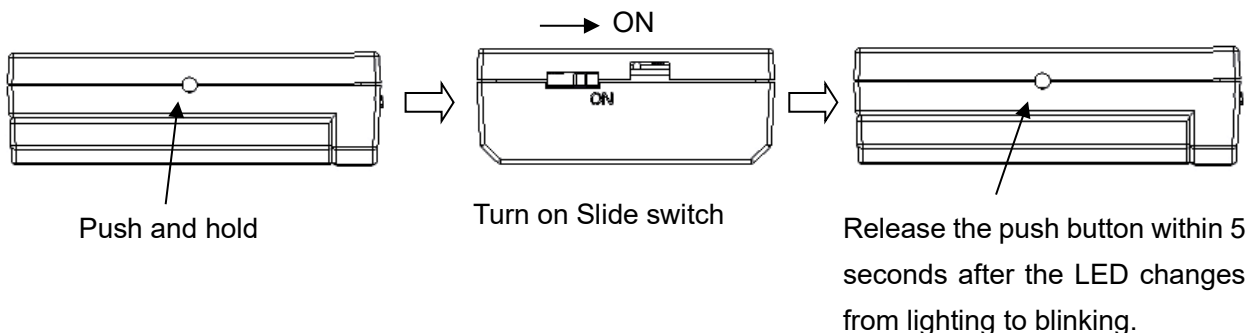

Figure 7-2: Mode 3

Behavior of Mode 3

The recovery mode is a function that aims to forcibly restore it to the default settings when it is out of control due to a reason such as "Inappropriate settings are done to the product". This deletes all the settings and restores the firmware to factory settings. It reboots automatically after the recovery.

7-1-3. **Function of Push button and LED**

The push button is used to switch the operation mode (Mode 1, Mode 3: recovery mode) at startup. The LED indicator shows the status when switching the operation mode.

8. The Firmware initial default setting and factory default setting

If you turn on the product in Mode 3 as described in 7-1-2, all the settings are reset to the default value of the firmware settings as shipped from the factory. Unless otherwise specified, other settings will not be overwritten.

Firmware version: wp_v3.00_v5_*(XX.XX.XX.XX)

"" Part assigns a number to each customer

"XX.XX.XX.XX"part: Wirepas base firmware version

Refer to " Wirepas Mesh Sensor Unit Firmware Specification".

The initial settings are subject to change due to firmware versions.

9. Mechanical Characteristics

9-1. Appearance and Dimensions

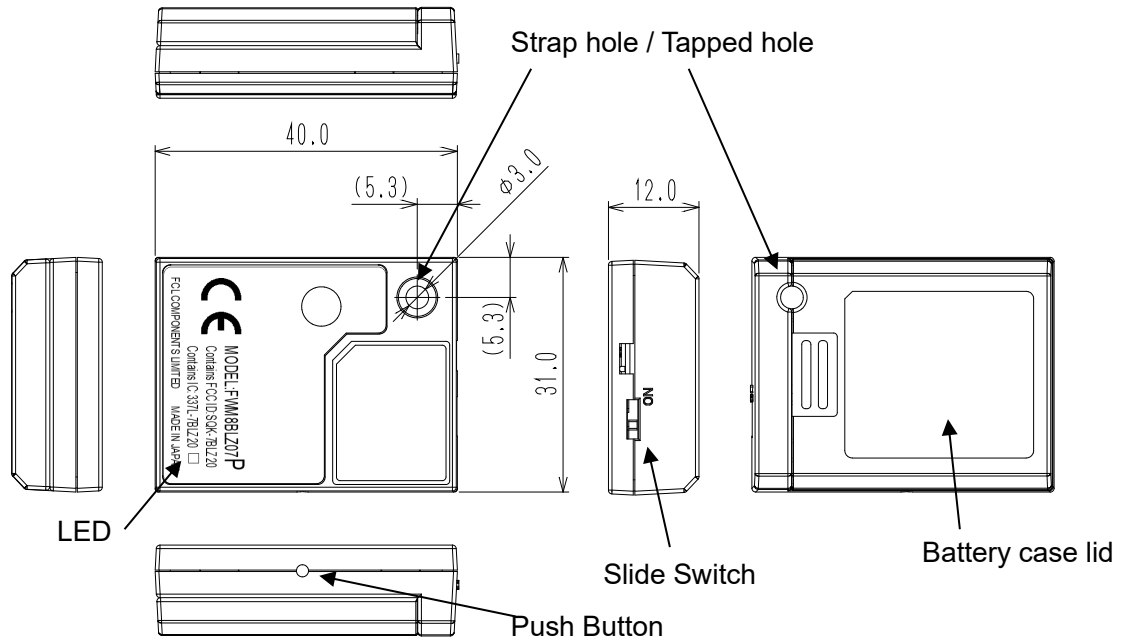

Unit [mm]

9-2. Stamping label specification

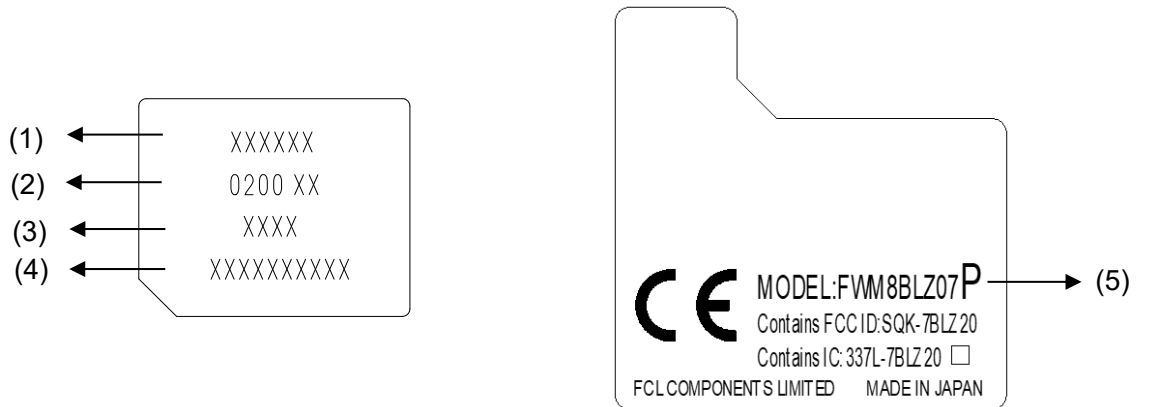

(1) FCL Identification Number: 109114

(2) Lot Number, Version number: 0 2 00 XX

Version: AA~ (Mass Production), Sx (Sample)

Serial number: 00 ~

Month: 1-9, X, Y, Z

Year: Last digit

(3) Role: TAG or ANCHOR

(4) Node address: 10 digit Number (decimal)

(5) FCL Identification Number + Identification symbol: FVM8BLZ07 + P

10. Storage Conditions

- Do not store this product in the environments exposed to shock or vibration. It may result in damage, malfunction, or deterioration of quality.
- Do not throw or drop cartons containing this product during transportation. It may result in damage, malfunction, or deterioration of quality.

11. Warranty period

The warranty period for this product is 18 months after the product is shipped from us.

We can not provide any warranty for the operation of this product in all vibrating condition. Please check in your own environment before use.

12. Mounting / Replacement method of battery

12-1. About using lithium battery 'CR2450'

Please use a battery with a shape of minus electrode convex part height of 0.9 mm or more and a diameter of ϕ 23 mm or less so that clearance (gap) can be obtained between the holder and the battery.

Improper battery shape may damage the beacon holder.

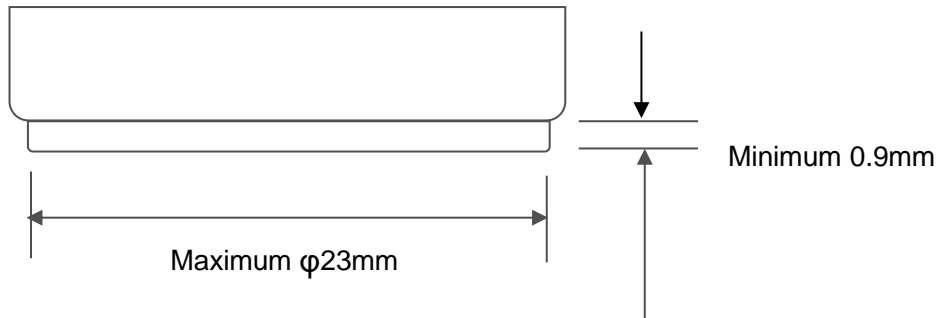

12-2. Removal of a battery cover lid

Slide the battery cover lid in the direction of arrowed line, until the cover is unlocked from claws.

Lift the lid from the tail end and remove.

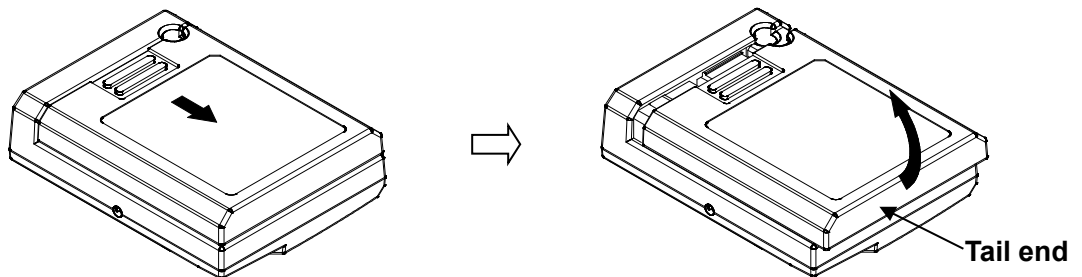

12-3. Mounting of a battery

Insert the battery slantingly in the battery compartment with the (+) sign facing up. While inserting the battery, push it gently.

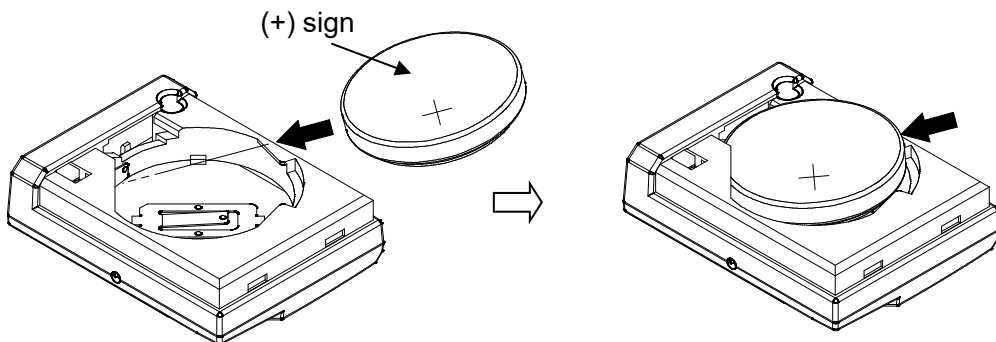

Battery is held firmly by the rib of battery compartment.

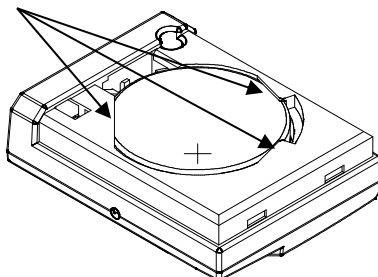

The state when battery is mounted

12-4. Installation of a battery cover lid

Insert the pawls of battery cover lid into the square hole of battery compartment slantingly. Parallel the tail end to battery compartment and push the battery cover lid to lock.

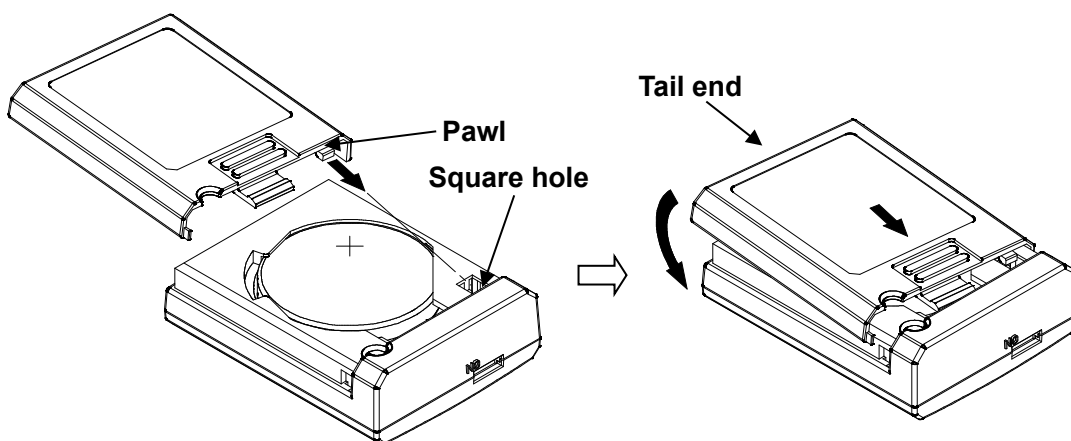

12-5. Replace battery

Remove the battery case lid. (Refer to a procedure of 12-1)

Push the battery gently from the groove by finger(or object such as toothpick) in the direction of arrowed line.

Lift the battery up in the direction of arrowed line, and remove it from the compartment.

Replace with a new battery.

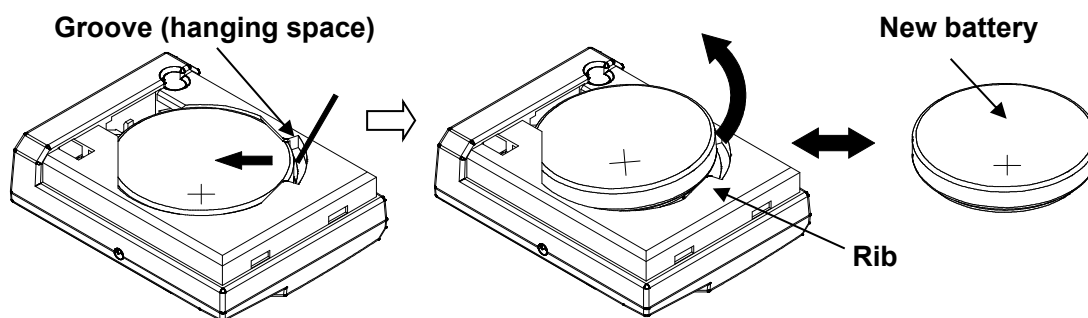

12-6. Precautions for handling batteries

- When transporting products with built-in batteries, follow the regulations of each country and carrier.
 - Remove the battery when disposing of the product.
 - If the battery is not insulated and is randomly mixed and discarded, or if it is discarded together with a conductive material such as a metal piece, it may cause ignition or burst (break).
 - When disposing of the battery, attach an insulating tape to either or both of the (+) and (-) terminals to make it insulated, and then dispose of it as "non-burnable waste" in units of several pieces.
- However, if there are regulations of each local government, please follow those regulations.
- If the battery leaks or smells strange, stop using it immediately and keep it away from fire.

13. Packing Specification in shipment

13-1. Reel label

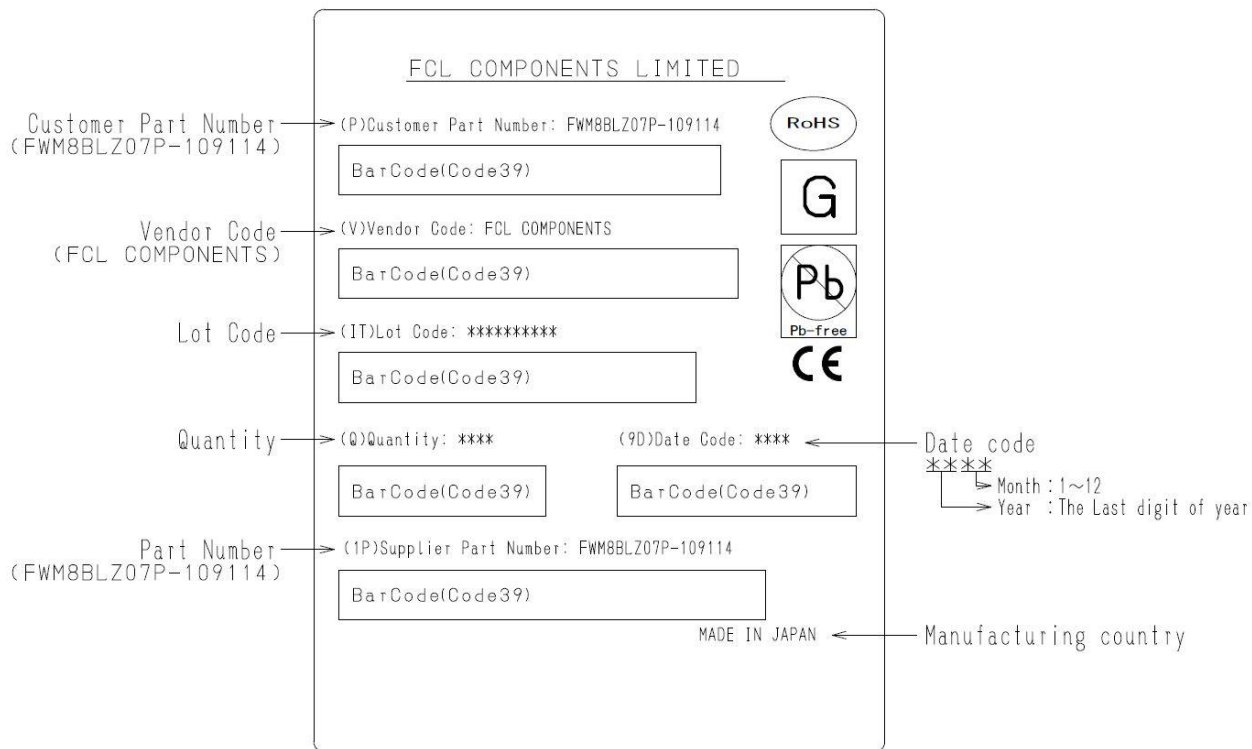

Shipment Packing

13-1-1. Tray packing

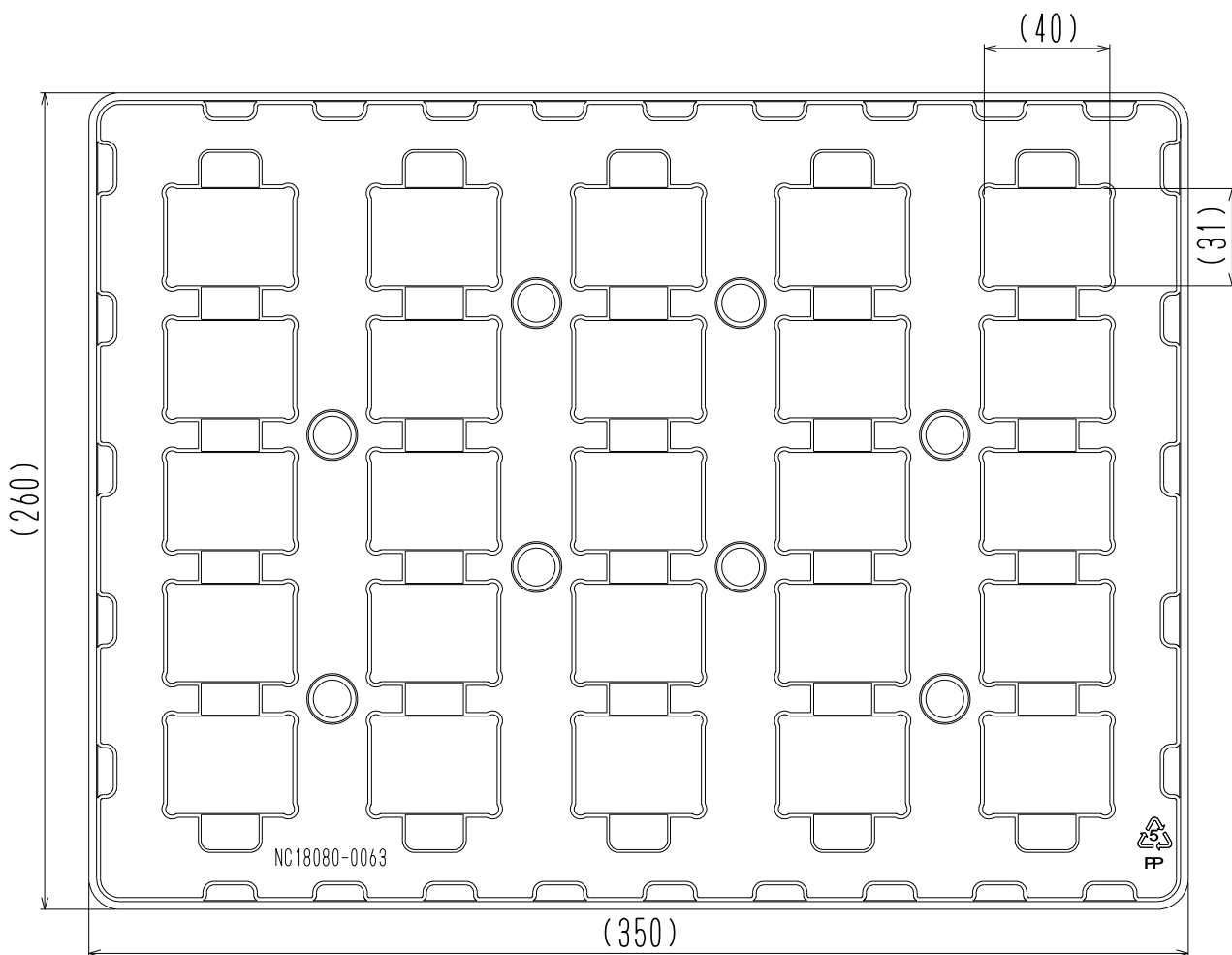

Tray dimensions

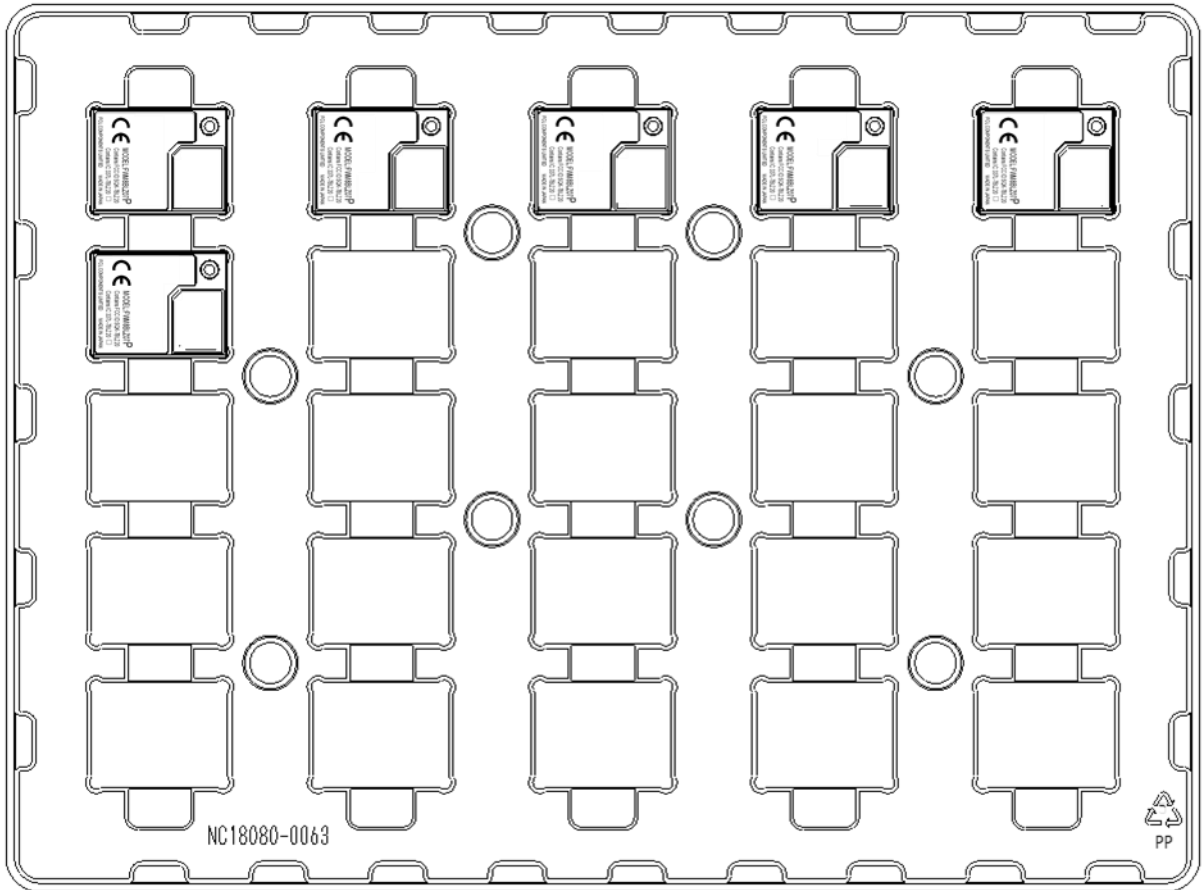

Tray packing

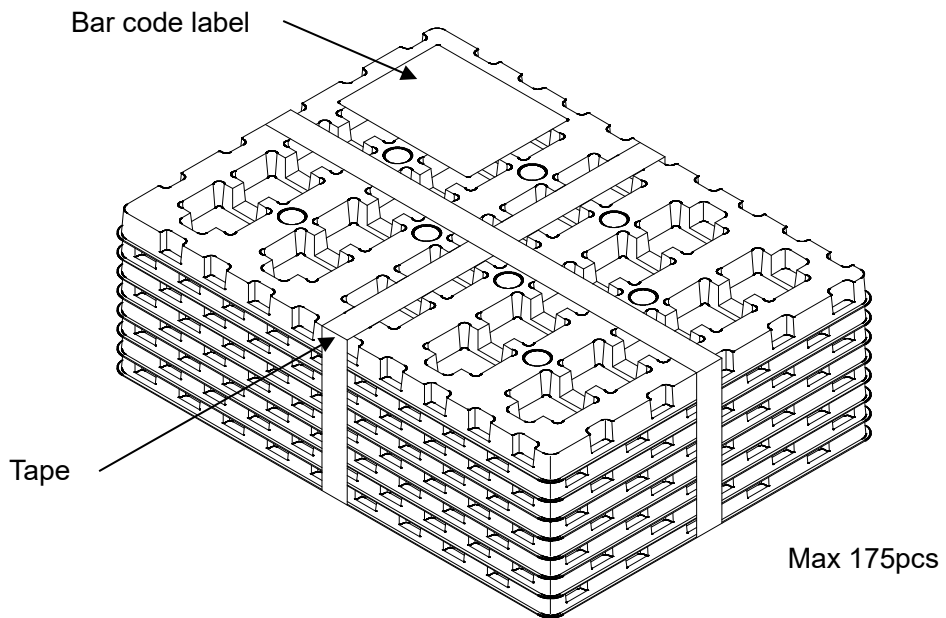

Tray convergence

13-1-2. Shipping package

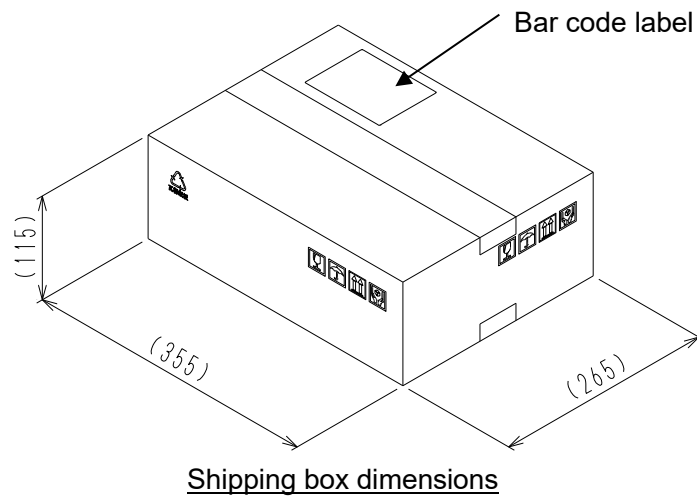
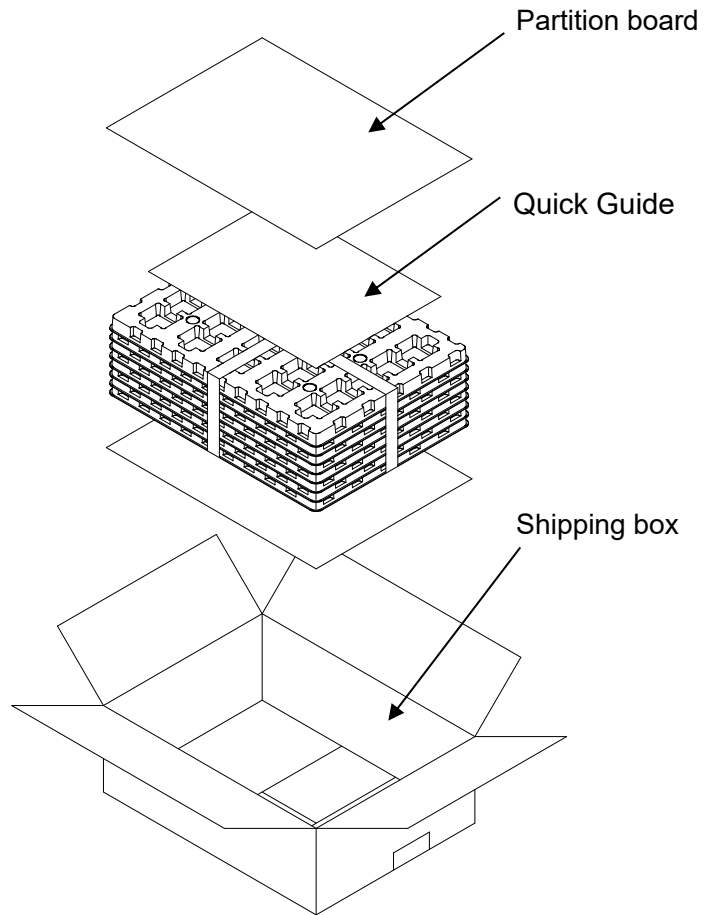

14. Compliance Statement

Note to users in the United States of America

Caution:

Changes or modifications not expressly approved by the party responsible for compliance could void the user's authority to operate the equipment.

Declaration of Conformity

This device complies with part 15 of FCC Rules.

Operation is subject to the following two conditions:

1. This device may not cause harmful interference, and
2. This device must accept any interference received, including interference that may cause undesired operation.

Note to users in the United States of America and Canada

Note to users

It is strictly forbidden to use antenna except designated.

This equipment must not be co-located or operated in conjunction with any other antenna or transmitter.

This equipment complies with FCC/IC radiation exposure limits set forth for an uncontrolled environment and meets the FCC radio frequency (RF) Exposure Guidelines and RSS-102 of the IC radio frequency (RF) Exposure rules. This equipment has very low levels of RF energy that is deemed to comply without testing of specific absorption rate(SAR).

Note to users in Canada

Cet équipement est conforme aux limites d'exposition aux rayonnements énoncées pour un environnement non contrôlé et respecte les règles d'exposition aux fréquences radioélectriques (RF) CNR-102 de l'IC. Cet équipement émet une énergie RF très faible qui est considérée conforme sans évaluation de l'exposition maximale autorisée.

Note to users in Canada

This device complies with Industry Canada's licence-exempt RSSs.

Operation is subject to the following two conditions:

- (1) This device may not cause interference; and
- (2) This device must accept any interference, including interference that may cause undesired operation of the device.

Remarque concernant les utilisateurs au Canada

Le présent appareil est conforme aux CNR d'Industrie Canada applicables aux appareils radio exempts de licence. L'exploitation est autorisée aux deux conditions suivantes :

- (1) l'appareil ne doit pas produire de brouillage, et
- (2) l'utilisateur de l'appareil doit accepter tout brouillage radioélectrique subi, même si le brouillage est susceptible d'en compromettre le fonctionnement.

European Community Compliance Statement

Note:

Hereby, FCL Components Limited, declares that this FWM8BLZ07 is in compliance with the essential requirements and other relevant provisions of Directive 2014/53/EU.

The full text of the EU declaration of conformity is available at the following internet address:

<https://www.fcl-components.com/products/wireless-modules/information/red.html>



15. Caution about Firmware installed

We may update the firmware without prior notification.

16. Version History

Version	Contents change	Date
1	Created first edition.	April 2, 2021
1.1	Change term: "Wirepas Mesh" to "Wirepas Massive" 13-1. Reel label: CE mark is added. 13-2-2. Quick Guide is added. 14. Compliance Statement is added.	May 31, 2022
2	Change of Company name	Feb 1, 2024